

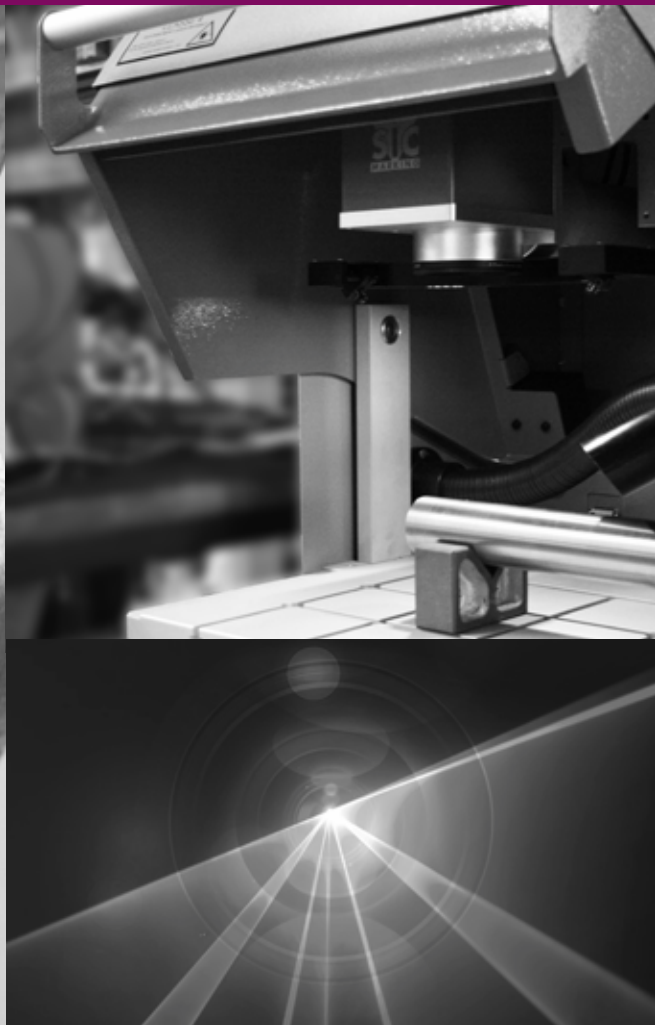

FIBER LASER RANGE



sic-marking.com

WHO ARE WE?

We are the global expert in marking and traceability solutions.

SIC Marking is **an international company** developing innovative permanent marking solutions and automated identification for the complete traceability of industrial components.

For over 30 years, SIC Marking has engineered a full range of technically superior marking machines in dot peen, scribing and laser technologies for a wide range of materials such as steel, alloys, stainless steel, titanium, aluminum, and plastics.

Today we work with professionals in various industries such as: automotive, aerospace, metallurgy, Oil & Gas & Offshore, mechanical engineering, plastics processing, railway, medical, construction, defense...

With an **experienced, responsive and involved team**, SIC Marking offers a complete range of standard products, and custom machines to meet all your needs.



300 Employees



50 Million € Turnover



15% Annual growth



Installed base of 40 000 machines worldwide



More than 50 000 customers



Large Patents Portfolio



10 new products in the last three years



10% of the Turnover invested in R&D



AT YOUR SERVICE

SUPPORTING YOU ALL OVER THE WORLD

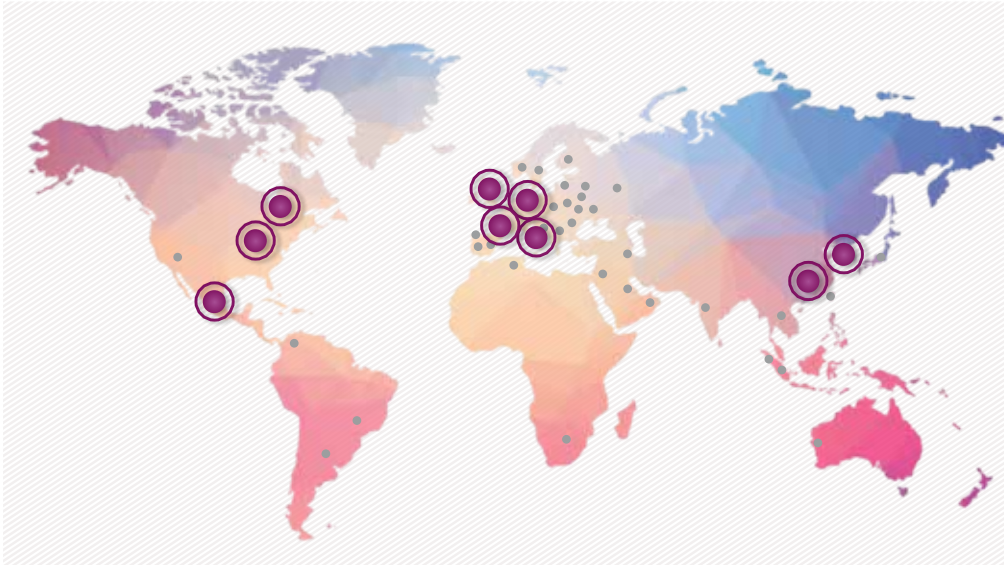

Locations in Germany, Italy, the UK, Canada, USA, Mexico, China, South Korea and a network of over 40 distributors...

OUR CENTRES OF EXCELLENCE

We spend around 10% per year of turnover in R&D to develop new products in order to make our customers more competitive. Today SIC Marking offers the widest and most up to date range of products which runs from standard products to custom solutions.

We have a dedicated supply chain for our **custom solutions including a laboratory, design office, production workshop and a project management team.** This enables us to define both the best technical

solutions for our customers specific needs and to ensure a precise project follow-up for a smooth, quality on-time delivery.

We have more than 100 trained technicians around the world ready to support our customers during the entire product and/or solution life cycle: from commissioning and training to maintenance, supply of spare parts, repairs, upgrades and telephone helpline.



OUR TECHNOLOGICAL APPROACH

«Quality, performance and innovation.»
reflects SIC Marking's philosophy.



THE FIBER LASER



Aesthetic



Endurance



Speed



No maintenance

To meet the ISO quality requirements, traceability is essential. This is the reason why laser marking is used by manufacturers to automate marking operations and thus **guarantee 100% control of their processes.**

This laser marking technology consists of **releasing radiation from a source** which is then amplified through an optical fiber and directed through a galvanometric head toward the part to be marked. The beam focused on the material by a lens creates a marking chemical reaction.



Ytterbium doped
SIC Marking
fiber source.

This technology is mainly used for permanent marking **on all types of materials**, from plastic to metal parts, irrespective of their hardness or surface finish. The laser is recommended for **high speeds and high quality markings.**

The advantages of a fiber source:

kW

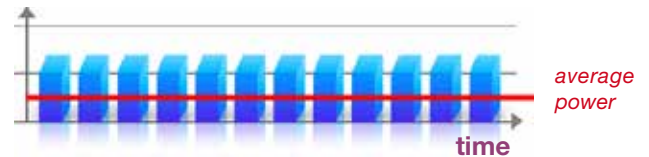

- Marking at reduced peak power
- High frequency
- Marking does not distort the material
- Variable pulse duration

kW

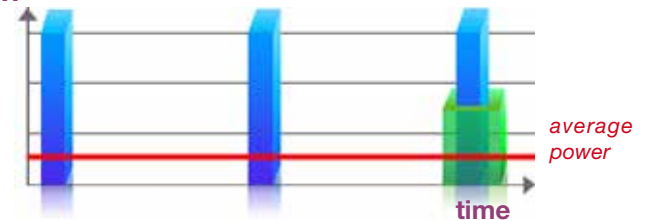

- Marking at high peak power
- Low Frequency
- Strong interaction with the material
- Variable pulse duration

MARKING METHODS

Surface condition respected (annealing)



Powerful marking with oxidation (foaming)



Removing layers

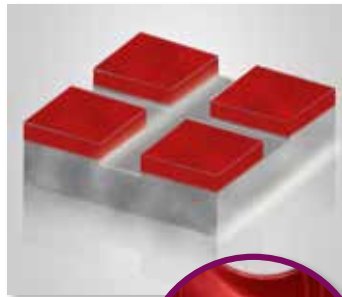

Removing material (engraving)



TYPES OF MARKING



SIC

Single line



SIC

Double line



SIC

Hatched

TYPES OF SURFACES



Flat marking



> Radiant



> Straight



Marking on circumference



Curved marking

OUR CONTROL UNIT

FIBER UNIT

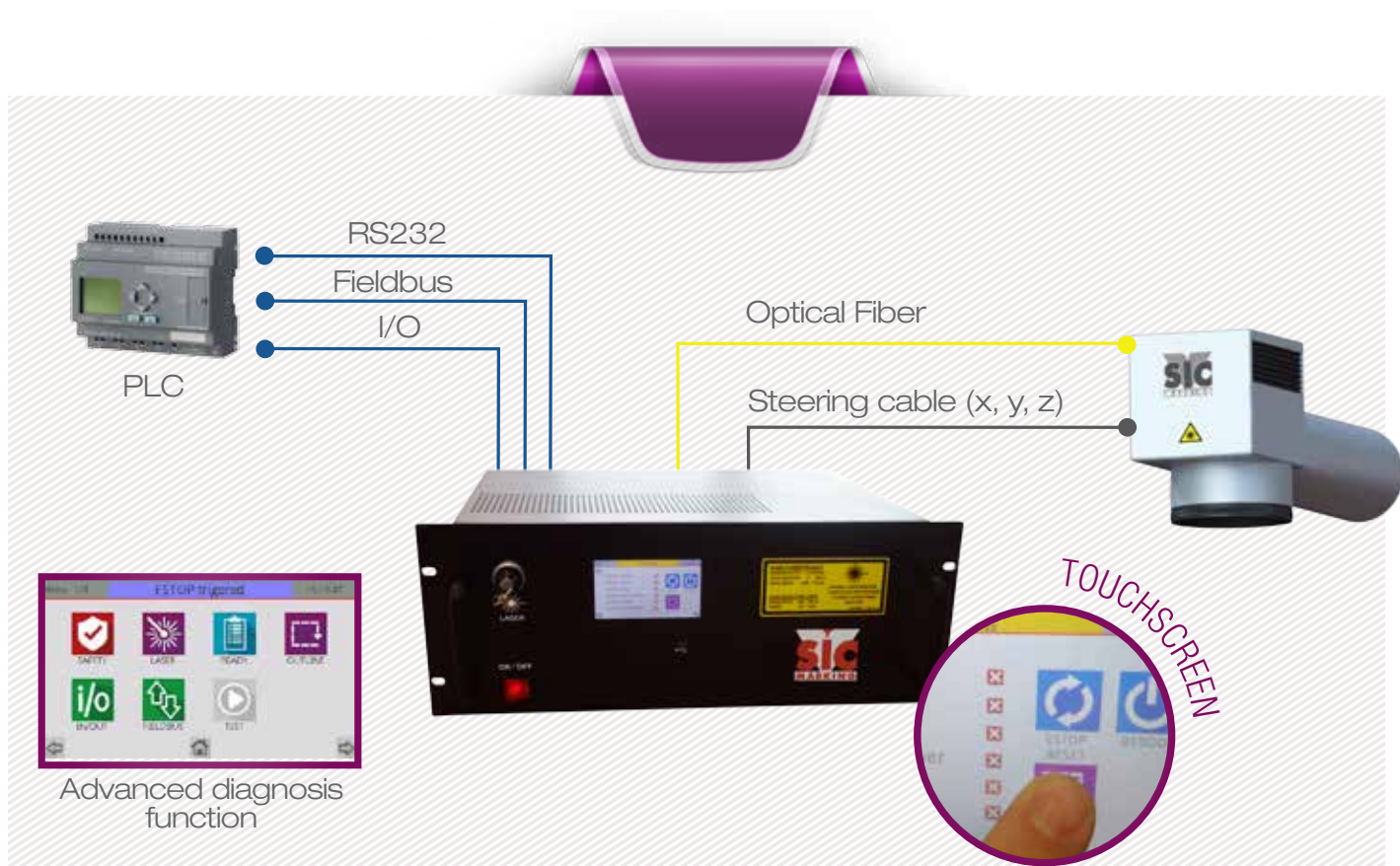

+ TECHNOLOGY & DESIGN

- Operating method: pulsed (variable frequency)
- Consumption: 750 W
- Wavelength: 1 064 nm
- Digital axis control (linear and rotary)
- Ultra Compact: 4U height (177mm)

+ RELIABILITY AND PERFORMANCE

- Long-life components ($\geq 100\ 000$ h)
- Self diagnostic function
- Cooling: by air only
- Warranty: 2 years (5 years optional)

+ COMMUNICATION CARDS

(optional)



+ OPERATING

- Laser driven by «SIC LASER» software
- USB interface, Windows environment
- User-friendly interface with icons navigation

SECURITY

■ The NF-EN 60825 standard



The NF EN 60825-1 / A2 standard for the safety of laser products provides information on the classification of lasers for security, laser safety calculations, risk control measures, recommendations for laser safety managers

and for corporate hygiene and security committees. **For laser products manufacturers, the standard provides a reference for the compliance of installations. All laser products sold by SIC Marking meet this standard.**



■ Integrated security

- Unit certified by a specialised organisation
- Emergency stop
- Laser safety enclosure

■ Marking workstation

- Class 1 machines
- CE certified equipment

■ Integrated laser

- Class 4 laser
- For an integration on a production line with adapted security rules

COMMUNICATION

SIC Marking systems can be connected to industrial networks without any additional equipment.

Already equipped with full connectivity (digital I/O, Ethernet TCP/IP, RS232...), our systems also offer many features to interact with all the elements that set up their environment. **Our machines can be easily integrated on all production lines using Profinet, Profibus and Ethernet/IP.**

Direct connection to the industrial network without use of a gateway provides considerable time savings. It also reduces the cost of machinery installation, of engineering and of commissioning.

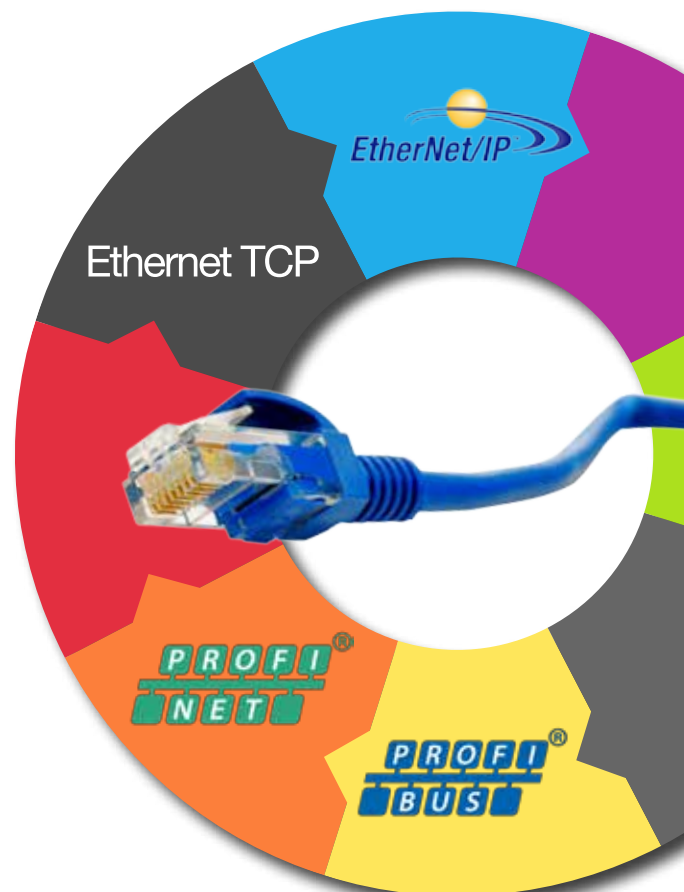

OUR INTEGRATED LASERS

i104
Easy
LG
HD

OUR I104 RANGE

Our integrated laser systems have been engineered for intensive use in any industrial working environment. They can be integrated into production lines or used as a stand-alone marking station. They are suited for both low and high rates of production, and can be fully customized with additional features and tools. Resizing the housing, manufacturing dedicated tooling systems, or adding extra axes (e.g. Z and rotary) can be made on request.

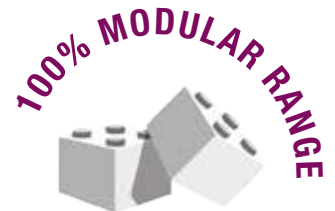

• Available configurations:

Easy 20-30W

Excellent value for money
Marking on all types of materials and difficult surface conditions



LG 50W

Deep marking
Ultra fast marking



HD 20W

Multi material (ideal for aluminums and plastics...)
Reduced cycle time



+ GREAT VALUE FOR MONEY

- SIC Marking fiber laser
- Proven technology
- Multi applications (metals, plastics...)

+ VERSATILITY

- Marking on all types of materials and difficult surface conditions
- Surface or hollow marking
- 1D or 2D codes (Data Matrix) marking
- Images or vector logos marking
- Decorative marking

+ EASE OF USE AND INTEGRATION

- Small size
- Built-in communication cards and memory
- No PC required to operate on the line
- Adjustable pulse duration per object (for HD configuration)

+ ROBUSTNESS AND RELIABILITY

- Long-life components ($\geq 100\ 000$ h)
- Suitable for intensive use in industrial environments
- Reduced maintenance
- 2 years warranty

GALVANOMETRIC HEAD

The laser beam passes through the collimator, to be directed to two oscillating mirrors. Each of these mirrors is an axis of the marking field. At the head's exit, the focusing lens concentrates the power in a single point.

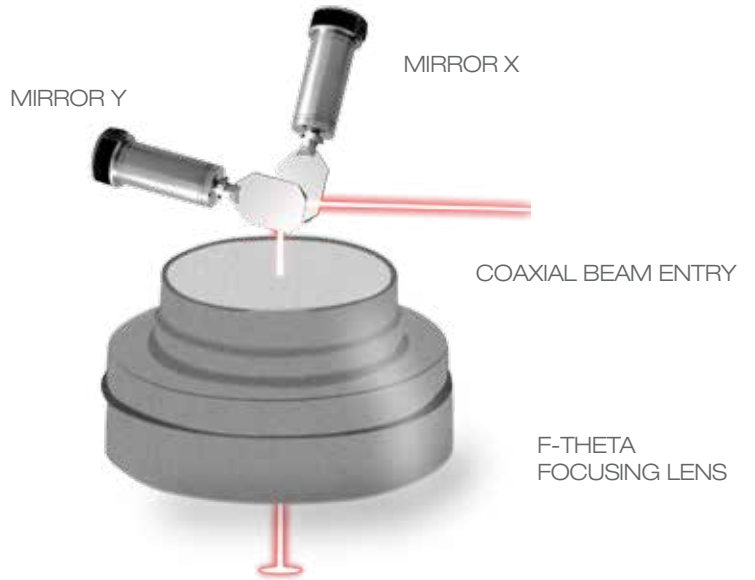

•Mechanical features:

| i104 | |
|---------------------------------------|---|
| Marking window | <input type="checkbox"/> 60 mm <input type="checkbox"/> 100 mm <input type="checkbox"/> 170 mm (others consult us) |
| Weight | 5kg |
| Consumption | 750W |
| Security | Class 4 Laser (EN60825-1 standard) to secure |
| Software | SIC Laser software |
| Pulse duration (for HD configuration) | from 2 ns to 200 ns |

•Programming mode:

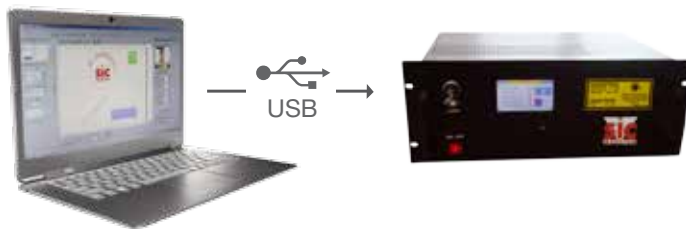

- Creation of entities to be marked: characters, logos, 1D or 2D
- Font choice «True Type»
- Pen setups

•Production mode:



OUR MARKING WORKSTATIONS

L-Box
XL-Box

OUR LASER WORKSTATION RANGE

SIC Marking's powerfully precise laser technology is the secret behind our laser marking workstations. They can be integrated directly into production lines, or operated as stand-alone, autonomous workstations. Resizing the housing, manufacturing dedicated tooling systems, or adding extra axes (e.g. Z and rotary) can be made on request.

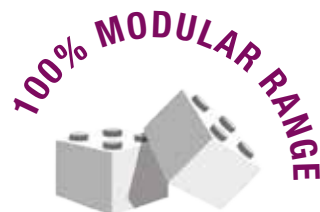

• Available configurations:

Easy 20-30W

Excellent value for money
Marking on all types of materials and difficult surface conditions



LG 50W

Deep marking
Ultra fast marking



HD 20W

Multi material (ideal for aluminums and plastics...)
Reduced cycle time



+ ROBUSTNESS AND RELIABILITY

- Long-life components ($\geq 100\ 000$ h)
- Reduced maintenance
- 2 years warranty (5 years optional)

+ FIBER LASER

- SIC Marking Fiber laser sources doped with Ytterbium
- Technologie éprouvée
- 1D or 2D codes (Data Matrix) marking
- Fast and high quality marking

+ USER-FRIENDLY

- Ergonomic door: soft opening
- Access the marking zone from 3 sides
- Large viewing window
- Reduced width for improved ease of use
- Automatic door system & Motorized Z axis

+ SECURITY

- Class 1 security laser (EN 60825-1 standard)

+ ROBOT MODE (XL-Box)

- Laser fully controllable by automated robot cell



•Caractéristiques techniques mécaniques :

| | L-Box | XL-Box |
|-----------------------------|--|---|
| Marking window | ☐ 100 mm ☐ 170 mm (others consult us) | |
| External dimensions | 505 x 770 x 765 mm | 655 x 755 x 995 mm |
| Marked parts Dimensions | Max height: 223 mm - Max length: 440 mm | Max height: 370 mm - Max length: 570 mm |
| Lighting | LEDs on the work area | |
| Working distance adjustment | Manual or motorized column with counter and laser pointers | |
| Security | Class 1 security laser (EN 60825-1 standard) | |

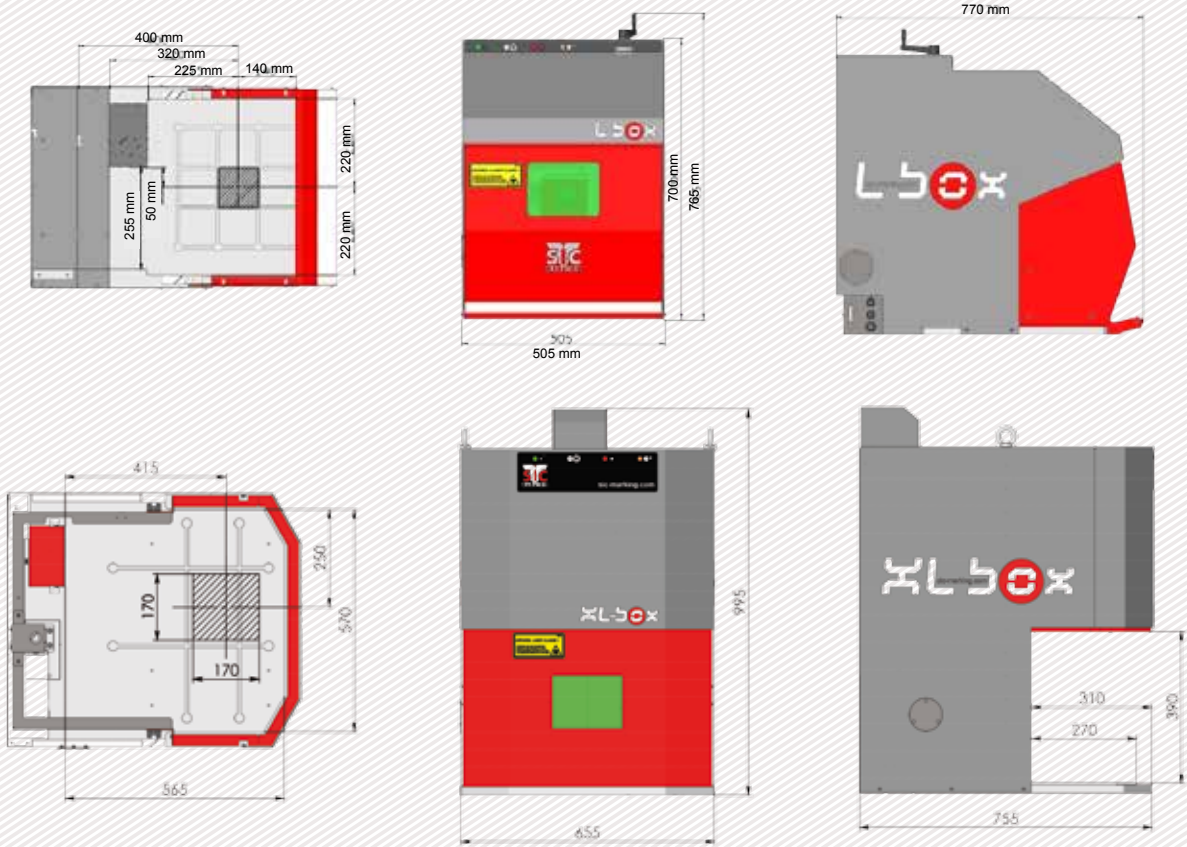

«SIC LASER» SOFTWARE

| | |
|-------------------|---|
| Function | Creation and marking file editing (drawing, text, bar code, Data Matrix code ...) |
| Laser settings | Defining multiple pens (speed, power, frequency ...) |
| Fonts | All TrueType fonts for PC |
| Encryption | 1D Barcode and 2D codes (Datamatrix) |
| Image | Import of image files (.bmp, .jpg) |
| Logo/Illustration | Import of vector files (.plt, .dxf, .ai) |
| Data base | Link with external files (txt, xls) |
| Cylindrical parts | Marking function of rotary axis |

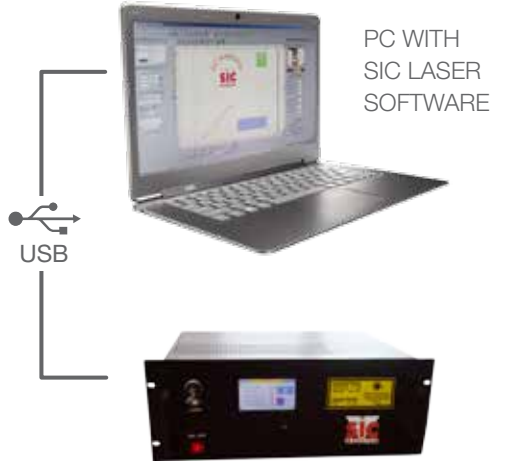

OPTIONS

i104 L-Box XL-Box

3D MARKING FUNCTION

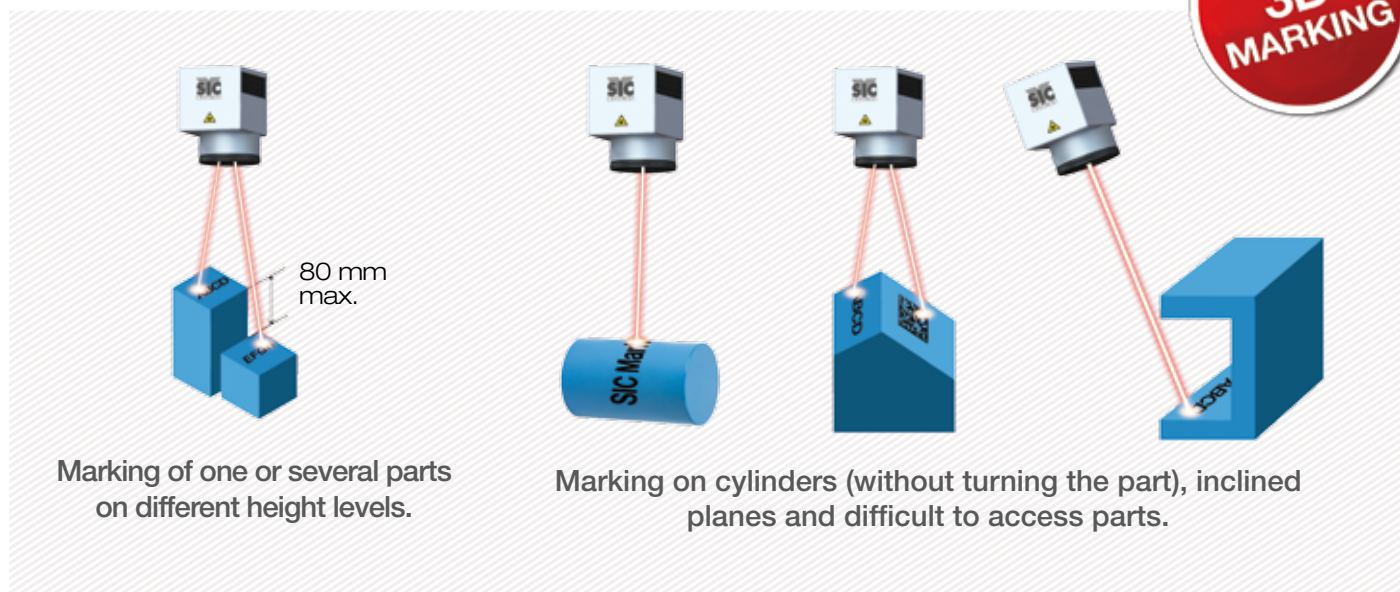

INTEGRATED VISION SYSTEM

SIC Marking's identification systems allow the reading of all types of characters (1D, 2D codes and alphanumeric characters). With its unique expertise, SIC Marking ensures a full service of marking / reading systems. SIC Marking is also developing marking analysis softwares and softwares to backup data (historical, image, reading report...).

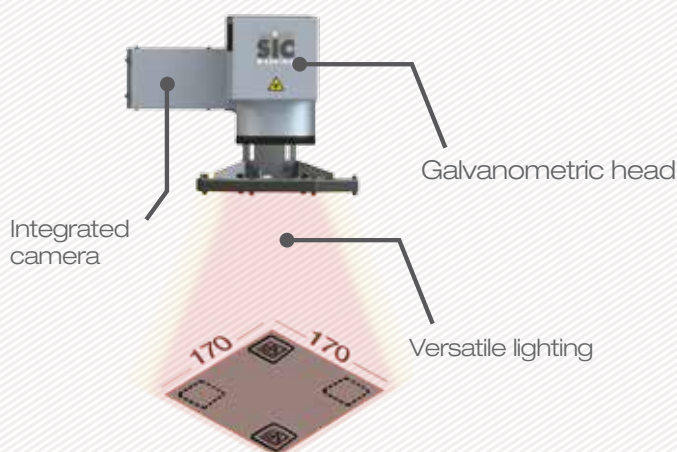

Reading & grading of several 2D codes (QR-Code, Datamatrix) in a large marking window (170 x 170). Reading possible in the entire marking window.



ACCESSOIRES

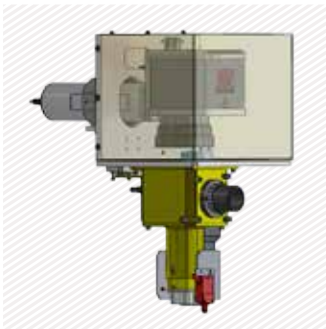

Protective sleeve



Extraction and filtration systems



Custom enclosure

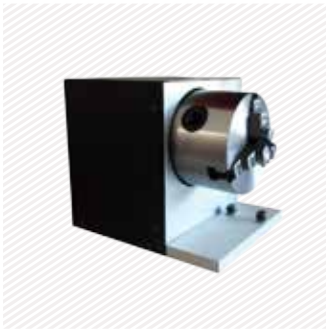

Divider axis



Motorized Z axis



Full Chassis



Part loading drawer



Lateral extension



Manual rotating platter

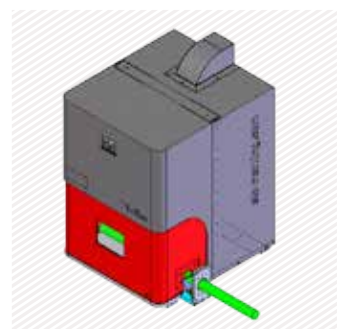

Long part marking

OUR CUSTOM APPLICATIONS

COMPLETE TURNKEY WORKSTATIONS

With an experienced, responsive and dedicated team, SIC Marking designs customized, turnkey solutions for all industrial sectors. Our design office produces machines in compliance with your specifications and your industrial standards.

We make changes to our standard workstations (resizing, adding movements...) or create specific systems to meet your specifications.

CUSTOM INTEGRATIONS

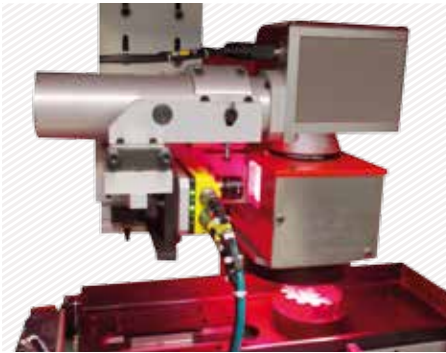

Laser station equipped with a loading drawer and a dedicated reading system



Protective sleeve for laser



i104 laser with a protective sleeve for manual marking of steel plates.

AUTOMATIC NAMEPLATES CHARGERS

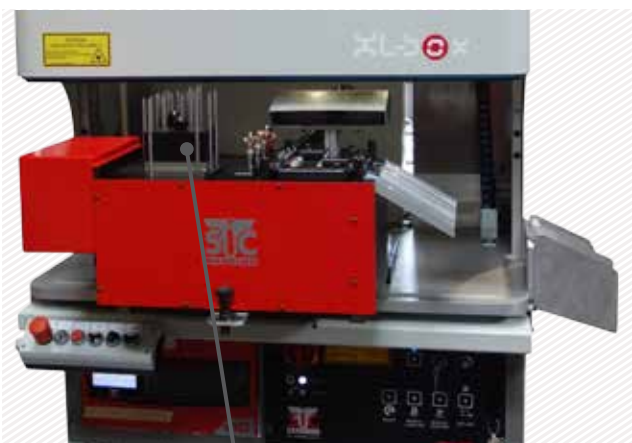

Loading area for blank plates



Stacking tub for plates



Automatic stacker

MARKING AND READING



XL-Box marking station with deported reading system

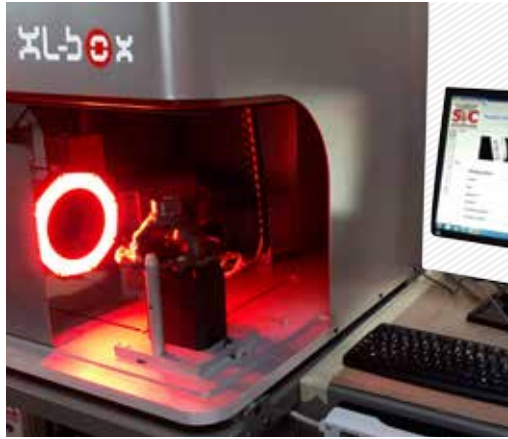

XL-Box laser machine with integrated vision in the marking head



CUSTOM WORKSTATIONS



Laser station equipped with a turntable

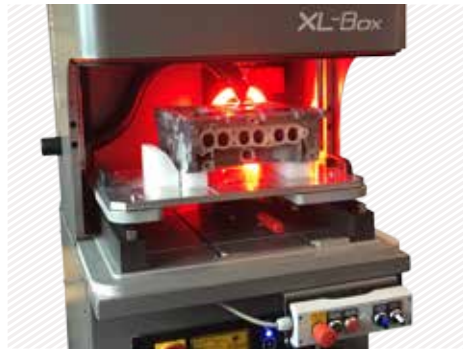

XL-Box laser station with custom tooling



4-axis laser marking system



XL-Box laser station integrated in robotic cells



Laser station for large dimension parts



Laser station for marking three carbon brake discs inside and outside

DIFFERENT TYPES OF MARKS

Steel



Deep marking on steel



High speed steel



Treated steel

Plastics



Aluminum



Cast aluminium



Painted aluminium



Anodized aluminium

Various



On metal sheet



On ceramic



On carbide



On rubber



On a painted part

OUR TEST LABORATORY



Free tests



Marking and reading feasibility studies

OTHER TECHNOLOGIES

DOT PEEN



Our dot peen technology is well-known and approved, it has allowed SIC Marking group to become a world leader in industrial marking.

This type of marking is made by repeated indented into the material. The force is transmitted by a controlled electric pulse through a coil, which powers the magnetic assembly and its stylus towards the surface.

We offer a complete dot peen range with portable, column mounted or integrated systems.



• Portable Range



• Column mounted Range



• Integrated Range

SCRIBING



This technology is required mainly in applications where the noise level in the working environment is an issue. Scribing ensures a quiet and permanent marking of high quality, ideal for example

for OCR reading applications (Optical Character Recognition).

Our integrated marking machines are designed to be placed at the heart of the production lines and can also be adapted to specific needs, such as VIN marking (Vehicle Identification Number).

«More than 10000 customers trust us



in many different industries»



Aluminium, Nippon, Musashi, Mitsubishi, Montupet, NTN, NSK, Oxford, Pratt&Whitney, Press & Piat, Press Kogyo, Puchov, Puch, Robotics, Renault, Rexroth, Richard Urbanek, Sachs, Saeron, Safe Bag, Scana, Safran, Saic Mo, Snecma, Seojin, Schneider, Schlumberger, Shinwa S, Sicta, Siemens, Smart, SNOP, Sogefi, Sona Somic L, Stackpole, Steiber, Taiway, Taiyiu Warner, Takarazuka, Taoyan Plant, Tapei, TechJet Aerofoils, Tata, Thai Sur, Built Buses, Teneco, Techspace Aero, Ten, Transcar, Transeje, Transmotor, Transpart, Traxle, Truck, &M, Vachette, Valinox, Valeo, Vallourec, Valti, Valtimet, VAM, Vehcom, Veltri, Vent, us, Volkswagen, Volvo, Warner, Webasto, Wichita, Williams, W, s, Airbus, AKS, Albarus, Alcan, Alstom, Am, ASK, Aubert&Duval, Audi, A, Brewer Bell





SIC Marking France

195 Rue des Vergers
69480 Pommiers
France
Tel : +33 472 54 80 00
Fax : +33 478 47 39 40
info@sic-marking.com

sic-marking.com

SIC Marking Italy

Via Collamarini 9
40138 Bologna
Italy
Tel : +39 (0) 51 6027811

SIC Marking Limited

B1 Harris Road,
Wedgnock Industrial Estate,
Warwick, CV34 5JU
England
Tel : +44 (0) 1926 830372

SIC Marking USA

137 Delta Drive
Pittsburgh, PA 15238
USA
Tel : 1 (877) 742-9133

SIC Marking China

No. 601, No. 4 Building, No. 258
Jinzang Rd. Shanghai
Shanghai 201206
China
Tel : +86 (0) 21 6164 5600

SIC Marking GmbH

Am Bruch 21 - 23
42857 Remscheid
Germany
Tel : +49 (0) 2191 46240-0

SIC Marking Mexico

Canada #129
Parque Industrial Unidad Nacional
Santa Catarina, N.L CP 66350
Mexico
Tel : +52 (81) 8676 3383

SIC Marking Canada

35-2, rue De Lauzon
Boucherville Qc J4B 1E7
Canada
Tel : 1 (888) 661-9133

SIC Marking South Korea

Office # 707, Banpo Technopia,
186, Galmachi-ro, Jungwon-gu,
13230 Seongnam-si, Gyeonggi-do,
South Korea
Tel: 031-731-8400