



ENG



TR



D



ES



FR



AR

PACKAGING SOLUTIONS



SUMTEKNIK

MAKİNE SANAYİ VE DIŞ TİC. LTD. ŞTİ.

Your Partner for all Industrial Engineering and Packaging Solutions...

ABOUT US



As Sum Teknik® Makine Sanayi ve DıŐ Ticaret Ltd. Őti; we are producing all types of packaging equipments and machines with over 15 years of experience and know-how in the industry. Both for local and foreign markets; we are in the service of manufacturers looking for alternative solutions by offering standard equipments or design engineering services for packaging lines.

Technical packaging line expertise,
Flexible industrial packaging and packaging systems,
If you need any support on operational efficiency oriented ideas;

By distinguishing you from others,
Reducing packaging costs,
Increasing shelf life quality for packed products,
We can create a road map for the selection of professional equipment that meets your target for 100% packaging standards.

Our company, which keeps on its way with self confidence in the machinery sector; aims to continue with its customers; by growing together with the customer's understanding of service that doesnot compromise customer satisfaction.

Your Partner for all Industrial Engineering and Packaging Solutions...

- ✓ Case sealing from the top and bottom automatically
- ✓ Manual adjustment for different case sizes
- ✓ Case dimensions: (min / max)
 - L : 150 - ∞ mm
 - W: 120 - 500 mm
 - H : 120 - 500 mm
- ✓ Length of infeed and outfeed conveyor: 450 mm
- ✓ Side drive belts
- ✓ Capacity: Max 22 case/minute
- ✓ Power: V 380 ±%10 50/60 Hz
- ✓ Tape width: 5 cm-2" (Opt. 7 cm-3")
- ✓ Tape length: Max 1000 mt
- ✓ Strong structure suitable for 24 hour usage
- ✓ Schneider brand components
- ✓ 2 motors (Optional as 3 motors)
- ✓ Installed power: 0,36 kwh
- ✓ Movable braked wheels
- ✓ Protection class IP 55
- ✓ Colour: RAL 7040 - 5002
- ✓ CE certification
- ✓ Made in Turkey

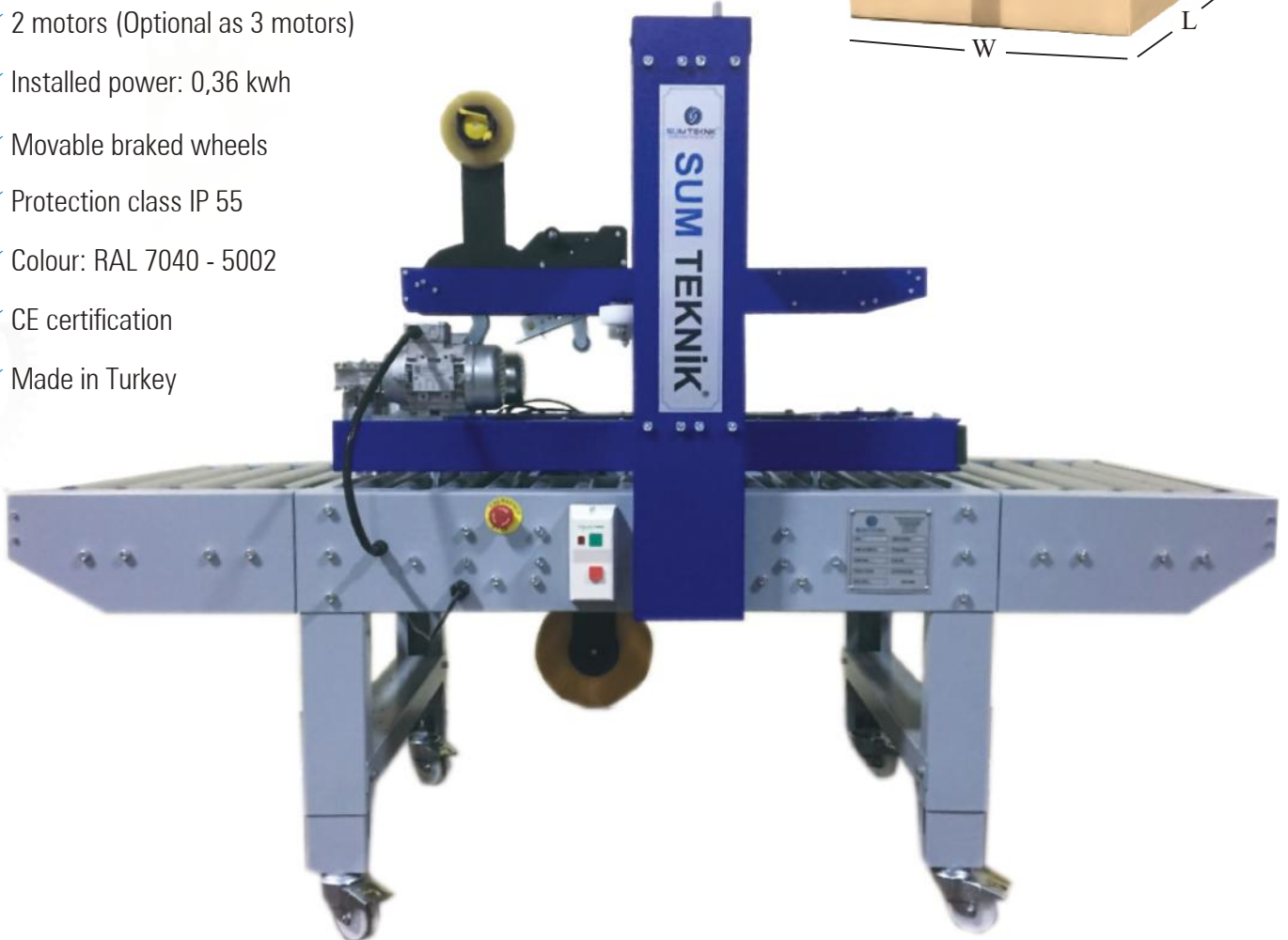
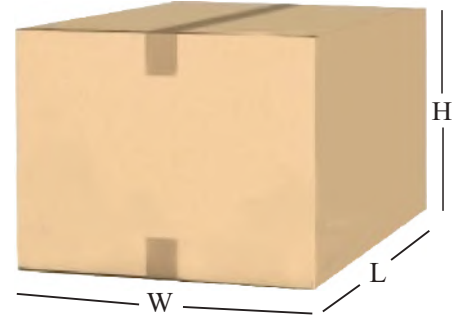

KEKB-SEMI AUTOMATIC CASE SEALER MIX SIZE

- ✓ Safety plexi glass doors
- ✓ Machine that adjust itself automatically according to different box sizes
- ✓ Case dimensions: (min / max)
 - L : 150 - ∞ mm
 - W : 120 - 500 mm
 - H : 120 - 500 mm
- ✓ Length of infeed and outfeed conveyor: 450 mm
- ✓ Side drive belts
- ✓ Capacity: Max 12 case/minute
- ✓ Power: V 220 ±%10 50/60 Hz
- ✓ Tape width: 5 cm-2" (Opt. 7 cm-3")
- ✓ Tape length: Max 1000 mt
- ✓ Strong structure suitable for 24 hour usage
- ✓ 2 motors (Optional as 3 motors)
- ✓ Installed power: 0,36 kwh
- ✓ Movable braked wheels
- ✓ Protection class IP 55
- ✓ Colour: RAL 7040 - 5002
- ✓ CE certification
- ✓ Made in Turkey
- * Requested air pressure:
5 - 6 bar

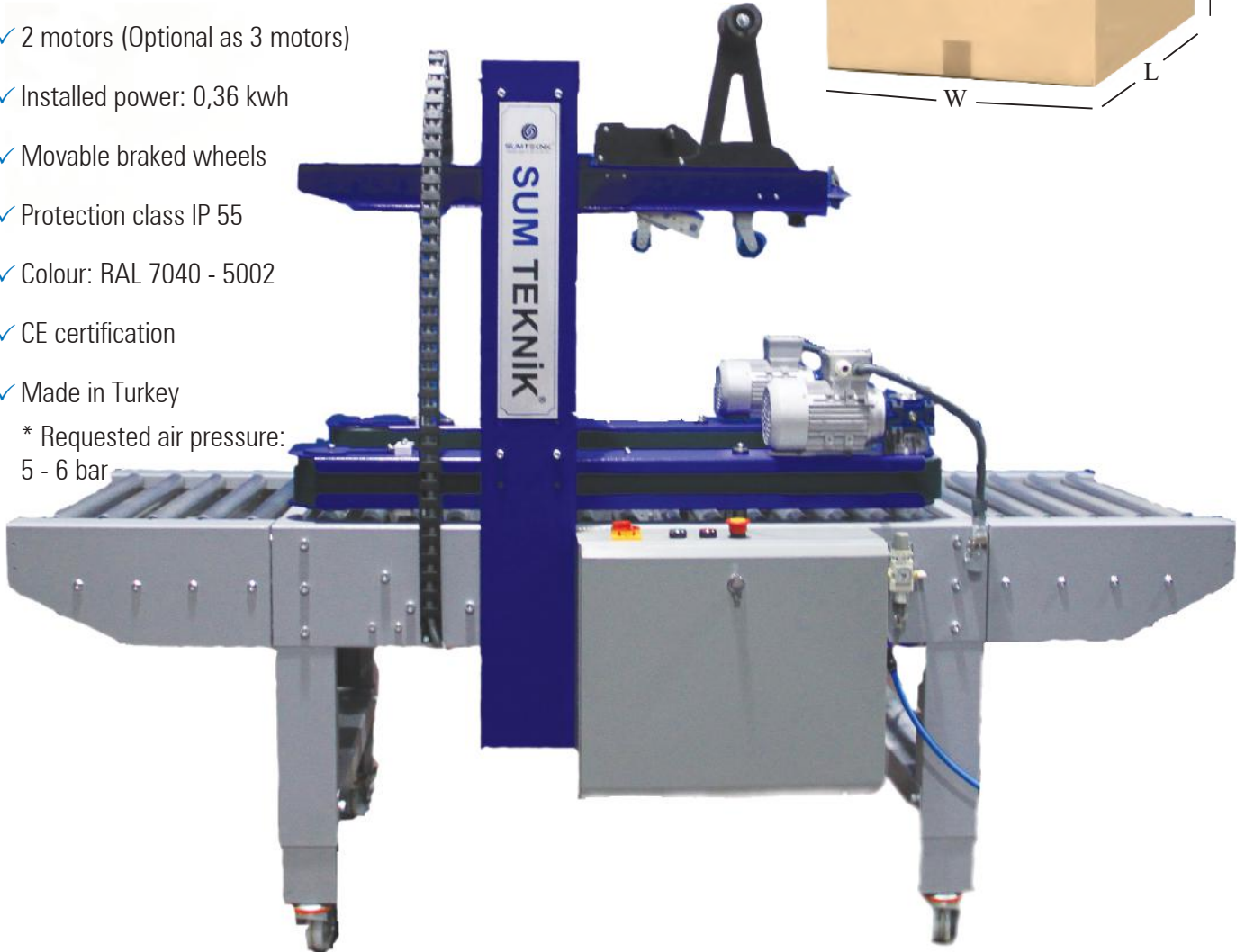
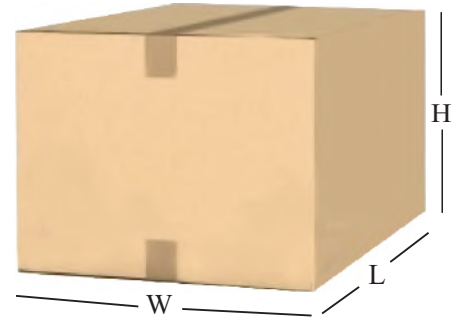
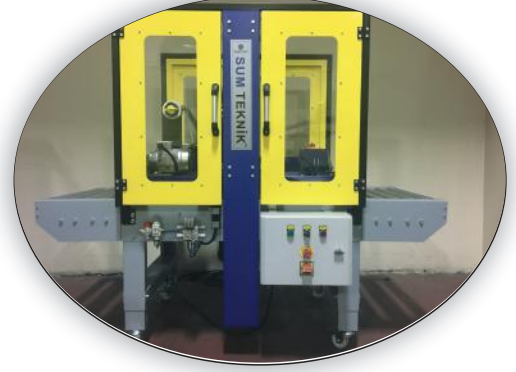

OTKB-TOP FLAP CLOSING CASE SEALER

- ✓ Automatic flap closing machine
- ✓ Case dimensions: (min / max)
 - L : 200 - 600 mm
 - W: 120 - 500 mm
 - H : 120 - 550 mm
- ✓ Manual adjustment for different case sizes
- ✓ Length of infeed and outfeed conveyor 450 mm
- ✓ Top and bottom taping unit
- ✓ Side drive belts
- ✓ Capacity: Max 22 case/minute
- ✓ Power: V 380 \pm %10 50/60Hz
- ✓ Power consumption: 0,36 kWh
- ✓ Tape width: 5 cm-2" (Opt. 7 cm-3")
- ✓ Tape length: Max 1000 mt
- ✓ Machine dimensions: (LxWxH)
1850 x 900 x 1500 mm
- ✓ SMC Pneumatic
- ✓ Security cover
- ✓ Movable braked wheels
- ✓ CE certification
- ✓ Made in Turkey

* Requested air pressure: 5 - 6 bar

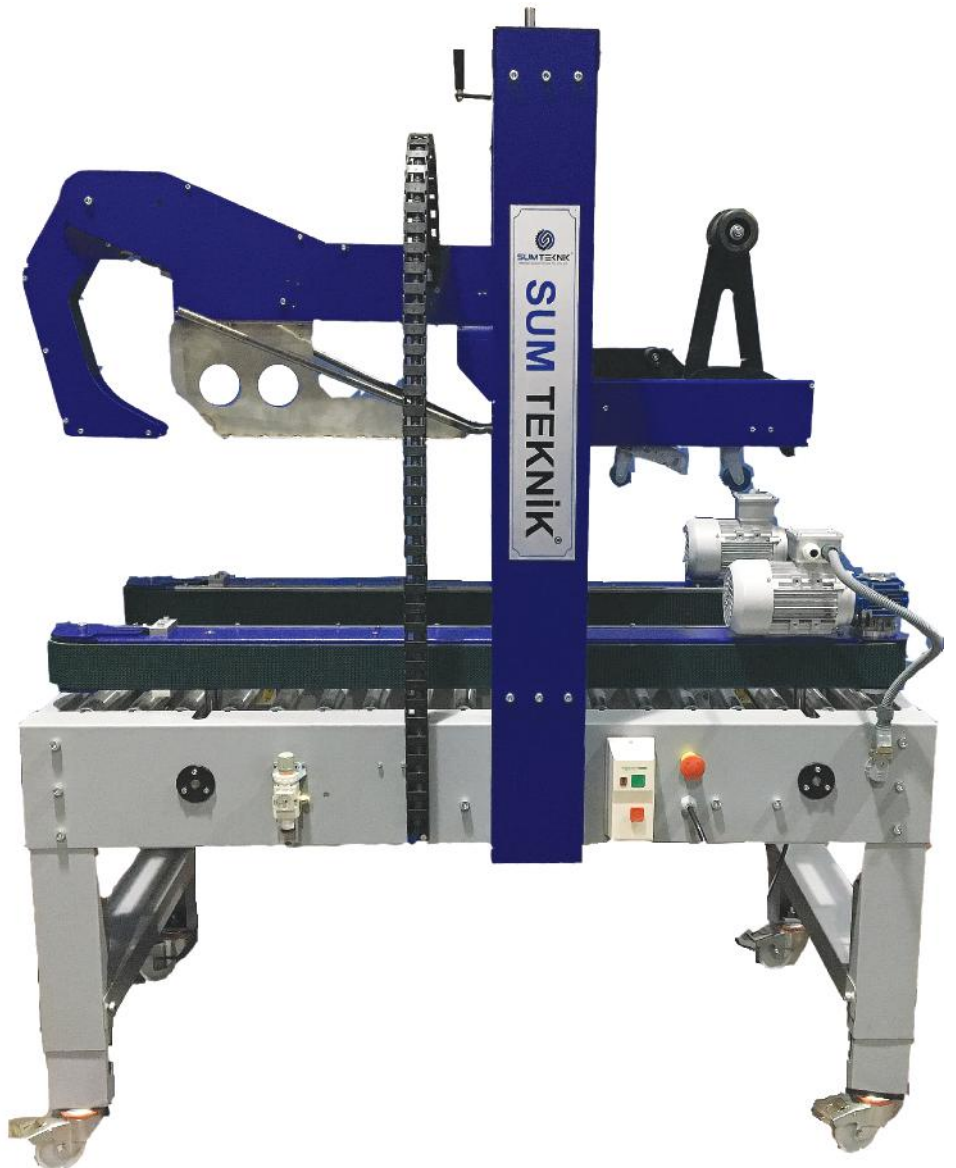
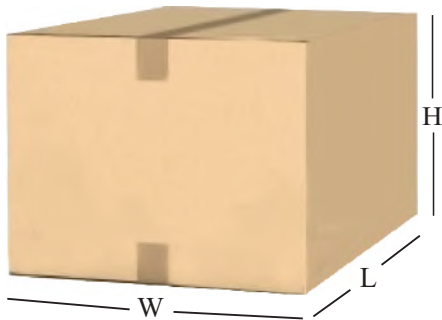

KH-AUTOMATIC CASE FORMER and SEALER

- ✓ The automatic case erectors is designed to erect, form and seal with tape the bottom flaps of boxes (Optionally hot melt)
 - ✓ Case dimensions min: (LxWxH) 220 x 180 x 100 mm
 - ✓ Case dimensions max: (LxWxH) 500 x 500 x 500 mm
 - ✓ Capacity: Max 14 case/minute, Optionally: 20 case/minute
 - ✓ Case magazine capacity: Max 130 case
 - ✓ Replaceable suction plate
 - ✓ Fast adjustment on box dimensions
 - ✓ Ready for integration into automatic lines
 - ✓ Electric connection: 0,5 kW, 220 V, 50 Hz
 - ✓ Tape width: 5 cm-2" (Opt. 7 cm-3")
 - ✓ Air consumption: 38, min 600 kPa, 1/2" connection
 - ✓ Colour: RAL 7040 - 5002
 - ✓ Touch screen HMI in 6 different languages (Turkish, English, German, French, Spanish, Arabic)
 - ✓ LG/LS PLC, SMC pneumatic equipments
 - ✓ CE certification
 - ✓ Made in Turkey
- * Requested air pressure: 5 - 6 bar

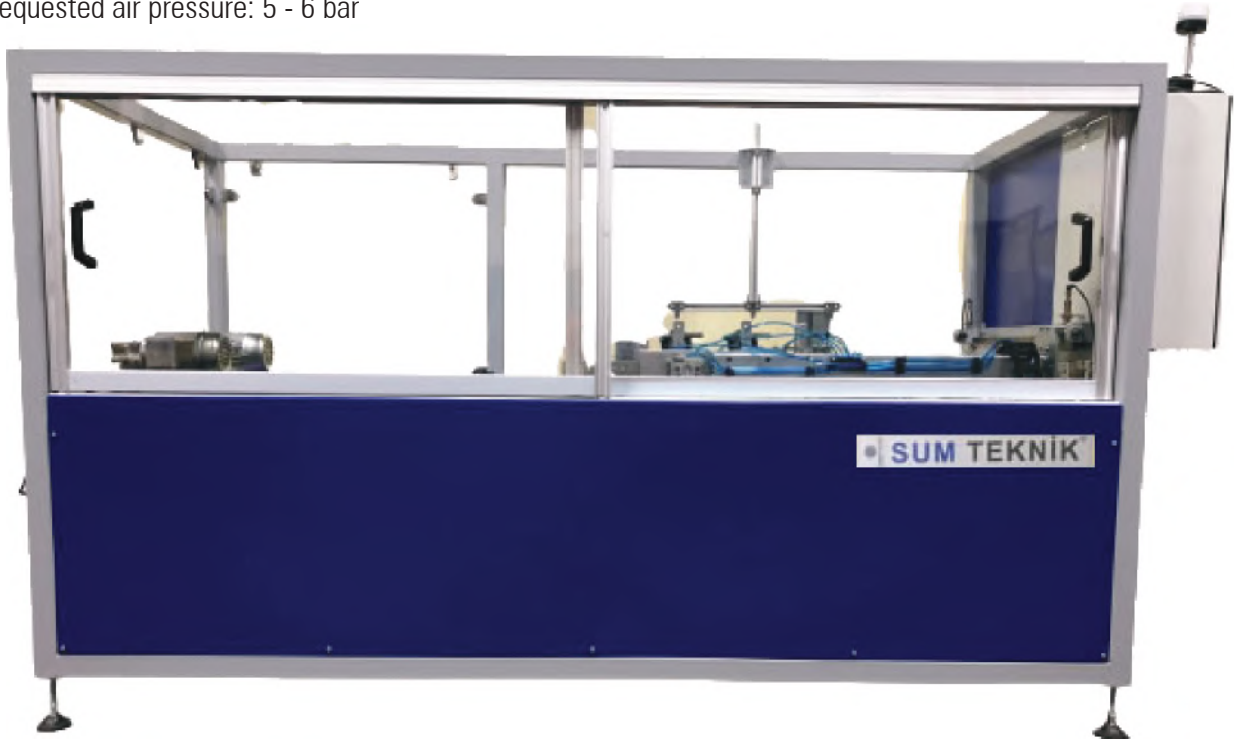
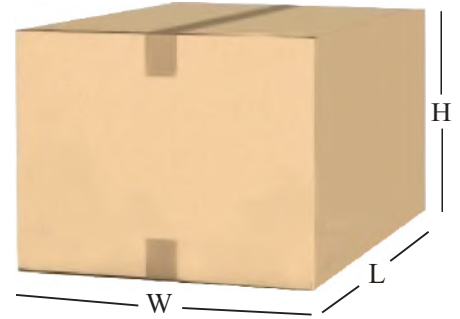

KA-ACCORDION



KB-BELT

(Size can change according to request.)



KM-MODULER



KR-ROLLER (Idle-Motorized)

(Size can change according to request.)



Motorised or Gravity conveyors can be produced according to specific request.



SUMTEKNİK

MAKİNE SANAYİ VE DIŞ TİC. LTD. ŞTİ.

SUM TEKNİK MAKİNE SAN. ve DIŞ TİC. LTD. ŞTİ.

Center: Barbaros Mah. Apaydın Sok. No.2 D.4
34746 Ataşehir - İstanbul / TURKEY

+90 216 411 47 85 +90 216 478 53 53

Production: İkitelli O.S.B. Atatürk Bulvarı Haseyaf
2. Kısım No: 100 2B01 Başakşehir - İstanbul / TURKEY

info@sumteknik.com.tr www.sumteknik.com.tr

Your Partner for all Industrial Engineering and Packaging Solutions...