

450 mm / 650 mm / 1000 mm 階規
CHECK MASTER



標準規格 Check Master			
型號 Model No.	CW-450L	CW-650L	CW-1000L
精確度 Accuracy	≤ 2 um	≤ 3 um	≤ 6 um
量測範圍 Range	0~450 mm	0~650 mm	0~1000 mm
環境溫度 Temperature	T = 20 ± 1°C		

垂直儀
VERTICAL TESTER



型號 Model No.	V-300	V-600
量測範圍 Range	0~300 mm	0~600 mm
精確度 Accuracy		
真直度 Straightness	≤ 3 um	≤ 5 um
垂直度 Squares	≤ 3 um	≤ 5 um
操作方式 Operation	手動 Manual	手動 Manual
重量 Weight	8Kg	10Kg
環境溫度 Temperature	T=20 - 23°C	T=20 - 23°C

 建緯精密科技股份有限公司
CHIEN WEI PRECISE TECHNOLOGY CO., LTD.

高雄總公司地址：高雄市鳳山區 830 鎮北里鎮北北巷 20-16 號
HEADQUARTERS
20-16, Chen Pei N. Lane, Chen Pei Li.
Fengshan Dist., 830 Kaohsiung City, Taiwan
TEL : 886-7-7313911 FAX : 886-7-7314976
E-Mail : info@chienwei.com.tw http://www.chienwei.com/
桃園辦事處地址：桃園縣八德市大明街 3 號
TEL : 886-3-3617817 FAX : 886-3-3618603
台中辦事處地址：台中市北屯區軍福十八路 13 號
TEL : 886-4-24373526 FAX : 886-4-24392589
昆山長豐精密儀器有限公司
KUNSHAN CHANGFENG PRECISE INSTRUMENTS CO., LTD.
江蘇省昆山市張浦鎮大市中山路 12 號
TEL : 86-512-57258001 FAX : 0512-57258006
E-Mail : kschangfeng@163.com

※本公司保留對此型錄做修改之權利，修改時恕不另行通知。(2014-11)
※Chien Wei reserves the right to change specifications without notice.



建緯精密科技股份有限公司
CHIEN WEI PRECISE TECHNOLOGY CO.,LTD.



CNC 高精度治具研磨機
CNC HIGH PRECISION JIG GRINDING MACHINE

JG 510CM

PRECISION JIG GRINDER

高精度治具研磨機



JG-510CM

1. 控制器：FANUC 31i controller
2. 同機實現精密異形輪廓研削。
3. X、Y、Z、CS 四軸同時控制。
4. 垂直研削機能直覺式操控。
5. 開機診斷全自動異常輸出。
6. 面板調控研磨頭動力輸出。
7. 加工行程：500 x 300 x 100 mm (X , Y , Z)

8. 最大載重：300kg
9. 最大進給速率：10000 mm / min (X , Y , Z)
10. 解析度：XYZ 軸：0.01 um
11. 位置取決精度 X , Y 軸：+/- 0.0015 mm
12. 游星研磨真圓度 \leq 0.001 mm
13. Z 軸由線性馬達作高速、高精度動力傳輸。
14. 12 組進刀軸設定。

JG-510CM

1. Controller: FANUC 31i
2. Implementable of diverse shape grinding
3. capability of synchronize movement of 4 axis (X, Y, Z, CS)
4. Friendly chopping operation
5. Abnormity detecting capability when power on
6. Adjustment of grinding head power output by LCD control panel
7. Working Travel: 500 X 300 X 100 mm (X, Y, Z)

8. MAX load: 300kgs
9. MAX feeding speed: 10000 mm / min (X,Y,Z)
10. Resolution: 0.01 μ m
11. Positioning accuracy subject to X, Y axis : +/- 0.0015 mm
12. Planetary grinding roundness \leq 0.001 mm
13. Z axis is driven by high-speed precise linear motor.
14. 12 grinding setting modes

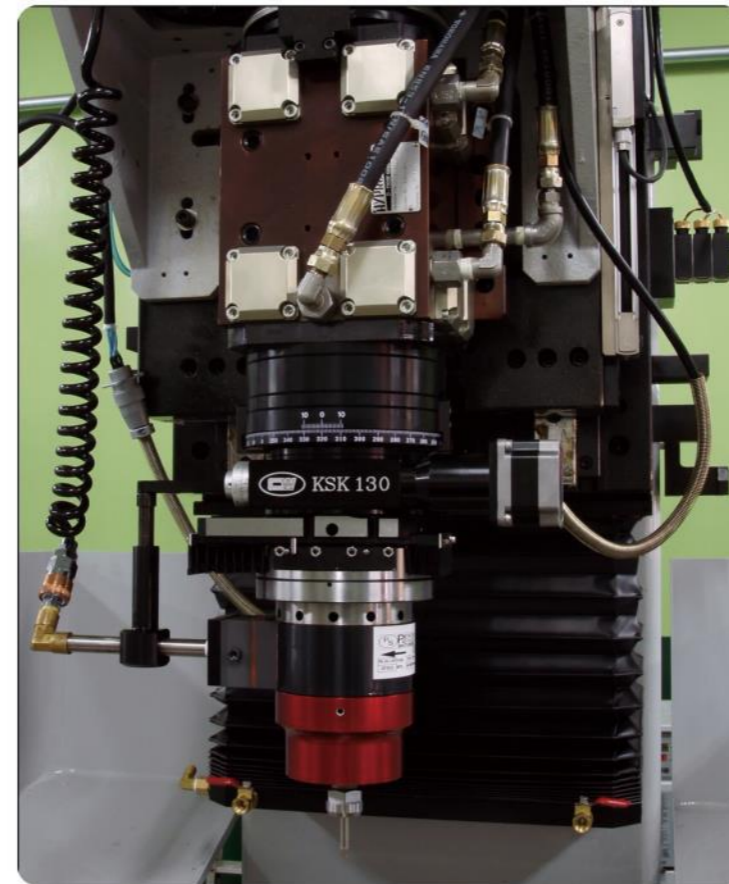
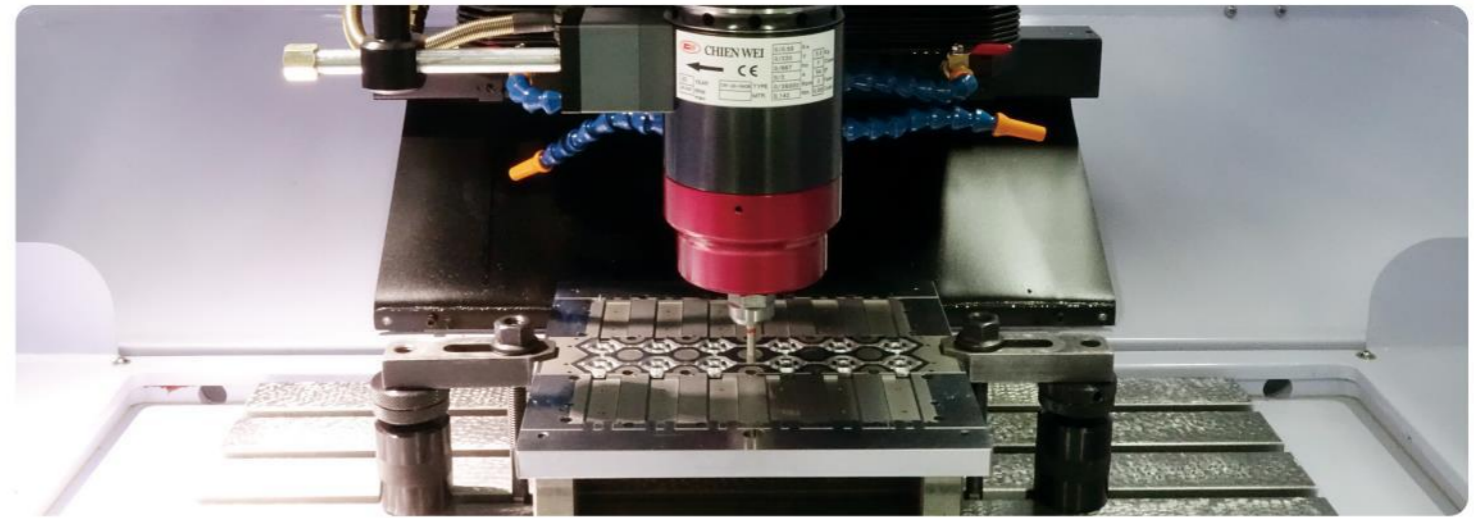

↑ IC 封裝模具加工 IC Packaging

← 德國製油靜壓主軸 German-made Hydrostatic Spindle

↓ 液靜壓幫浦 Hydraulic power unit

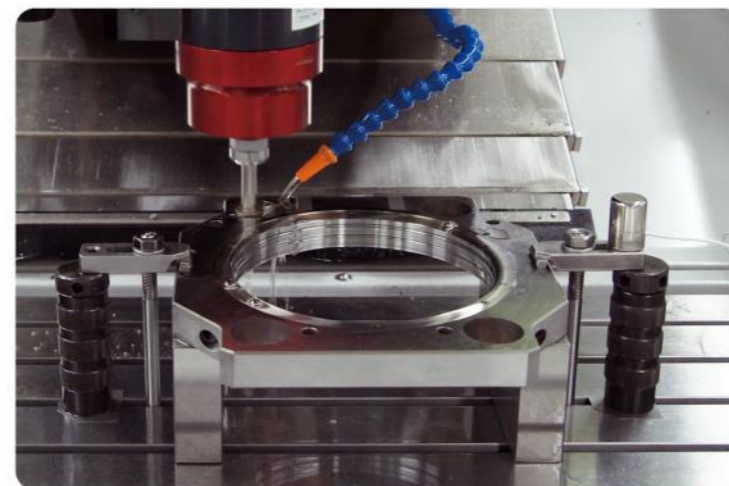

精密模具件加工 High precision mold

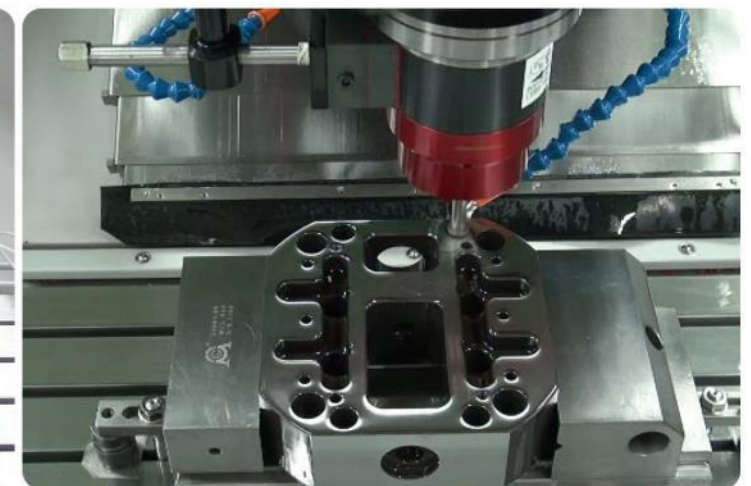

精密零組件加工 High accurate component

JG 510GC

PRECISION JIG GRINDER

內齒輪研磨機



JG-510GC 內齒輪研磨機 (Groove Grinder)

FANUC 控制器
 X / Y / Z 移動行程 : (500 X 300 X 100)
 定位精度 (X / Y / Z) : ± 0.0015 mm
 CNC 自動進刀研磨
 具有自動修砂自動補正功能
 BLUM (波龍) 自動量測系統
 第四軸 (JAPAN)
 採用德國液靜壓主軸
 砂輪法蘭 (X2), 皮帶 (X2)

Fanuc Cotroller
 X / Y / Z travel: 500 x 300 x 100 mm
 Positioning accuracy (X/Y/Z): ± 0.0015 mm
 Automatic feed
 Automatic dressing and compensation
 Automatic measuring system
 Rotary table
 Hydrostatic spindle
 Wheel flange (X2), Belt (X2)



JG-510GC 外齒輪研磨機 (Gear Grinder)

FANUC 控制器
 X / Y / Z 移動行程 : (500 X 300 X 100)
 定位精度 (X / Y / Z) : ± 0.0015 mm
 CNC 自動進刀研磨
 具有自動修砂自動補正功能
 BLUM (波龍) 自動量測系統
 第四軸 (加裝光學尺 選配)
 高速電動研磨頭 12000 rpm
 $\psi 150$ 強力磁盤
 延伸桿 (X2)

Fanuc Cotroller
 X / Y / Z travel: 500 x 300 x 100 mm
 Positioning accuracy (X/Y/Z): ± 0.0015 mm
 Automatic feed
 Automatic dressing and compensation
 Automatic measuring system
 Rotary table
 Electrical grinding head (12000 rpm)
 $\psi 150$ Magnetic disc
 Extension (X2)



JG 510GC

PRECISION JIG GRINDER

外齒輪研磨機



JG 1270CM

PRECISION JIG GRINDER

高精度治具研磨機



可並用第四軸作等分連續圓孔加工 Capable of synch the 4th axis for machining process

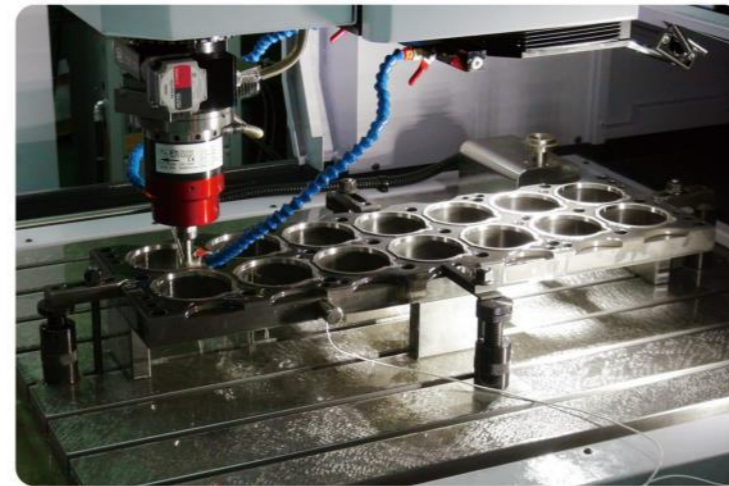

杯型模具加工 Cup mold

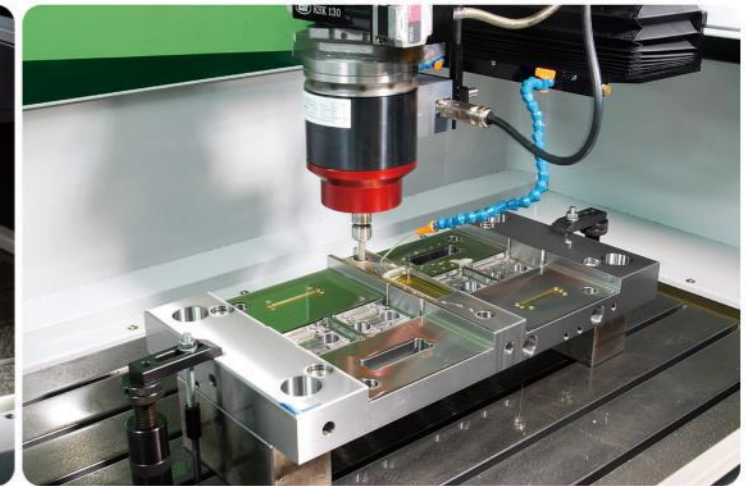

精密塑膠模座加工 Housing of high sophisticated plastic mold

JG-1270CM

1. 控制器：FANUC 31i controller
2. 同機實現精密異形輪廓研削。
3. X、Y、Z、CS 四軸同時控制。
4. 垂直研削機能直覺式操控。
5. 開機診斷全自動異常輸出。
6. 面板調控研磨頭動力輸出。
7. 加工行程：1200 x 700 x 100 mm (X , Y , Z)

8. 最大載重：1000kg
9. 最大進給速率：10000 mm / min (X , Y , Z)
10. 解析度：XYZ 軸：0.01 um
11. 位置取決精度 X , Y 軸：+/- 0.0015 mm
12. 游星研磨真圓度 \leq 0.001 mm
13. Z 軸由線性馬達作高速、高精度動力傳輸。
14. 12 組進刀軸設定。

JG-1270CM

1. Controller: FANUC 31i
2. Implementable of diverse shape grinding
3. capability of synchronize movement of 4 axis (X, Y, Z, CS)
4. Friendly chopping operation
5. Abnormity detecting capability when power on
6. Adjustment of grinding head power output by LCD control panel
7. Working Travel: 1200 X 700 X 100 mm (X, Y, Z)

8. MAX load: 1000kgs
9. MAX feeding speed: 10000 mm / min (X, Y, Z)
10. Resolution: 0.01 μ m
11. Positioning accuracy subject to X, Y axis : +/- 0.0015 mm
12. Planetary grinding roundness \leq 0.001 mm
13. Z axis is driven by high-speed precise linear motor.
14. 12 grinding setting modes



油霧回收器 Lubricant mist collector



液靜壓幫浦 Hydraulic power unit

JG 1010G

PRECISION JIG GRINDER
龍門型高精度治具研磨機

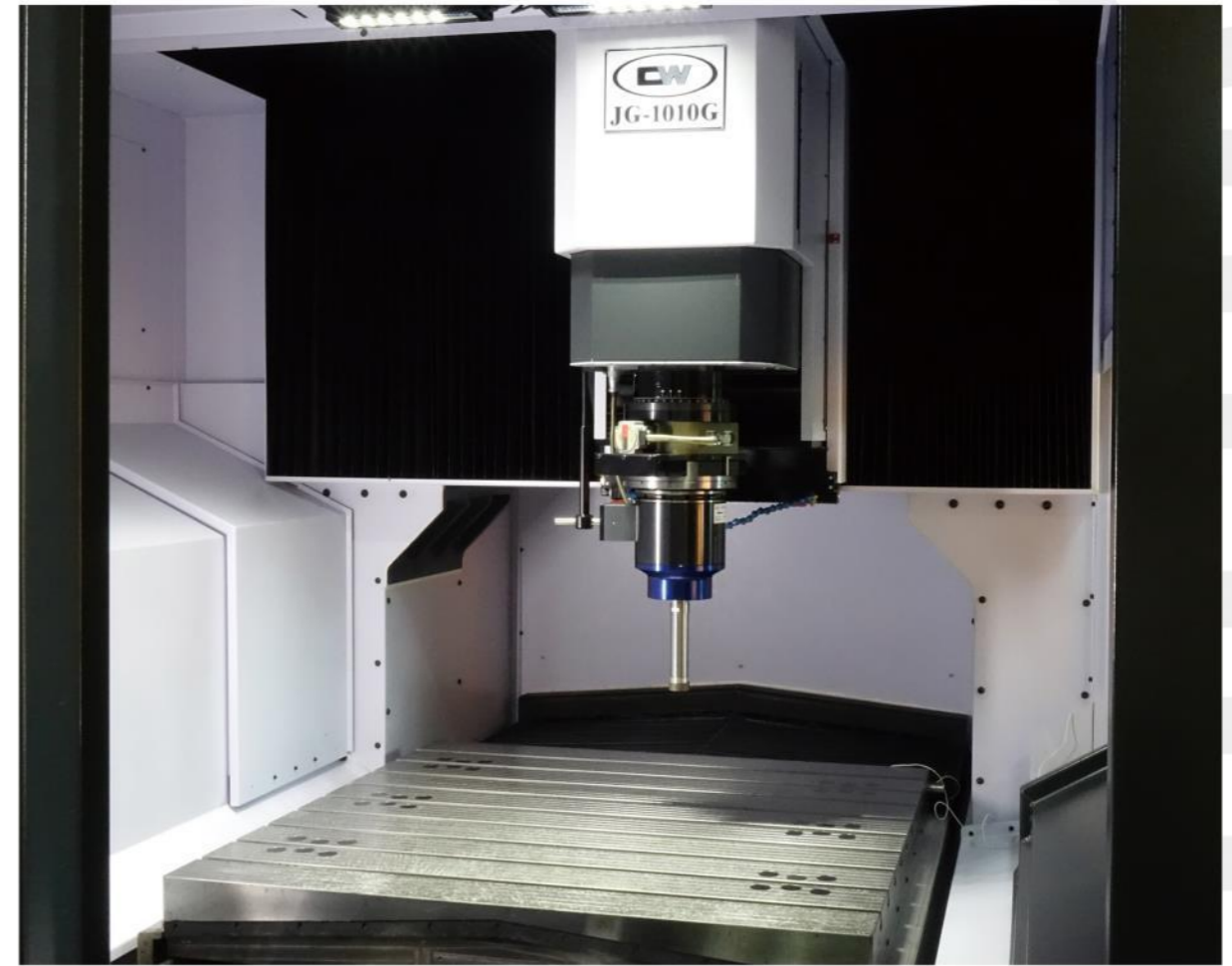

JG-1010G 特色

機器名稱：龍門型高精度治具研磨機

機器特性：

JG-1010G 龍門型高精度治具研磨機，底座及橫樑採用花崗岩構件所組成的結構體，主要是利用花崗石的特性，震動阻尼良好、動態特性佳，大大改善加工件的表面光度，此外，花崗岩的熱傳導係數低，受熱源及大環境溫度變化影響小，故能維持機台的穩定度，提昇加工件精度穩定性，而且花崗岩不生鏽、耐酸鹼，無須特別保養。

JG-1010G (X / Y / W) 三軸馬達與精密高速滾珠螺桿採直結式傳動，增強剛性及提高精密密度。

採用 C1 級精密滾珠螺桿，螺桿作 3°C 溫昇伸長量預拉，有效提高剛性降低軸向負荷變形。

FANUC 控制器：31i

X / Y / Z / W 移動行程：(1000 x 1000 x 250 x 400 mm)

床台平面度 ≤ 0.01 mm

(X / Y / Z) 三軸採用重負荷 NSK(P4 超精密級) 滾柱型線性滑軌，軌道面寬 45 mm，滑塊滾柱與軌道接觸面積大，軌道接觸面彈性變形量小、強度大、吸震係數高。快速移位 X / Y / Z 軸 24 m / min。

Z 軸進給採用線性馬達作為動力傳輸，主要是利用線性馬達的特性，高響應性、直驅傳動高剛性，且具有高速、高加速度性、無背隙誤差等，不但簡化 Z 軸結構，而且大幅提昇工作效率，實現高速、超高精度的加工。

JG-1010G 結構體設計，增加兩層德製防震墊材質，隔絕內、外部的震源，確保加工件高精度的品質。搭配高頻研磨主軸，提升研磨加工效率。

定位精度 (X / Y / Z)： ± 0.0015 mm

重覆精度 (X / Y / Z)： ± 0.001 mm

JG-1010G

MODEL: JG-1010G DOUBLE COLUMN JIG GRINDER

Feature :

JG-1010G double column Jig Grinder with superstructure fabricated by granite, which is well-known by its excellent damping, low heat conductivity, rust-proof, and corrosion resistance, is capable of stabilizing the machine accuracy and enhancing the roughness on workpiece.

Stiffness and accuracy is also enhanced with the motors on three axis (X, Y, W) direct-driven design transmission.

C1 grade ballscrew was adopted, pre-tension by 3°C in temperature increment, which is effectively upgrading stiffness and preventing from deformation during operation.

FANUC controller:31i

X,Y,Z,W travel: 1000 X 1000 X 250 X 400 mm

Plate Flatness ≤ 0.01 mm

NSK P4 heavy load ultra precise linear guideway with rail width of 45 mm is adopted in 3 axis (X, Y, Z) and has a wider engagement in order to a low deformation, high strength, vibration resistance as well as capability of max feed speed of 24 m/min.

Feeding movement of Z axis is driven by linear motor, which features instrument with hyperresponsiveness, rigidity, high speed, excellent acceleration, and no backlash and not only simplifies the superstructure but also fulfills rapid and precise machining process.

Besides, the two additional German-made vibration insulation pads are also incorporated inside to assure the accuracy and quality.

Position accuracy: ± 0.0015 mm

Repeatability: ± 0.001 mm

JG-510CM / JG-1270CM

Samples of Finished Parts

研磨加工範例圖

	粗加工 Rough Cut	精加工 Finish Machining
=SKD11 HRC 62° 材質		
砥石 Grinding Pencil (or Grinding Wheel)	(CBN#150)	(CBN#150)
砥石回轉速 Rotating Speed	40,000 rpm	40,000 rpm
預留量 Reserving	0.2 mm	0.015 mm
進給率 Cutting Feed Rate	40 mm / min	20 mm / min
進刀量 Cutting Feed	0.1 mm	0.005 mm
加工時間 Process Time	約 12 分鐘 About 12 minutes	約 20 分鐘 About 20 minutes

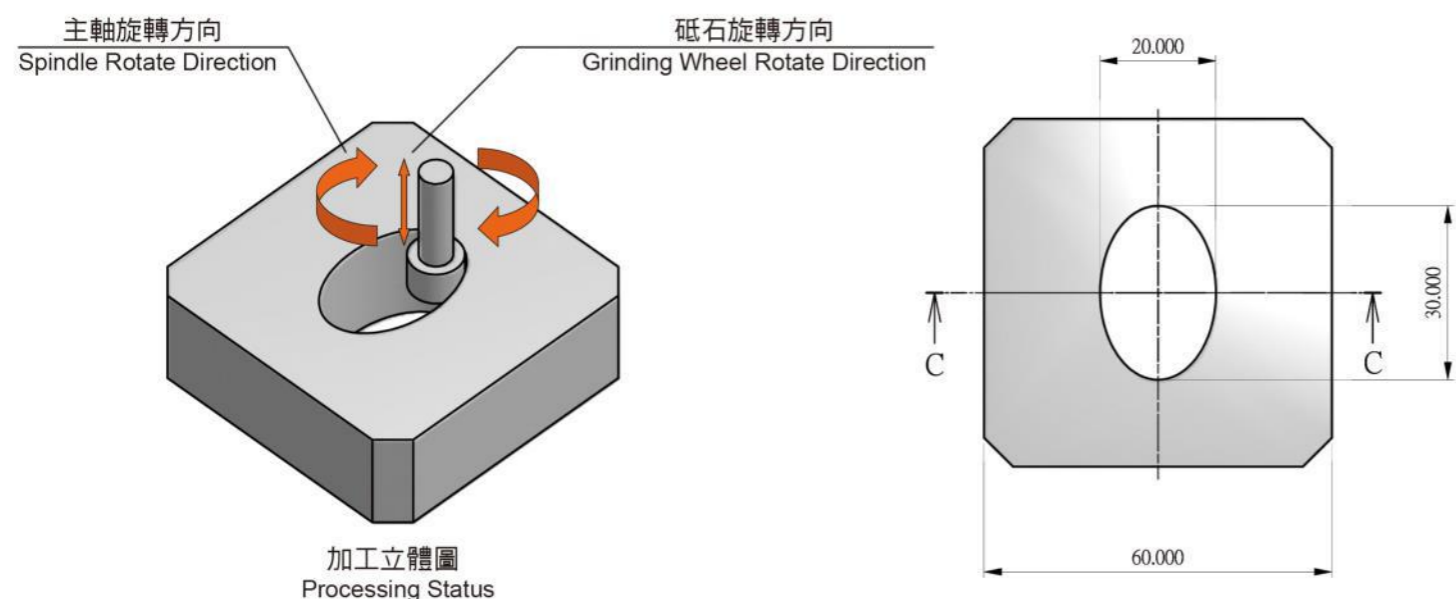

使用砥石 Using Grinding Wheel (CBN#150)



C-C (1:1)

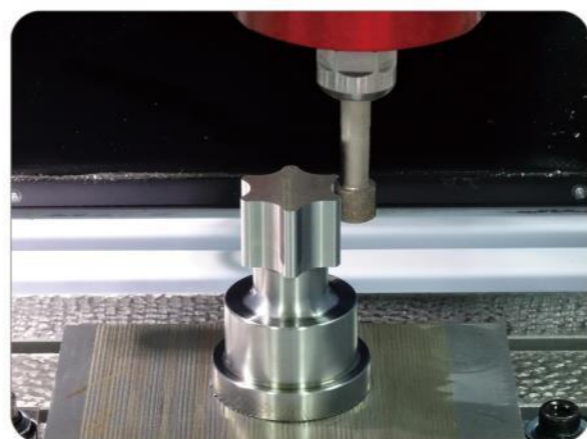
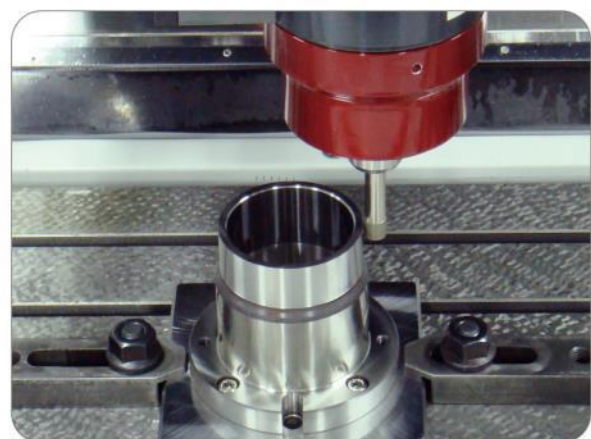

研磨加工示意圖 Processing Drawing

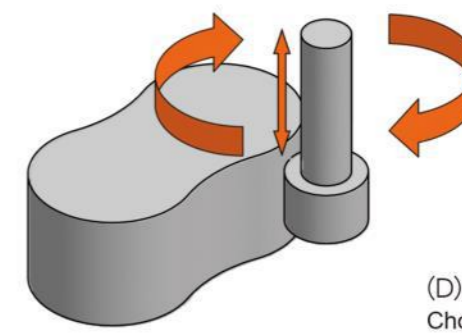
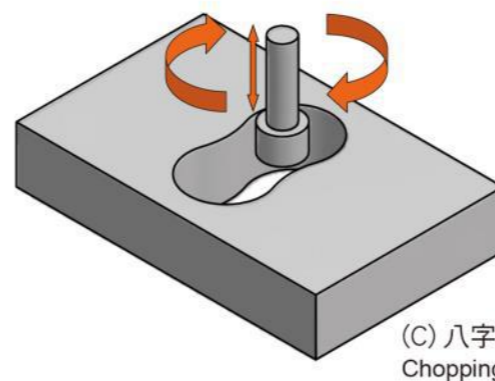
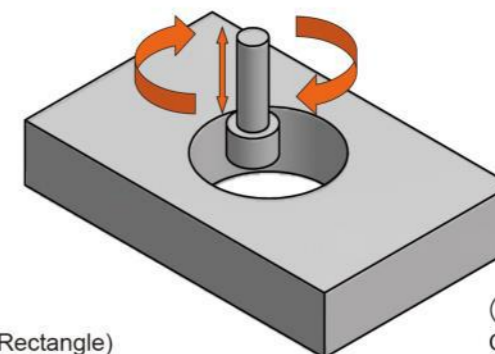
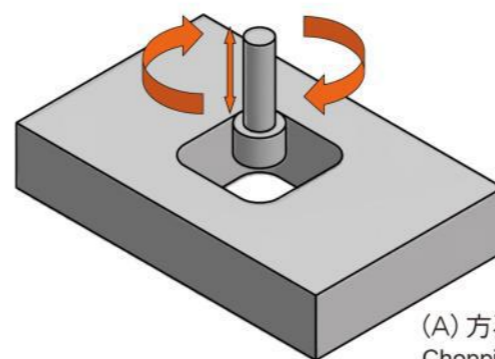

JG-510CM 研削磨樣品參考 JG-510CM Chopping Finished Parts



JG-510CM / JG-1010G / JG-1270CM

Machine Specifications

精密治具研磨機規格表

1. 滑台作業範圍 WORK RANGE OF THE SLIDES

移動範圍 RANGE OF MOVEMENT		JG-510CM	JG-1010G	JG-1270CM
工作台移動量 (左右)[X 軸]	X Axis	500 mm (19.7")	1000 mm (39.4")	1200 mm (39.4")
滑台移動量 (前後)[Y 軸]	Y Axis	300 mm (11.8")	1000 mm (39.4")	700 mm (27.6")
研磨頭移動量 (上下)[Z 軸]	Z Axis	100 mm (3.9")	250 mm (9.8")	100 mm (3.9")
主軸移動量 (上下)[W 軸]	W Axis	340 mm (13.4")	400 mm (15.7")	360 mm (15.7")

最大進給速度 Max FEED SPEED

X,Y 軸	X,Y Axis	10 m / min	24 m / min	10 m / min
Z 軸	Z Axis		24 m / min	24 m / min

解析度 READING RESOLUTION

X,Y 軸	X,Y Axis		0.01 um	
Z 軸	Z Axis		0.01 um	
Cs 軸	Cs Axis		0.001 deg	

定位精度 LOCATION ACCURACY

X,Y 軸	X,Y Axis	±0.0015 mm	±0.0015 mm	±0.0015 mm
-------	----------	------------	------------	------------

位置檢出器 POSITION CODER

X,Y 軸	X,Y Axis		Linear encoder	
Z 軸	Z Axis		Linear encoder	
Cs 軸	Cs Axis		Magnetic sensor	

工作台 TABLE

作業面積 (長 X 寬)	Table area (LxW)	700 x 340 mm (27.6" x 13.4")	1200 x 1200 mm (47.2" x 47.2")	1280 x 860 mm (50.4" x 33.9")
最大載重	permissible load (max.)	300 kg	1500 kg	1000 kg
T 溝數量	Number of T-slot	5	9	8
T 溝形狀	Shape of T-slot	10.0 mm (width)	12.0 mm (width)	10.0 mm (width)

2. 研磨頭作業範圍 WORK RANGE OF THE GRINDING HEAD

研磨頭主軸速度	Grinding-spindle speeds			
電動研磨頭 (最高)	Electrical grinding head (max.)		30000 rpm or 40000 rpm	
氣動高速研磨頭 (最高)	With high speed grinding head (max.)		60000 rpm	
行星回轉速度	Planetary speed		5~200 rpm	
研磨直徑	Bore-diameter capacity	0.5~100 mm (0.02"~3.9")	0.5~250 mm (0.02"~9.8")	0.5~100 mm (0.02"~3.9")
砂輪最大直徑	Max.diameter of wheel	Ø30 mm (dia 1.2")	Ø180 mm (dia 7.1")	Ø30 mm (dia 1.2")
套筒	Collets		Ø3, Ø6, Ø10 mm	
進刀軸最小進給量 (U 軸)	U Axis last input increment		0.001 mm	
最大移動行程	U Axis max.stroke		30 mm (1.18")	
冷卻 (空氣)	Cooling Self by input		Air	
潤滑 (油霧)	Lubrication		Oil-mist	
重量	Weight		3.5 kg	

3. 馬達 Motor

		JG-510CM	JG-1010G	JG-1270CM
X 軸 (Servo)	X Axis	1.4 KW (4Nm)	4.0 KW (22Nm)	3.0 KW (12Nm)
Y 軸 (Servo)	Y Axis	1.6 KW (8Nm)	4.0 KW (22Nm)	3.0 KW (12Nm)
W 軸 (Servo)	W Axis	1.4 KW (4Nm)	1.6 KW (8Nm)	1.6 KW (8Nm)
Z 軸 (線性馬達)	Z Axis	3.2 KW	6.8 KW	3.2 KW
Cs 軸	Cs Axis			0.55 KW Spindle
U 軸	U Axis			Stepping

4. 外形尺寸及重量 OUTER DIMENSIONS AND WEIGHT

長	Length	2780 mm	4600 mm	3392 mm
寬	Width	2733 mm	4000 mm	2609 mm
高 (最大)	Height (Max.)	2675 mm	3600 mm	3000 mm
高 (最小)	Height (Min.)	2325 mm		2745 mm
重量	Weight	5010 kg	12500 kg	7200 kg

5. 動力需求 POWER REQUIREMENT

電壓	Voltage	220v ± 10	220v ± 10%	220v ± 10
最大消耗電力	Max. Voltage consumption	13 KW	17.5 KW	15 KW
氣壓	Compressed air	7 kg / cm ²	7 kg / cm ²	7 kg / cm ²
最大消耗流量	Air consumption	420 nl / min	420 nl / min	420 nl / min

6. 數值控制器功能 NC CONTROLLER FUNCTION

數值控制器	Nc Controller	FANUC 31i	FANUC 31i	FANUC 31i
控制軸數	Number of controlled axes	20 axes	20 axes	20 axes
同動控制軸數	Simultaneously controlled axes		4 axes	
Cs 輪廓控制	Cs contouring control		1 axis	
垂直研削功能	Chopping function		Built-in	
最小設定單位	Last input increment		0.0001 mm / 0.0001 deg	
最大行程	Max. stroke		±9999.9999 mm / ±9999.9999 deg	
快速位移	Rapid traverse Max		10 m / min	
快速位移控制	Rapid traverse override		F0,25,50,100	
進給速率單位	Feed per minute		mm / min	
手輪進給	Manual handle feed		4 axes	
手輪進給速率	Manual handle feed rate		x1,x10,x100,x1000	
程式碼 (自動識別)	Tape code (auto.recognition)		EIA / ISO	
程式儲存長度	Length storage by program		640 m	
同位檢查	Parity check		Horizontal and vertical parity	

7. 標準週邊配備樣式表 ACCESSORIES / 數量 Q'ty

1. 小型千斤頂	Mini Jack S75	4	10. 保養工具	Maintenance Tool Box	1	19. 助聽器	Hearing Aid	1 set
2. 小型千斤頂	Mini Jack S95	4	11. 單向壓板	Clamping Chuck 12 X 65 L	4	20. 工作燈	Light	1 set
3. 小型千斤頂	Mini Jack S125	4	12. 單向壓板	Clamping Chuck 12 X 80 L	4	21. 環規	Indicator	1 set
4. T 型螺絲	Screw M12x50L	4	13. 單向壓板	Clamping Chuck 12 X 100 L	4			
5. T 型螺絲	Screw M12x75L	4	14. 量表支持架	Dial Gauge Frame	2 sets			
6. T 型螺絲	Screw M12x100L	4	15. 冷切油槽	Cooling Oil Tank	1 set			
7. T 型螺絲	Screw M12x125L	4	16. 電動機油注油機	Electric grease lubricator	1 set			
8. T 型螺絲	Screw M12x150L	4	17. 循環式水冷卻機	Cooler (Cycle Type)	1 set			
9. 法蘭螺帽	Flange Nut M12	4	18. CBN 鑄磨棒	CBN Grinding Tool	1 set			

JG-510GC

Machine Specifications

齒輪研磨機規格表

1. 滑台作業範圍 WORK RANGE OF THE SLIDES

移動範圍 RANGE OF MOVEMENT		JG-510GC (外齒 gear)	JG-510GC (內齒 groove)
工作台移動量 (左右)[X 軸]	X Axis	500 mm(19.7")	500 mm(19.7")
滑台移動量 (前後)[Y 軸]	Y Axis	300 mm(11.8")	300 mm(11.8")
研磨頭移動量 (上下)[Z 軸]	Z Axis	100 mm(3.9")	100 mm(3.9")
主軸移動量 (上下)[W 軸]	W Axis	340mm(13.4")	340mm(13.4")

最大進給速度 Max FEED SPEED

X,Y 軸	X,Y Axis	10m/min
Z 軸	Z Axis	24m/min

解析度 READING RESOLUTION

X,Y 軸	X,Y Axis	0.01 um
Z 軸	Z Axis	0.01 um

定位精度 LOCATION ACCURACY

X,Y 軸	X,Y Axis	±0.0015mm
第四軸 (NC 分度盤)- 分割精度	Indexing accuracy	±5"
第四軸 (NC 分度盤)- 重覆精度	Repeatability accuracy	±1"

位置檢出器 POSITION CODER

X,Y 軸	X,Y Axis	Linear encoder
Z 軸	Z Axis	Linear encoder
第四軸 (NC 分度盤)	NC Rotary Table	Measuring angles with angle encoders (選配 optional)

工作台 TABLE

作業面積 (長 X 寬)	Table area (LxW)	700x340mm (27.6"x13.4")	700x340mm (27.6"x13.4")
最大載重	permissible load (max.)	300 kg	300 kg
T 溝數量	Number of T-slot	4	4
T 溝形狀	Shape of T-slot	18.0mm(width)	18.0mm(width)
第四軸 (NC 分度盤)	NC Rotary Table	170.0mm(盤面直徑)	200.0mm(盤面直徑)

2. 研磨頭作業範圍 WORK RANGE OF THE GRINDING HEAD

電動研磨頭 (最高)	Electrical grinding head (max)	12000 rpm	4000 rpm
砂輪最大直徑	Max.diameter of wheel	Ø100 mm(dia 3.9")	Ø70 mm(dia 2.75")
研磨最大工件外徑	Grindable work O.D.	Ø150 mm(dia 5.9")	Ø200 mm(dia 7.85")
研磨最小工件內徑	Grindable work I.D.		Ø80 mm(dia 3.15")
冷卻 (空氣)	Cooling Self by input		Air
型號	Type	CW - JG - 3	

3. 馬達 Motor		JG-510GC (外齒 gear)	JG-510GC (內齒 groove)
X 軸 (Servo)	X Axis	1.4KW	1.4KW
Y 軸 (Servo)	Y Axis	1.6KW	1.6KW
W 軸 (Servo)	W Axis	1.4KW	1.4KW
Z 軸 (線性馬達)	Z Axis	3.2KW	
第四軸 (NC 分度盤)	NC Rotary Table	1.4KW	1.4KW

4. 外形尺寸及重量 OUTER DIMENSIONS AND WEIGHT

長	Length	2780 mm	2780 mm
寬	Width	2733 mm	2733 mm
高 (最大)	Height (Max.)	2675 mm	2675 mm
高 (最小)	Height (Min.)	2325 mm	2325 mm
重量	Weight	5010 kg	5010 kg

5. 動力需求 POWER REQUIREMENT

電壓	Voltage	220v ± 10%
最大消耗電力	Max. Voltage consumption	13 KW
氣壓	Compressed air	7 kg/cm ²
最大消耗流量	Air consumption	420 nl/min

6. 數值控制器功能 NC CONTROLLER FUNCTION

數值控制器	Nc Controller	FANUC 31i	FANUC 31i
控制軸數	Number of controlled axes	26 axes	26 axes
同動控制軸數	Simultaneously controlled axes	4 axes	
垂直研削功能	Chopping function	Building in	
最小設定單位	Last input increment	0.0001 mm/ 0.001 deg	
最大行程	Max. stroke	±9999.9999mm /±9999.9999 deg	
快速位移	Rapid traverse Max	100 m/min	
快速位移控制	Rapid traverse override	F0,25,50,100%	
進給速率單位	Feed per minute	mm/min	
手輪進給	Manual handle feed	4 axes	
手輪進給速率	Manual handle feed rate	x1,x10,x100,x1000	
程式碼 (自動識別)	Tape code (auto.recognition)	EIA/ISO	
程式儲存長度	Length storage by program	640 m	
同位檢查	Parity check	Horizontal and vertical parity	

7. 自動線上量測 Automatic online measurement

波龍量測系統	BLUM	TC76-N	TC76-N
測針	Stylus	ψ2	ψ2

8. 砂輪修整器 Dresser

砂輪外徑	Wheel O.D.	r2(ψ100) · r1(ψ80) · r0.8(ψ80)	r2(ψ100) · r1(ψ80) · r0.8(ψ80)
鑽石筆夾角	Angle of Diamond dresser	60°	60°

9. 標準週邊配備樣式表 ACCESSORIES / 數量 Q'ty

延伸桿	Extension	2	
砂輪法蘭	Wheel flange		2
皮帶	Belt		2

JG-510CM

External Dimension for Precise Jig Grinder

精密治具研磨機外觀尺寸圖

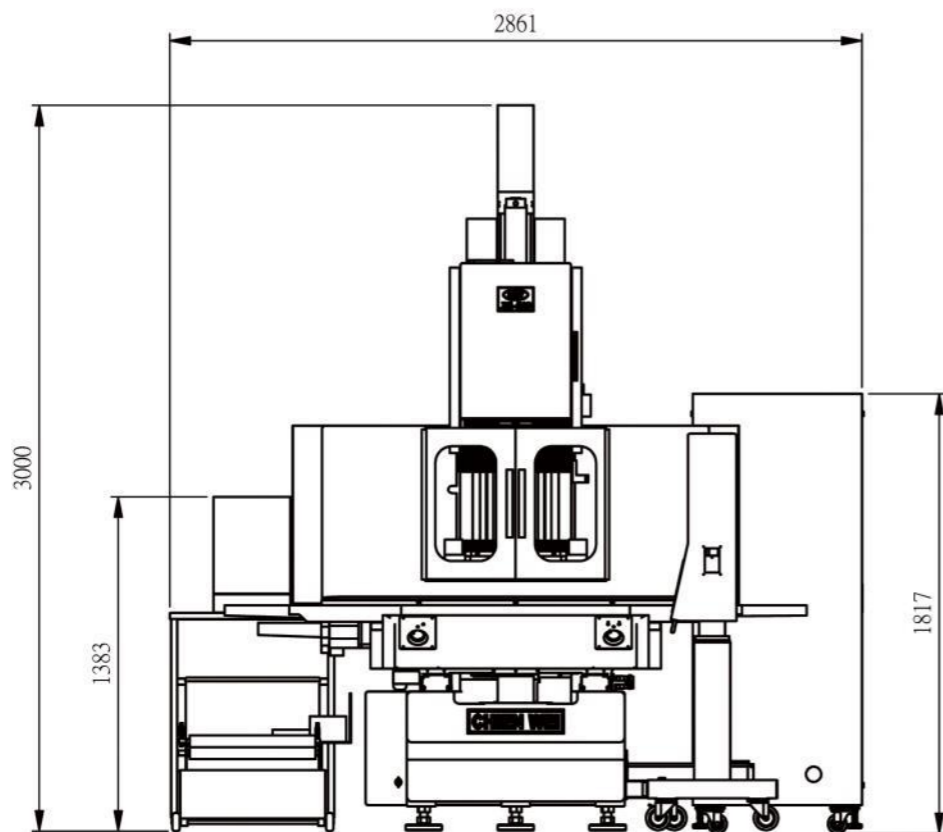
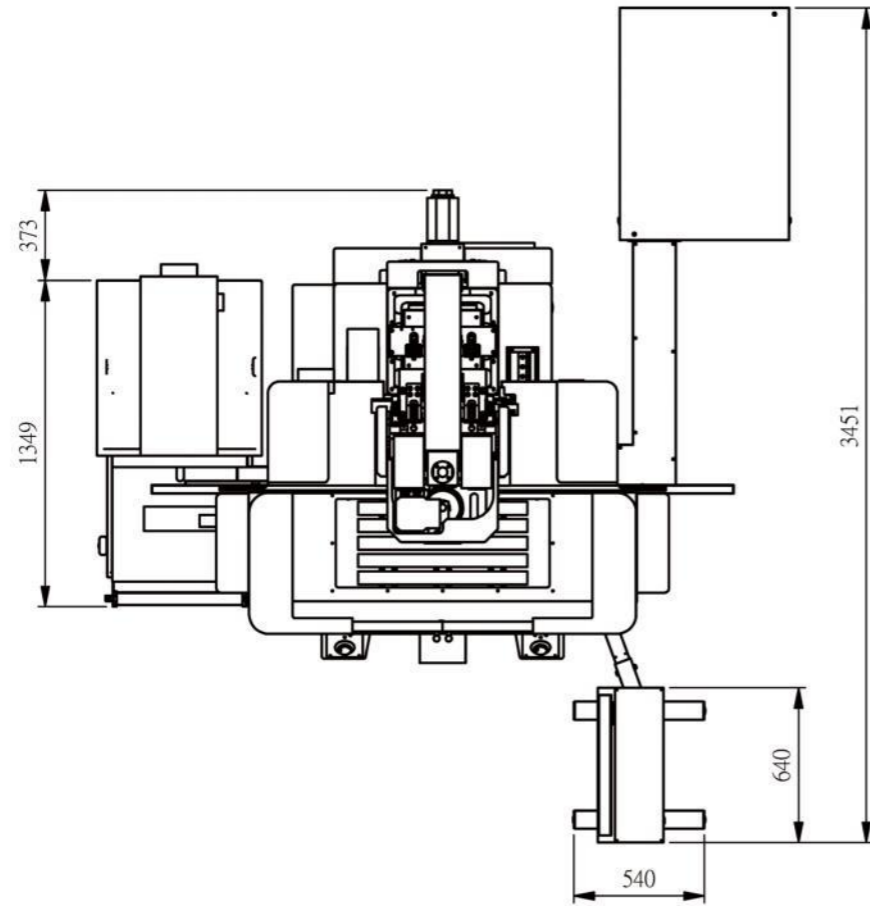
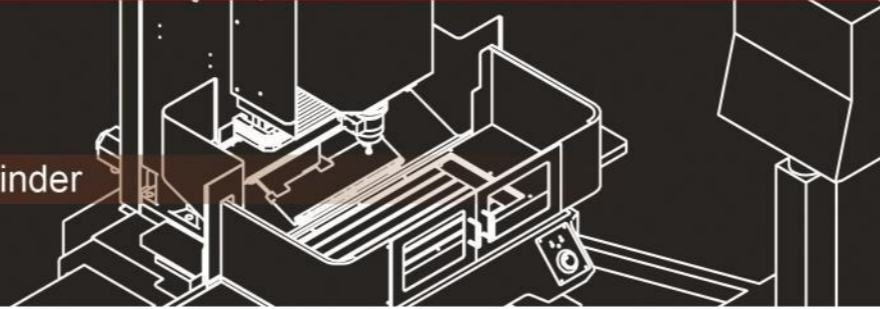

JG-1010G

External Dimension for Double-Columned Jig Grinder

龍門型高精度治具研磨機外觀尺寸圖

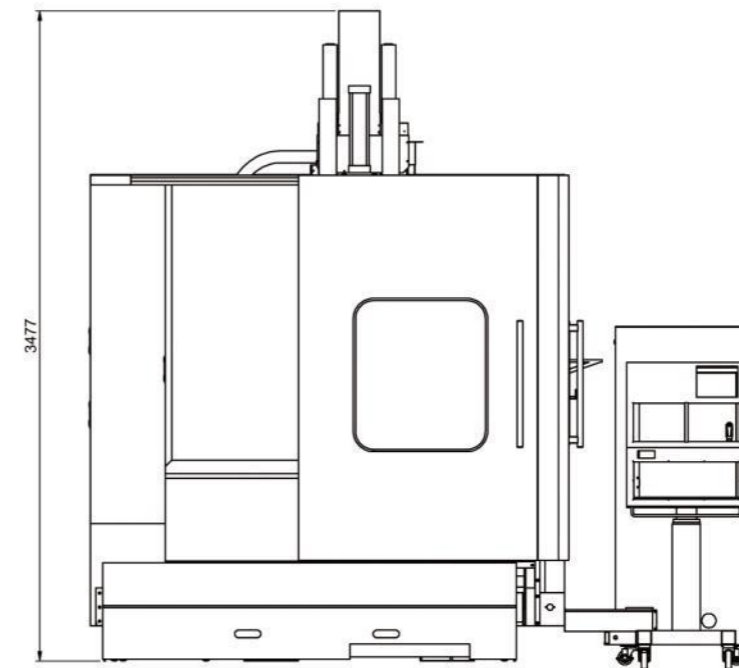
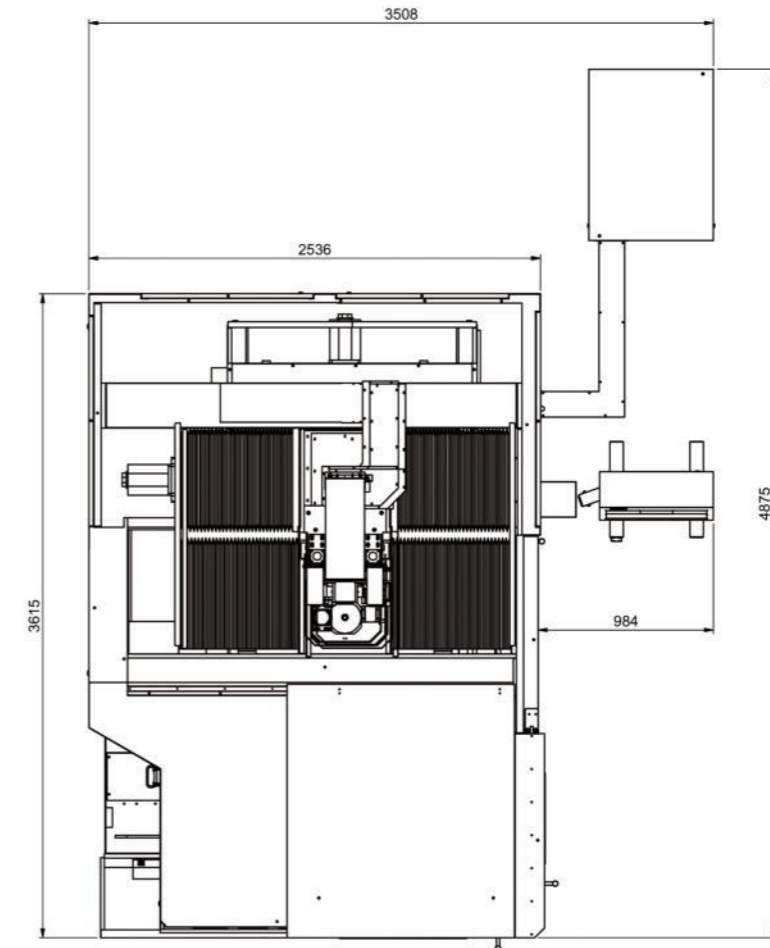
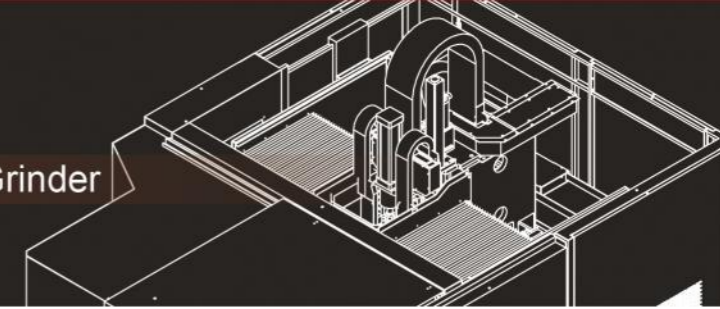

JG-1270CM

External Dimension for Precise Jig Grinder

精密治具研磨機外觀尺寸圖

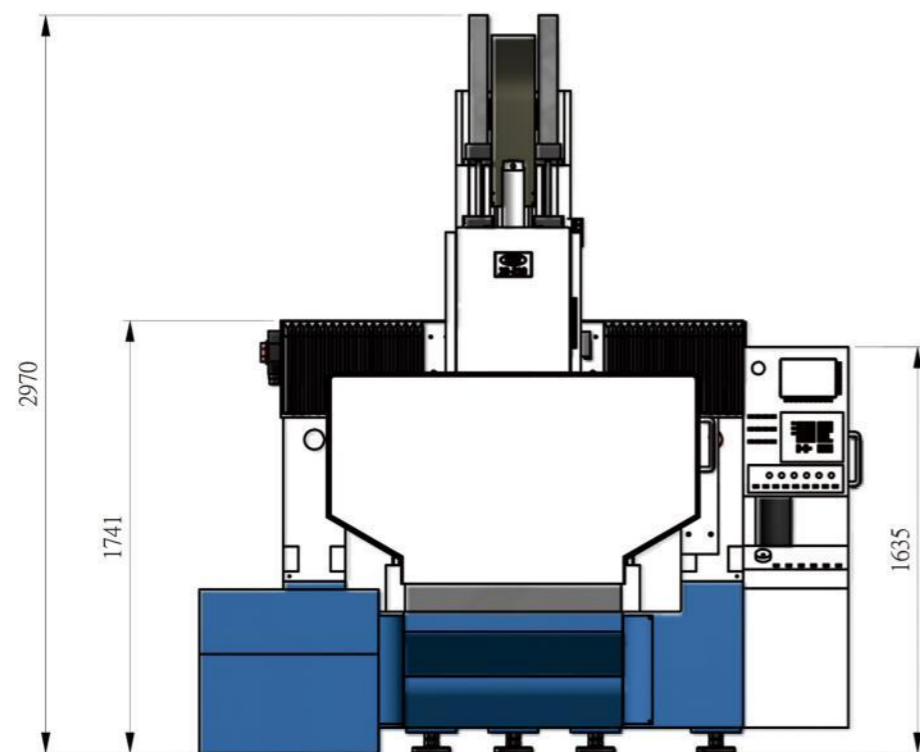
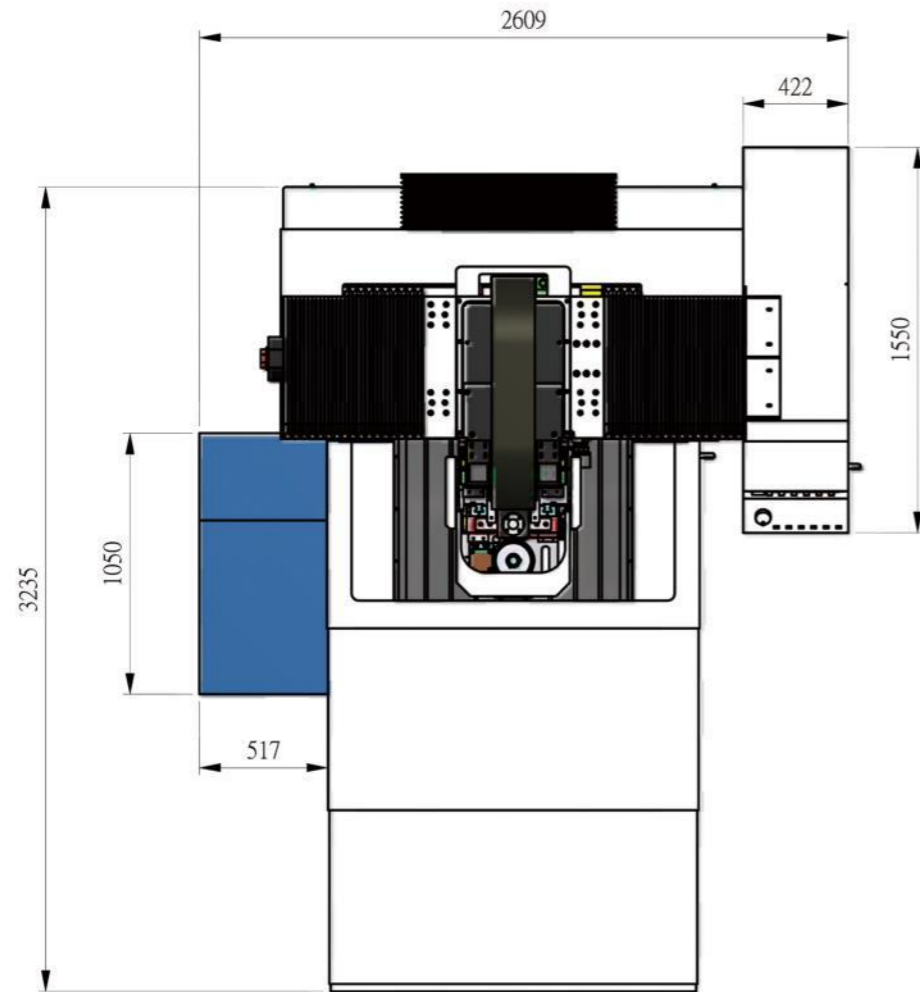

JG-510GC

External Dimension for Groove / Gear Grinding machine

內 / 外齒輪研磨機

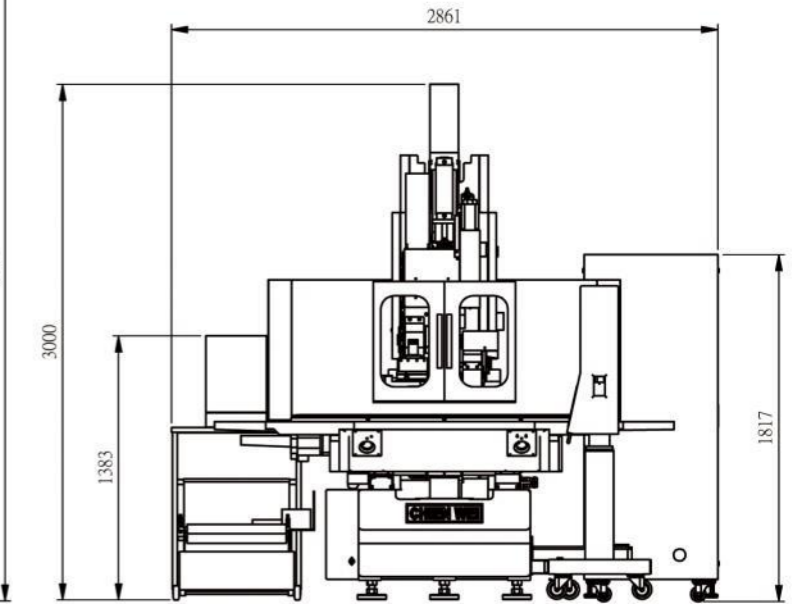
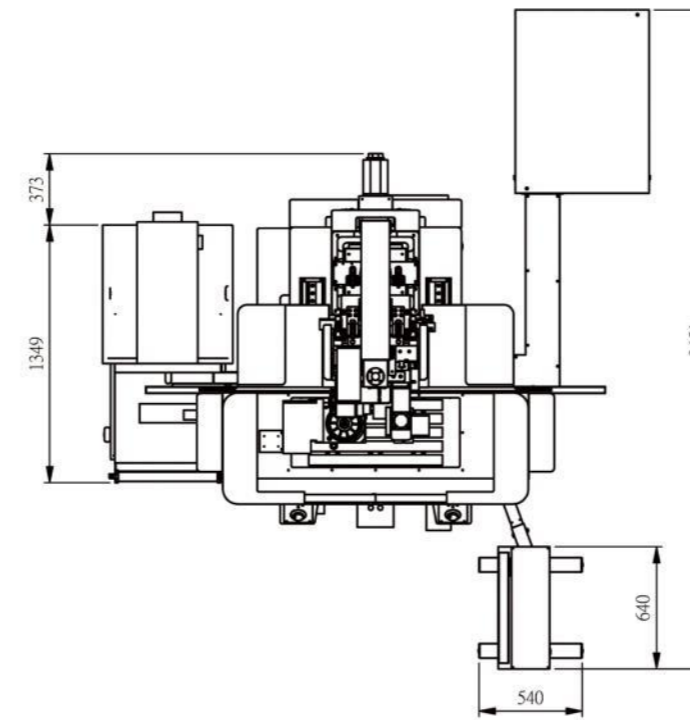
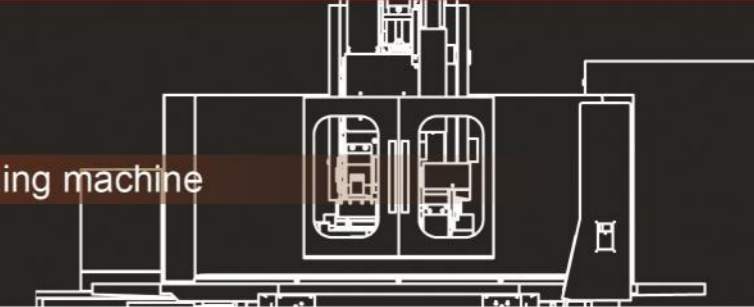

JG-510GC 外齒輪研磨機

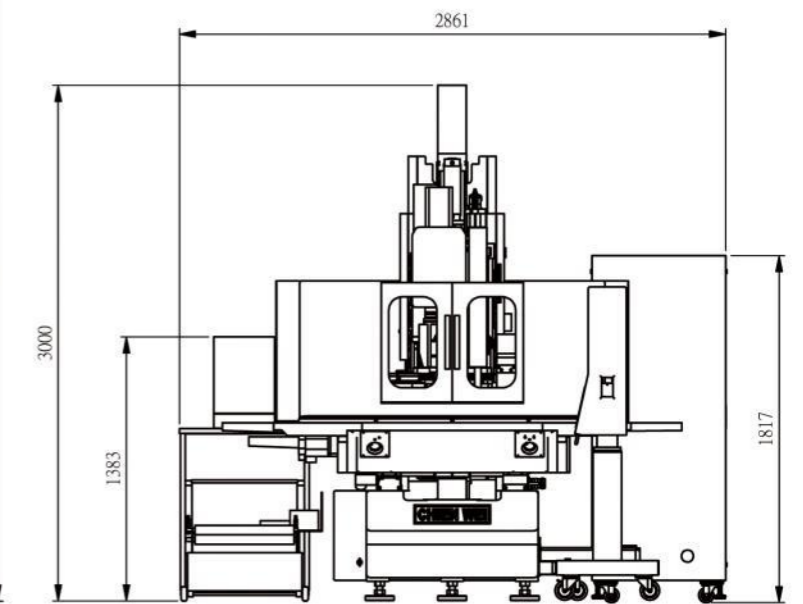
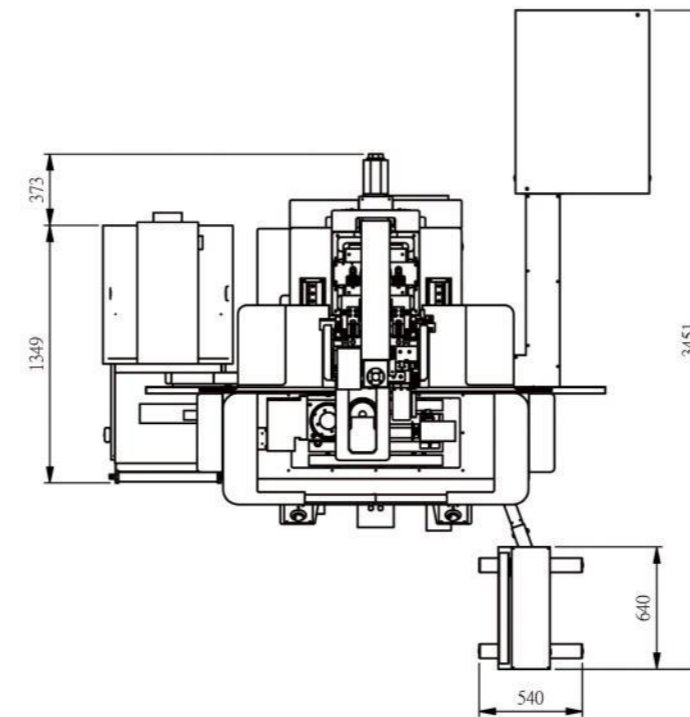

JG-510GC 內齒輪研磨機