

VKT Series

Yatay Vibrasyon Yüzey İşlem Makineleri Linear Vibratory Surface Finishing Machines



Ek Aksesuarlar

- Pnömatik Ses Kapağı
- Hız Kontrol
- Dozaj Pompası
- Manyetik Valf
- Elektrik Pano Standı
- Durulama Su Boru Sistemi

Additional Accesories:

- Pneumatic Sound Lid
- Frequency Control
- Dossage Pump
- Magnetic Valve
- Control Panel Base
- Rinsing Pipe

VKT serisi vibrasyon makineleri her türlü metal ve metal dışı malzemelerden mamül parçaların yüzey işlemlerinde kullanılır. Bu seri makineler genellikle uzun ve büyük hacimli parçalar için kullanılır.

VKT series machines can be used for surface finishing of metal and nonmetal work pieces. These type of machines generally used for too long and large volume surfaced work pieces.



VKTO Type Machine
VKTO Tip Makine

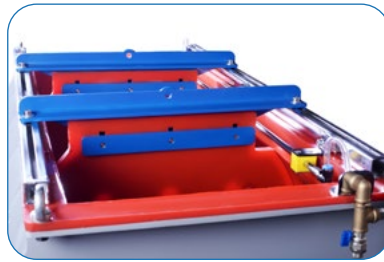

Rinsing Pipe
Durulama Hortumu



Electric Control Panel
Elektrik Panosu

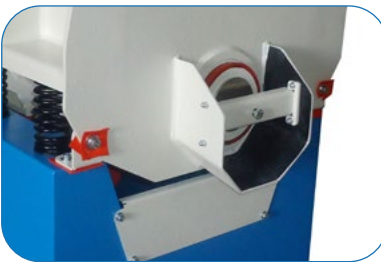

Media Unload Gate
Taş Tahliye Kapağı



Dirty Water Discharge Valve
Pis Su Tahliye Vanası

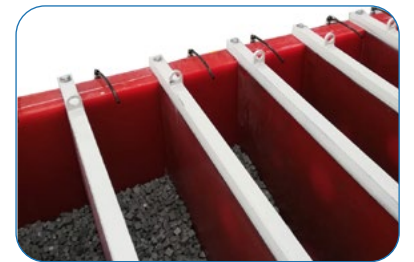

Divider
Ayrıcı Aparat

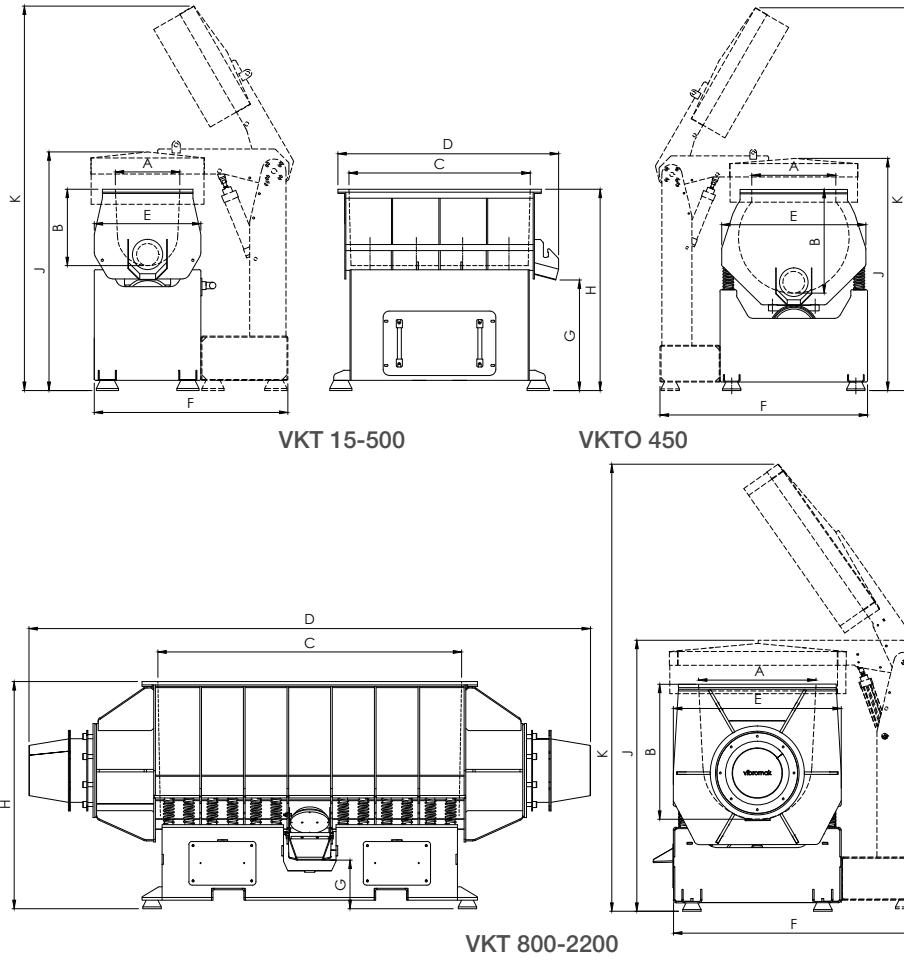

Teknik Ölçüler Technical Dimensions

TİP / TYPE		VKT 15	VKT 30	VKT 50	VKT 100	VKT 200	VKT 300	VKT 500	VKT 800	VKT 1000	VKT 1600	VKT 2200	VKTO 450
Brüt Hacim Gross Volume	Lt	16	32	49	96	204	305	502	792	1040	1596	2197	445
PU Kalınlığı PU Thickness	mm	15-20	15-20	15-20	15-25	15-25	15-25	15-25	15-25	15-25	15-25	20-30	15-25
Motor Gücü Engine Power	Kw / rpm	0,3	0,3	0,6	0,9	1,6	1,9	2,5	2 x 2,5	2 x 5	2 x 7	2 x 7	2,2
Gerilim Voltage	V/Hz	380/50	380/50	380/50	380/50	380/50	380/50	380/50	380/50	380/50	380/50	380/50	380/50
Çalışma Devri Operating Speed	rpm	1500	1500	1500	1500	1500	1500	1500	1500	1500	1500	1500	1500
Ağırlık Weight	Kg	70	100	150	240	390	540	800	1200	1800	2100	2600	640
A	mm	180	250	260	320	400	440	600	700	740	880	1000	500/660
B	mm	200	320	320	380	510	550	620	800	850	1000	1100	620
C	mm	500	590	740	900	1100	1340	1550	1600	1800	2000	2200	1310
D	mm	630	710	940	1100	1300	1560	1800	2930	3350	3550	3800	1520
E	mm	360	440	450	530	630	720	860	960	1000	1150	1250	860
F	mm	--	625	800	970	1060	1100	1290	1350	1460	1620	1720	1250
G	mm	500	500	550	550	450	450	500	300	300	350	300	510
H	mm	800	880	900	1000	1000	1100	1180	1250	1350	1500	1550	1200
J	mm	--	850	1120	1210	1220	1320	1400	1470	1600	1770	1820	1400
K	mm	--	1300	1650	1870	1960	2080	2230	2425	2600	2880	3020	2300

Tüm ölçüler milimetredir.
All dimensions are millimeters.