

KIZAKLI KOMBİNE BAĞLAMA PABUCU UYGULAMALARI

COMBINED SLIDING CLAMP APPLICATION

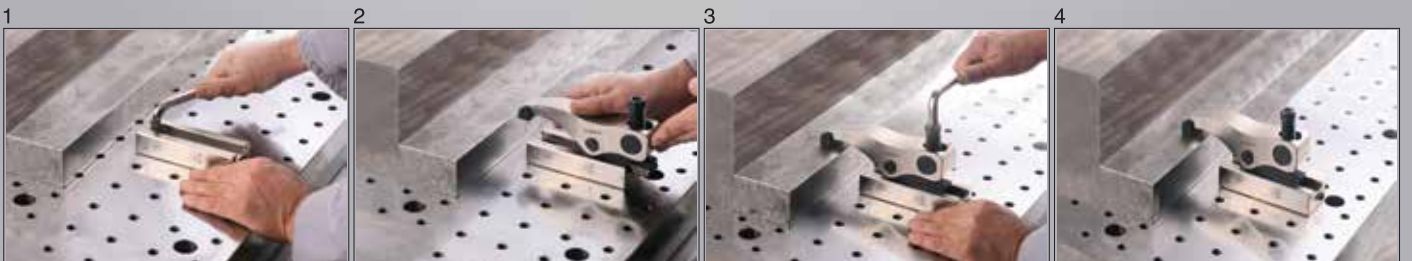

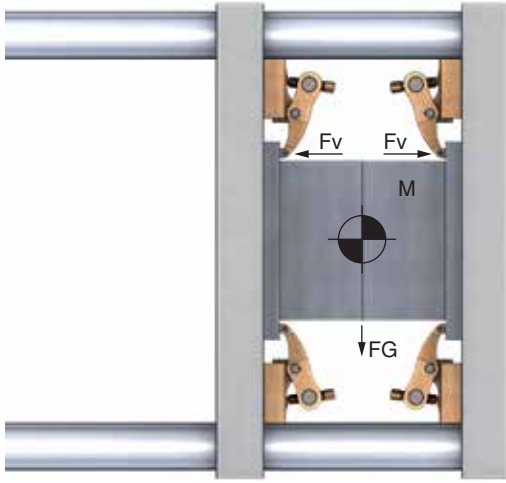

Enjeksiyon Kalıpları İçin Uygulama Örneği

Power Clamp For Injection Moulding

Hesaplama Formülü / Formula Calculator

$\frac{M \times FG}{1000} = \text{kN}$	$\frac{2500 \times 9.81}{1000} = 24.52 \text{ kN}$
$\frac{\text{kN}}{\mu} = \text{Sonuç / Result}$	$\frac{24.52}{0.14} = 175.14 \text{ kN}$
$\frac{\text{Sonuç}}{Fv} = \text{Bağlama Sayısı / Number of Clamp}$	$\frac{175.14 \text{ kN}}{25 \text{ kN}} = 7 \text{ Bağlama / Clamp}$ 8 adet kullanın 8 pcs Use

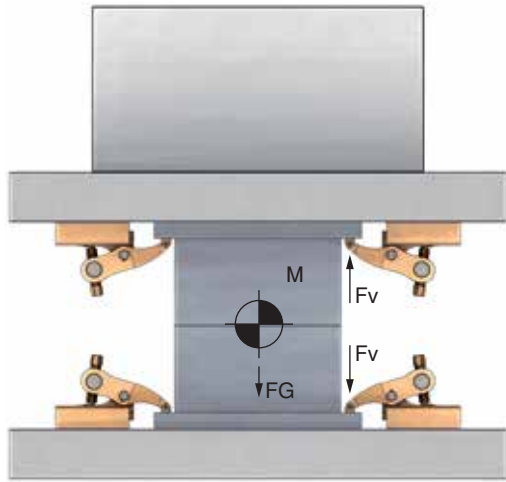

Pres Kalıpları İçin Uygulama Örneği

Power Clamp For Press Moulding

Hesaplama Formülü / Formula Calculator

$\frac{M \times FG}{1000} = \text{kN}$	$\frac{5000 \times 9.81}{1000} = 49.050 \text{ kN}$
$\frac{\text{kN}}{\mu} = \text{Sonuç / Result}$ <small>(Üst Kalıp %60) (Alt Kalıp % 40)</small>	$\frac{49.05}{0.14} = 350.35 \text{ kN}$ <small>(%60 Üst Kalıp= 210.21) (% 40 Alt Kalıp= 140.14)</small>
$\frac{\text{Sonuç}}{Fv} = \text{Bağlama Sayısı / Number of Clamp}$ <small>(Üst Kalıp)</small>	$\frac{210.21 \text{ kN}}{25 \text{ kN}} = 8 \text{ Bağlama Sayısı / 8 Number of Clamp}$
$\frac{\text{Sonuç}}{Fv} = \text{Bağlama Sayısı / Number of Clamp}$ <small>(Alt Kalıp)</small>	$\frac{140.14 \text{ kN}}{25 \text{ kN}} = 5.6 \text{ Bağlama / Clamp}$ 6 adet kullanın 6 pcs Use

K.K.S.P Kuvvet Diyagramı / Force Diagram

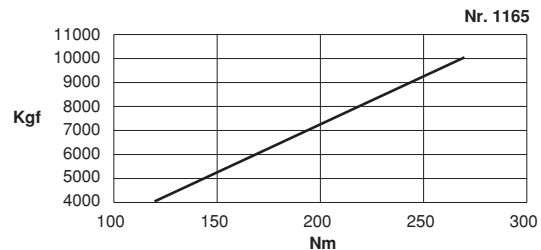
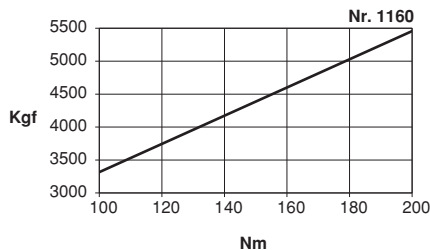
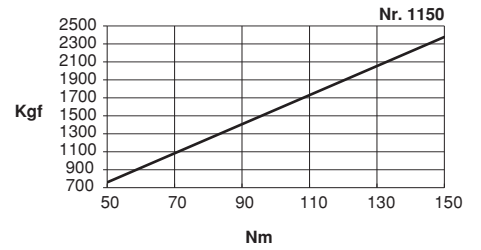
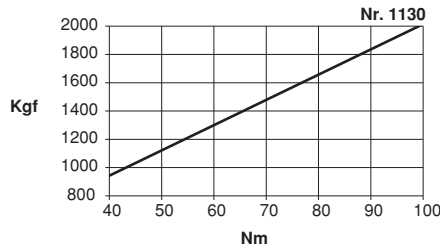
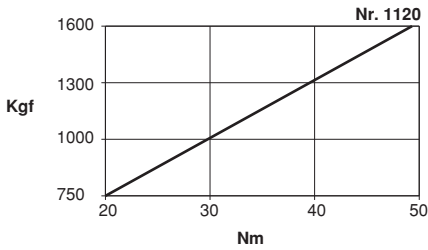

Referans Nr.	a	m	h		s	s1	e1	d	sw	L	e	b	c	Sıkma Kuvveti Clamping Force Kgf	Nm	g
			min	max												
1120-014 T	14	M12	0	50	12-66	25	100	M14	8	104	35.5	38	13	1600	50	1740
1120-016 T	16	M12	0	50	12-66	25	100	M14	8	104	35.5	38	13	1600	50	1755
1120-018 T	18	M12	0	50	12-66	25	100	M14	8	104	35.5	38	13	1600	50	1785
1120-014 LT	14	M12	0	50	12-81	25	100	M14	8	130	35.5	38	13	1600	50	1980
1120-016 LT	16	M12	0	50	12-81	25	100	M14	8	130	35.5	38	13	1600	50	1995
1120-018 LT	18	M12	0	50	12-81	25	100	M14	8	130	35.5	38	13	1600	50	2000

Ürün Nr. 1120-(T) Kızaklı Kombine Bağlama Pabucu

- (a) 14-18 T-Kanalda M12 imbus civata DIN 508 T-Pabuçla kullanılır.
- Parça yükseklik sıkma aralığı 0-50 mm.
- İleri-geri hareket mesafesi 54mm'dir. Sıkma Kuvveti 1600 kgf.

Ürün Nr. 1120-(LT) Kızaklı Kombine Bağlama Pabucu

- (a) 14-18 T-Kanalda M12 imbus civata DIN 508 T-Pabuçla kullanılır.
- Parça yükseklik sıkma aralığı 0-50 mm.
- İleri-geri hareket mesafesi 69mm'dir. Sıkma Kuvveti 1600 kgf.

Product Nr. 1120-(T) Combined Sliding Clamp

- (a) 14-18 is used in T-Slot and M12 imbus bolt is used with DIN 508 T-Nut.
- Height clamping gap of the piece is 0-50mm
- Back and forth movement distance is 54mm. Clamping force is 1600 kgf.

Product Nr. 1120-(LT) Combined Sliding Clamp

- (a) 14-18 is used in T-Slot and M12 imbus bolt is used with DIN 508 T-Nut.
- Height clamping gap of the piece is 0-50mm
- Back and forth movement distance is 69mm. Clamping force is 1600 kgf.

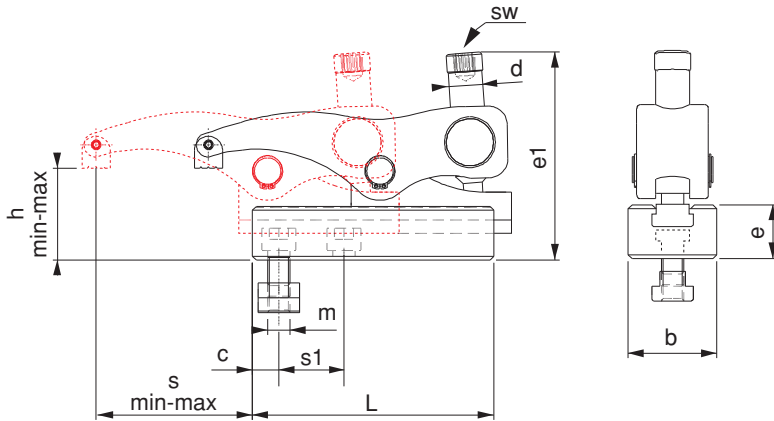

UYGULAMA;

- 1- Alt kızağı iş parçasına uygun şekle getir sabitle
- 2- Üst gövdeyi kızağa sür, istenilen pozisyona getir
- 3- Pabuç imbus civatasıyla iş parçasını sabitle
- 4- Parça işlenmek için hazır

APPLICATION;

- 1- Slide cradle is brought to suitable form with the work piece and then it is fixed
- 2- Upper body is driven to the slide and it is brought to desired position
- 3- Work piece is fixed with the imbus bolt of the clamp
- 4- Then the work piece becomes ready to be machined.

Kullanım Alanı

Enjeksiyon makineleri presler, freze tezgahları, matkap tezgahları ve çeşitli sanayi makineleri

Area of Use

Injection Machines, Presses, Milling Machines, Drilling Machines and various Industrial Machines



Referans Nr.	a	m	h		s	s1	e1	d	sw	L	e	b	c	Sıkma Kuvveti Clamping Force Kgf	Nm	 (g)
			min	max												
1130-014 T	14	M12	0	60	15-83	30	113	M18	10	130	39	48	17,5	2000	100	3040
1130-016 T	16	M12	0	60	15-83	30	113	M18	10	130	39	48	17,5	2000	100	3055
1130-018 T	18	M12	0	60	15-83	30	113	M18	10	130	39	48	17,5	2000	100	3085
1130-020 T	20	M12	0	60	15-83	30	113	M18	10	130	39	48	17,5	2000	100	3135
1130-022 T	22	M12	0	60	15-83	30	113	M18	10	130	39	48	17,5	2000	100	3150
1130-014 LT	14	M12	0	60	15-107	30	113	M18	10	170	39	48	17,5	2000	100	3820
1130-016 LT	16	M12	0	60	15-107	30	113	M18	10	170	39	48	17,5	2000	100	3835
1130-018 LT	18	M12	0	60	15-107	30	113	M18	10	170	39	48	17,5	2000	100	3865
1130-020 LT	20	M12	0	60	15-107	30	113	M18	10	170	39	48	17,5	2000	100	3915
1130-022 LT	22	M12	0	60	15-107	30	113	M18	10	170	39	48	17,5	2000	100	3930

Ürün Nr. 1130-(T) Kızaklı Kombine Bağlama Pabucu

- (a) 14-22 T-Kanalda M12 imbus civata DIN 508 T-Pabuçla kullanılır.
- Parça yükseklik sıkma aralığı 0-60 mm.
- İleri-geri hareket mesafesi 68mm'dir. Sıkma Kuvveti 2000 kgf.

Ürün Nr. 1130-(LT) Kızaklı Kombine Bağlama Pabucu

- (a) 14-22 T-Kanalda M12 imbus civata DIN 508 T-Pabuçla kullanılır.
- Parça yükseklik sıkma aralığı 0-60 mm.
- İleri-geri hareket mesafesi 92mm'dir. Sıkma Kuvveti 2000 kgf.

Product Nr. 1130-(T) Combined Sliding Clamp

- (a) 14-22 is used in T-Slot and M12 imbus bolt is used with DIN 508 T-Nut.
- Height clamping gap of the piece is 0-60mm.
- Back and forth movement distance is 68mm. Clamping force is 2000 kgf.

Product Nr. 1130-(LT) Combined Sliding Clamp

- (a) 14-22 is used in T-Slot and M12 imbus bolt is used with DIN 508 T-Nut.
- Height clamping gap of the piece is 0-60mm.
- Back and forth movement distance is 92mm. Clamping force is 2000 kgf.

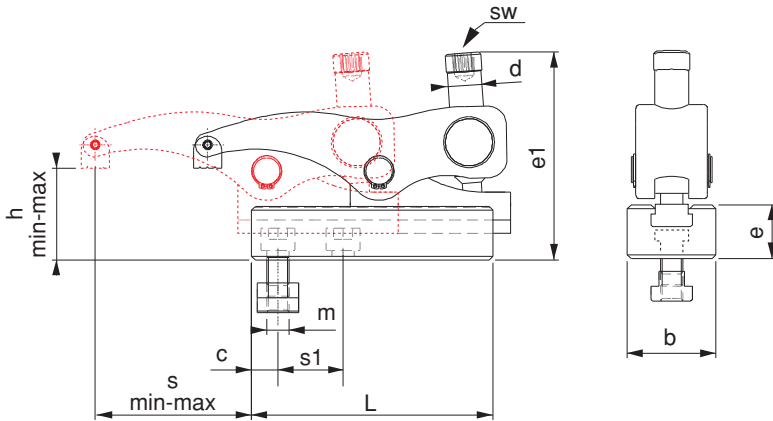
UYGULAMA;

- 1- Alt kızıağı iş parçasına uygun şekle getir sabitle
- 2- Üst gövdeyi kızıağa sür, istenilen pozisyona getir
- 3- Pabuç imbus civatasıyla iş parçasını sabitle
- 4- Parça işlenmek için hazır

APPLICATION;

- 1- Slide cradle is brought to suitable form with the work piece and then it is fixed
- 2- Upper body is driven to the slide and it is brought to desired position
- 3- Work piece is fixed with the imbus bolt of the clamp
- 4- Then the work piece becomes ready to be machined.

Kullanım Alanı

Enjeksiyon makineleri presler, freze tezgahları, matkap tezgahları ve çeşitli sanayi makineleri

Area of Use

Injection Machines, Presses, Milling Machines, Drilling Machines and various Industrial Machines

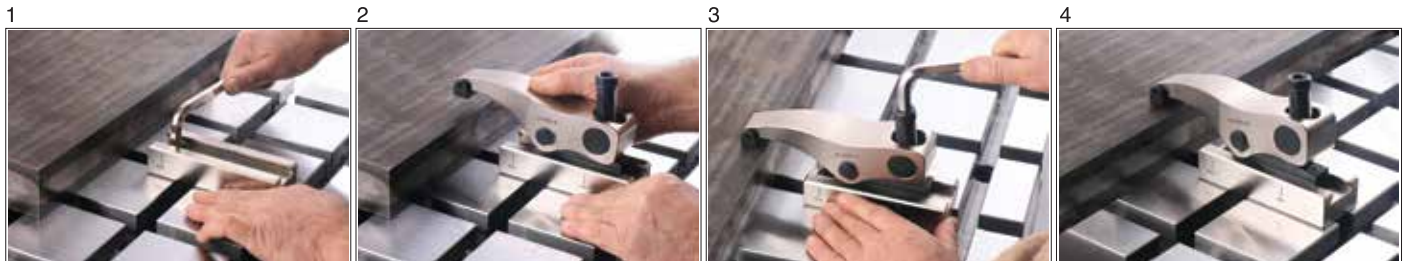

Referans Nr.	a	m	h		s	s1	e1	d	sw	L	e	b	c	Sıkma Kuvveti Clamping Force Kgf	Nm	 (g)
			min	max												
1150-118 T	18	M16	0	65	18-96	35	125	M20	12	140	43	55	19,5	2500	150	4410
1150-120 T	20	M16	0	65	18-96	35	125	M20	12	140	43	55	19,5	2500	150	4460
1150-122 T	22	M16	0	65	18-96	35	125	M20	12	140	43	55	19,5	2500	150	4515
1150-124 T	24	M16	0	65	18-96	35	125	M20	12	140	43	55	19,5	2500	150	4615
1150-128 T	28	M16	0	65	18-96	35	125	M20	12	140	43	55	19,5	2500	150	4715
1150-118 LT	18	M16	0	65	18-128	35	125	M20	12	200	43	55	19,5	2500	150	5770
1150-120 LT	20	M16	0	65	18-128	35	125	M20	12	200	43	55	19,5	2500	150	5830
1150-122 LT	22	M16	0	65	18-128	35	125	M20	12	200	43	55	19,5	2500	150	5885
1150-124 LT	24	M16	0	65	18-128	35	125	M20	12	200	43	55	19,5	2500	150	5985
1150-128 LT	28	M16	0	65	18-128	35	125	M20	12	200	43	55	19,5	2500	150	6000

Ürün Nr. 1150-(T) Kızaklı Kombine Bağlama Pabucu

- (a) 18-28 T-Kanalda M16 imbus civata DIN 508 T-Pabuçla kullanılır.
- Parça yükseklik sıkma aralığı 0-65mm.
- İleri-geri hareket mesafesi 78mm'dir. Sıkma Kuvveti 2500 kgf.

Ürün Nr. 1150-(LT) Kızaklı Kombine Bağlama Pabucu

- (a) 18-28 T-Kanalda M16 imbus civata DIN 508 T-Pabuçla kullanılır.
- Parça yükseklik sıkma aralığı 0-65mm.
- İleri-geri hareket mesafesi 110mm'dir. Sıkma Kuvveti 2500 kgf.

Product Nr. 1150-(T) Combined Sliding Clamp

- (a) 18-28 is used in T-Slot and M16 imbus bolt is used with DIN 508 T-Nut.
- Height clamping gap of the piece is 0-65mm.
- Back and forth movement distance is 78mm. Clamping force is 2500 kgf.

Product Nr. 1150-(LT) Combined Sliding Clamp

- (a) 18-28 is used in T-Slot and M16 imbus bolt is used with DIN 508 T-Nut.
- Height clamping gap of the piece is 0-65mm.
- Back and forth movement distance is 110mm. Clamping force is 2500 kgf.

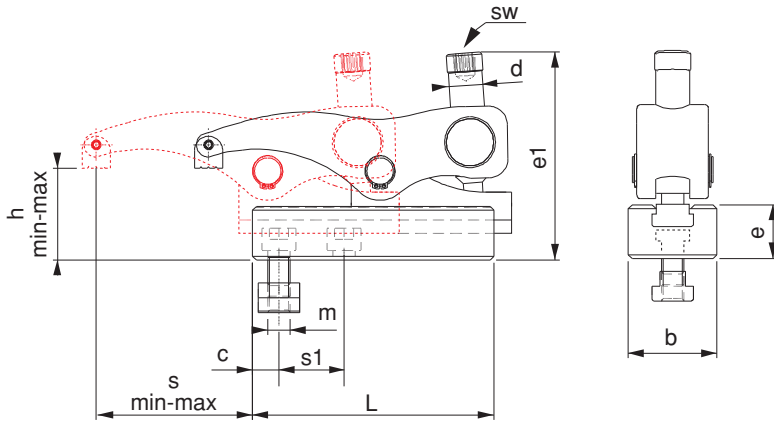
UYGULAMA;

- 1- Alt kızıağı iş parçasına uygun şekle getir sabitle
- 2- Üst gövdeyi kızıağa sür, istenilen pozisyona getir
- 3- Pabuç imbus civatasıyla iş parçasını sabitle
- 4- Parça işlenmek için hazır

APPLICATION;

- 1- Slide cradle is brought to suitable form with the work piece and then it is fixed
- 2- Upper body is driven to the slide and it is brought to desired position
- 3- Work piece is fixed with the imbus bolt of the clamp
- 4- Then the work piece becomes ready to be machined.

Kullanım Alanı

Enjeksiyon makineleri presler, freze tezgahları, matkap tezgahları ve çeşitli sanayi makineleri

Area of Use

Injection Machines, Presses, Milling Machines, Drilling Machines and various Industrial Machines

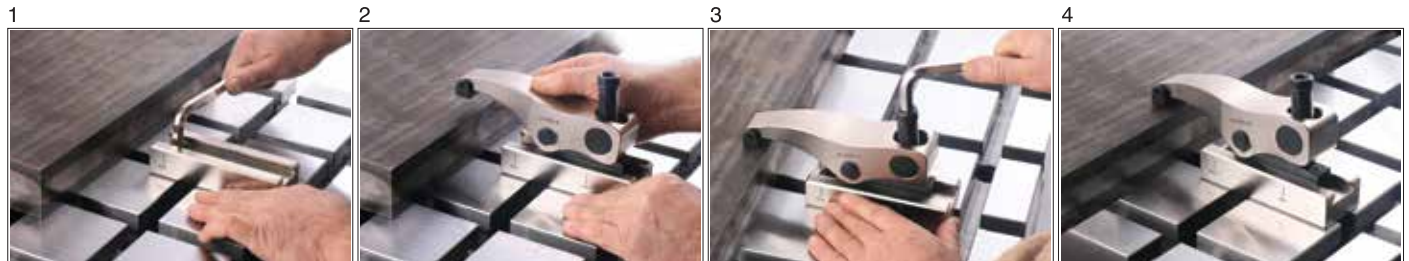

Referans Nr.	a	m	h		s	s1	e1	d	SW		L	e	b	c	Sıkma Kuvveti Clamping Force Kgf	Nm	g
			min	max													
1160-222 T	22	M20	20	80	17-92	41.5	175	M24	12	24	178	55	74	24	5500	200	9030
1160-224 T	24	M20	20	80	17-92	41.5	175	M24	12	24	178	55	74	24	5500	200	9120
1160-228 T	28	M24	20	80	17-92	41.5	175	M24	12	24	178	55	74	24	5500	200	9180
1160-236 T	36	M24	20	80	17-92	41.5	175	M24	12	24	178	55	74	24	5500	200	9600
1160-222 LT	22	M20	20	80	25-148	41.5	175	M24	12	24	256	55	74	24	5500	280	12110
1160-224 LT	24	M20	20	80	25-148	41.5	175	M24	12	24	256	55	74	24	5500	280	12210
1160-228 LT	28	M24	20	80	25-148	41.5	175	M24	12	24	256	55	74	24	5500	280	12270
1160-236 LT	36	M24	20	80	25-148	41.5	175	M24	12	24	256	55	74	24	5500	280	12310
1165-222 T	22	M20	30	80	34-92	41.5	194	M24	12	24	205	55	85	24	10000	270	11820
1165-224 T	24	M20	30	80	34-92	41.5	194	M24	12	24	205	55	85	24	10000	270	11900
1165-228 T	28	M24	30	80	34-92	41.5	194	M24	12	24	205	55	85	24	10000	270	11960
1165-236 T	36	M24	30	80	34-92	41.5	194	M24	12	24	205	55	85	24	10000	270	12000

Ürün Nr. 1160-(T) Kızaklı Kombine Bağlama Pabucu

- (a) 22-36 T-Kanalda M20-M24 imbus civata DIN 508 T-Pabuçla kullanılır.
- Parça yükseklik sıkma aralığı 20-80mm.
- İleri-geri hareket mesafesi 75mm'dir. Sıkma Kuvveti 5500 kgf.

Ürün Nr. 1160-(LT) Kızaklı Kombine Bağlama Pabucu

- (a) 22-36 T-Kanalda M20-M24 imbus civata DIN 508 T-Pabuçla kullanılır.
- Parça yükseklik sıkma aralığı 20-80mm.
- İleri-geri hareket mesafesi 123mm'dir. Sıkma Kuvveti 5500 kgf.

Ürün Nr. 1165-(T) Kızaklı Kombine Bağlama Pabucu

- (a) 22-36 T-Kanalda M20-M24 imbus civata DIN 508 T-Pabuçla kullanılır.
- Parça yükseklik sıkma aralığı 30-80mm.
- İleri-geri hareket mesafesi 58mm'dir. Sıkma Kuvveti 10000 kgf.

Product Nr. 1160-(T) Combined Sliding Clamp

- (a) 22-36 is used in T-Slot and M20-M24 imbus bolt is used with DIN 508 T-Nut.
- Height clamping gap of the piece is 20-80mm.
- Back and forth movement distance is 75mm. Clamping force is 5500 kgf.

Product Nr. 1160-(LT) Combined Sliding Clamp

- (a) 22-36 is used in T-Slot and M20-M24 imbus bolt is used with DIN 508 T-Nut.
- Height clamping gap of the piece is 20-80mm.
- Back and forth movement distance is 123mm. Clamping force is 5500 kgf.

Product Nr. 1165-(T) Combined Sliding Clamp

- (a) 22-36 is used in T-Slot and M20-M24 imbus bolt is used with DIN 508 T-Nut.
- Height clamping gap of the piece is 30-80mm.
- Back and forth movement distance is 58mm. Clamping force is 10000 kgf.

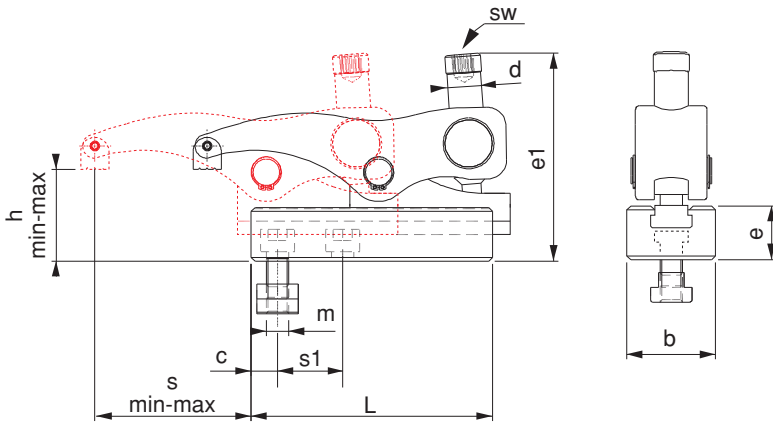
UYGULAMA;

- 1- Alt kızıağı iş parçasına uygun şekle getir sabitle
- 2- Üst gövdeyi kızıağa sür, istenilen pozisyona getir
- 3- Pabuç imbus civatasıyla iş parçasını sabitle
- 4- Parça işlenmek için hazır

APPLICATION;

- 1- Slide cradle is brought to suitable form with the work piece and then it is fixed
- 2- Upper body is driven to the slide and it is brought to desired position
- 3- Work piece is fixed with the imbus bolt of the clamp
- 4- Then the work piece becomes ready to be machined.



Kullanım Alanı

Enjeksiyon makineleri presler, freze tezgahları, matkap tezgahları ve çeşitli sanayi makineleri

Area of Use

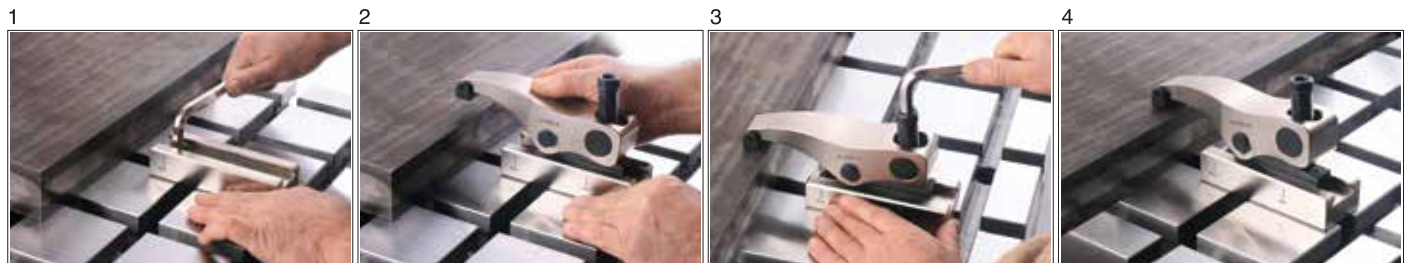
Injection Machines, Presses, Milling Machines, Drilling Machines and various Industrial Machines



Referans Nr.		h		s	s1	e1	d	sw	L	e	b	c	k	Sıkma Kuvveti Clamping Force Kgf	Nm	
		min	max													
1120-010 M	M10	0	50	12-66	25	100	M14	8	104	35.5	38	13	20	1600	50	1740
1120-012 M	M12	0	0	12-66	25	100	M14	8	104	35.5	38	13	20	1600	50	1755
1120-010 LM	M10	0	50	12-81	25	100	M14	8	130	35.5	38	13	20	1600	50	1980
1120-012 LM	M12	0	50	12-81	25	100	M14	8	130	35.5	38	13	20	1600	50	1995

Ürün Nr. 1120-(M) Kızaklı Kombine Bağlama Pabucu

- M10-M12 diş deliklerde (1120-310)-(1120-312) Referans Nr. imbus civatayla kullanılır.
- Parça yükseklik sıkma aralığı 0-50 mm.
- İleri-geri hareket mesafesi 54mm'dir. Sıkma Kuvveti 1600 kgf.

Ürün Nr.1120-(LM) Kızaklı Kombine Bağlama Pabucu

- M10-M12 diş deliklerde (1120-310)-(1120-312) Referans Nr. imbus civatayla kullanılır.
- Parça yükseklik sıkma aralığı 0-50 mm.
- İleri-geri hareket mesafesi 69mm'dir. Sıkma Kuvveti 1600 kgf.

Product Nr. 1120-(M) Combined Sliding Clamp

- In the outer holes M10-M12 are used with the Reference Nr. imbus bolt (1120-310)-(1120-312)
- Height clamping gap of the piece is 0-50mm.
- Back and forth movement distance is 54mm. Clamping force is 1600 kgf.

Product Nr.1120-(LM) Combined Sliding Clamp

- In the outer holes M10-M12 are used with the Reference Nr. imbus bolt (1120-310)-(1120-312)
- Height clamping gap of the piece is 0-50mm.
- Back and forth movement distance is 69mm. Clamping force is 1600 kgf.

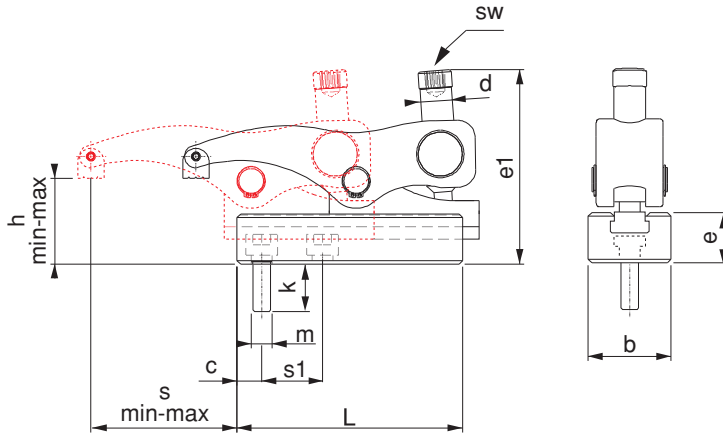

1120-... M



1120-... LM



AVANTAJLARI;

- 1600 kgf - 2000 kgf sıkma kuvveti
- Delik ve T-Kanalda kullanım
- Kızak üzerinde kaydırarak değişik pozisyonlarda sabitleme
- imbus civatasıyla desteksiz yüksek ve düşük mesafeleri sıkır
- Pratik yapısından dolayı hızlı ve kolay şekilde bağlama sağlar

ADVANTAGES

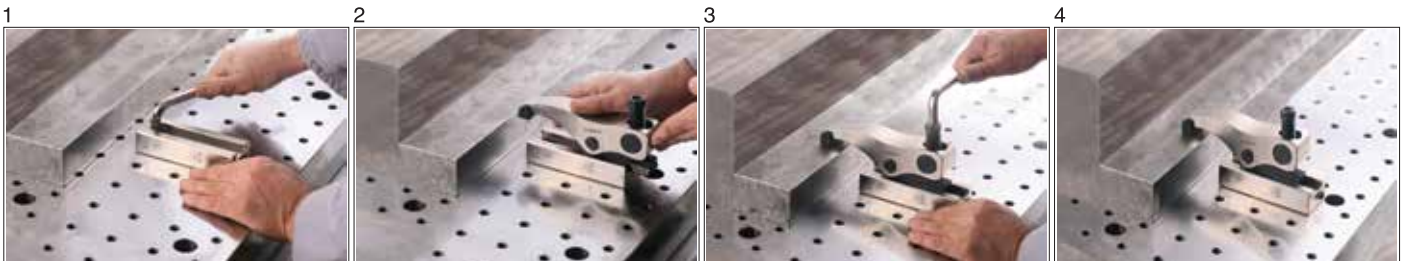
- 1600 kgf - 2000 kgf Clamping Force.
- Usings in the hole and T-Slot.
- Ability to be fixed in verious positions by sliding on the slide.
- It clamps high and low distances without support with the imbus bolt.
- It provides rapid and easy connection due to it's practical structure.



Referans Nr.		h		s	s1	e1	d	sw	L	e	b	c	k	Sıkma Kuvveti Clamping Force Kgf	Nm	
		min	max													
1130-012 M	M12	0	60	15-83	30	113	M18	10	130	39	48	17,5	22	2000	100	3040
1130-016 M	M16	0	60	15-83	30	113	M18	10	130	39	48	17,5	26	2000	100	3055
1130-012 LM	M12	0	60	15-107	30	113	M18	10	170	39	48	17,5	22	2000	100	3820
1130-016 LM	M16	0	60	15-107	30	113	M18	10	170	39	48	17,5	26	2000	100	3835

Ürün Nr. 1130-(M) Kızaklı Kombine Bağlama Pabucu

- M12-M16 dış deliklerde (1130-412)-(1130-416) Referans Nr. imbus civatayla kullanılır.
- Parça yükseklik sıkma aralığı 0-60 mm.
- İleri-geri hareket mesafesi 68mm'dir. Sıkma Kuvveti 2000 kgf.

Ürün Nr. 1130-(LM) Kızaklı Kombine Bağlama Pabucu

- M12-M16 dış deliklerde (1130-412)-(1130-416) Referans Nr. imbus civatayla kullanılır.
- Parça yükseklik sıkma aralığı 0-60 mm.
- İleri-geri hareket mesafesi 92mm'dir. Sıkma Kuvveti 2000 kgf.

Product Nr. 1130-(M) Combined Sliding Clamp

- In the outer holes M12-M16 are used with the Reference Nr. imbus bolt (1130-412)-(1130-416)
- Height clamping gap of the piece is 0-60mm.
- Back and forth movement distance is 68mm. Clamping force is 2000 kgf.

Product Nr. 1130-(LM) Combined Sliding Clamp

- In the outer holes M12-M16 are used with the Reference Nr. imbus bolt (1130-412)-(1130-416)
- Height clamping gap of the piece is 0-60mm.
- Back and forth movement distance is 92mm. Clamping force is 2000 kgf.

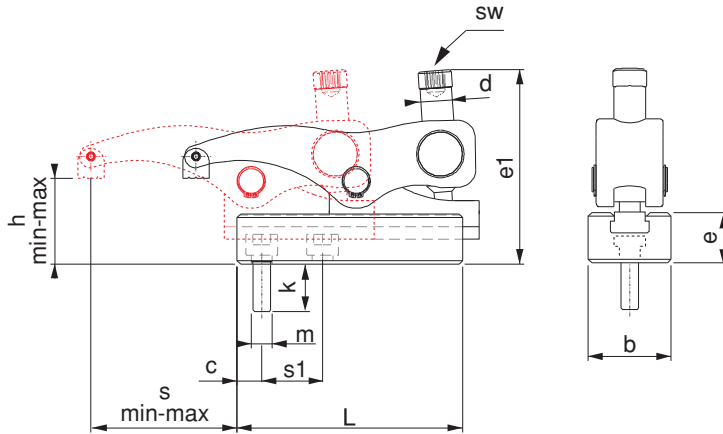

AVANTAJLARI;

- 1600 kgf - 2000 kgf sıkma kuvveti
- Delik ve T-Kanalda kullanım
- Kızak üzerinde kaydırarak değişik pozisyonlarda sabitleme
- imbus civatasıyla desteksiz yüksek ve düşük mesafeleri sıkar
- Pratik yapısından dolayı hızlı ve kolay şekilde bağlama sağlar

ADVANTAGES

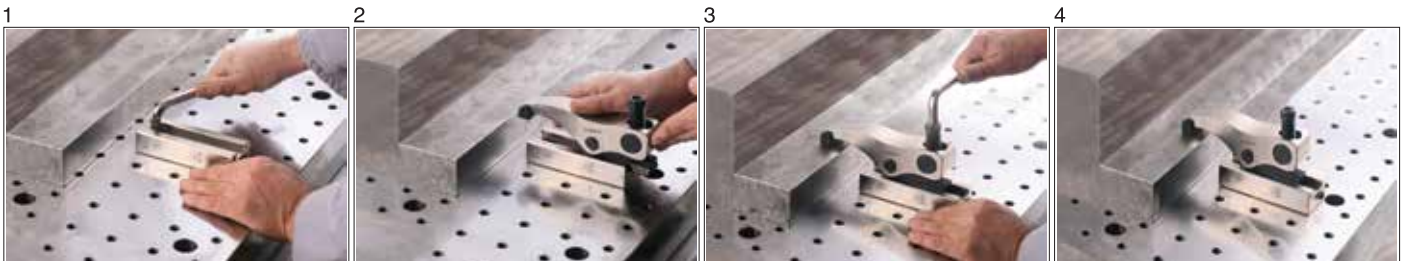
- 1600 kgf - 2000 kgf Clamping Force.
- Usings in the hole and T-Slot.
- Ability to be fixed in verious positions by sliding on the slide.
- It clamps high and low distances without support with the imbus bolt.
- It provides rapid and easy connection due to it's practical structure.



Referans Nr.		h		s	s1	e1	d	sw	L	e	b	c	k	Sıkma Kuvveti Clamping Force Kgf	Nm	
		min	max													
1150-116 M	M16	0	65	18-96	35	125	M20	12	140	43	55	19.5	26	2500	150	4340
1150-118 M	M18	0	65	18-96	35	125	M20	12	140	43	55	19.5	30	2500	150	4360
1150-120 M	M20	0	65	18-96	35	125	M20	12	140	43	55	19.5	30	2500	150	4370
1150-116 LM	M16	0	65	18-128	35	125	M20	12	200	43	55	19.5	26	2500	150	5770
1150-118 LM	M18	0	65	18-128	35	125	M20	12	200	43	55	19.5	30	2500	150	5830
1150-120 LM	M20	0	65	18-128	35	125	M20	12	200	43	55	19.5	30	2500	150	5885

Ürün Nr. 1150-(M) Kızaklı Kombine Bağlama Pabucu

- M16-M18-M20 diş deliklerde (1150-516)-(1150-518)-(1160-520) Referans Nr. imbus civatayla kullanılır.
- Parça yükseklik sıkma aralığı 0-65mm.
- İleri-geri hareket mesafesi 78mm'dir. Sıkma Kuvveti 2500 kgf.

Ürün Nr. 1150-(LM) Kızaklı Kombine Bağlama Pabucu

- M16-M18-M20 diş deliklerde (1150-516)-(1150-518)-(1160-520) Referans Nr. imbus civatayla kullanılır.
- Parça yükseklik sıkma aralığı 0-65mm.
- İleri-geri hareket mesafesi 110mm'dir. Sıkma Kuvveti 2500 kgf.

Product Nr. 1150-(M) Combined Sliding Clamp

- In the outer holes M16-M18-M20 are used with the Reference Nr. imbus bolt (1150-516)-(1150-518)-(1150-520).
- Height clamping gap of the piece is 0-65mm.
- Back and forth movement distance is 78mm. Clamping force is 2500 kgf.

Product Nr. 1150-(LM) Combined Sliding Clamp

- In the outer holes M16-M18-M20 are used with the Reference Nr. imbus bolt (1150-516)-(1150-518)-(1150-520).
- Height clamping gap of the piece is 0-65mm.
- Back and forth movement distance is 110mm. Clamping force is 2500 kgf.

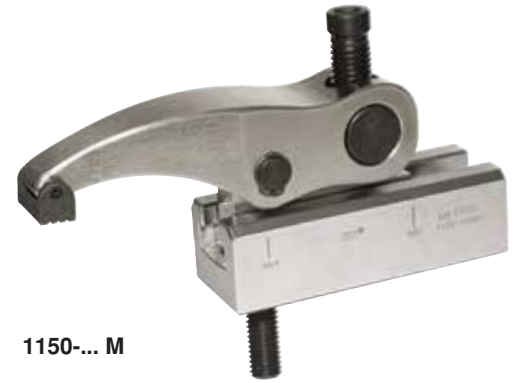
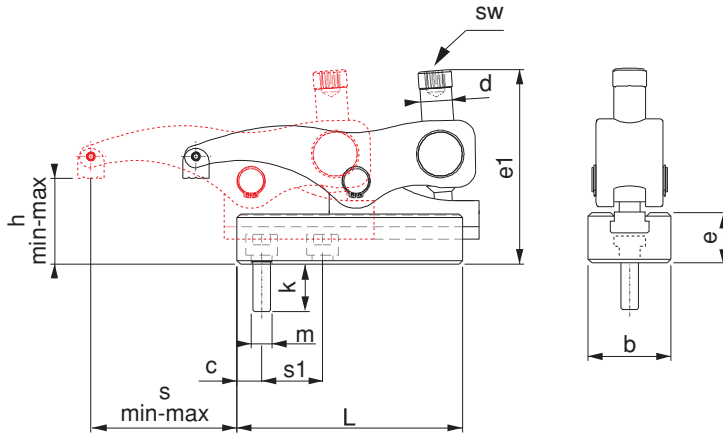

AVANTAJLARI;

- 1600 kgf - 2000 kgf sıkma kuvveti
- Delik ve T-Kanalda kullanım
- Kızak üzerinde kaydırarak değişik pozisyonlarda sabitleme
- imbus civatasıyla desteksiz yüksek ve düşük mesafeleri sıkar
- Pratik yapısından dolayı hızlı ve kolay şekilde bağlama sağlar

ADVANTAGES

- 1600 kgf - 2000 kgf Clamping Force.
- Usings in the hole and T-Slot.
- Ability to be fixed in various positions by sliding on the slide.
- It clamps high and low distances without support with the imbus bolt.
- It provides rapid and easy connection due to its practical structure.

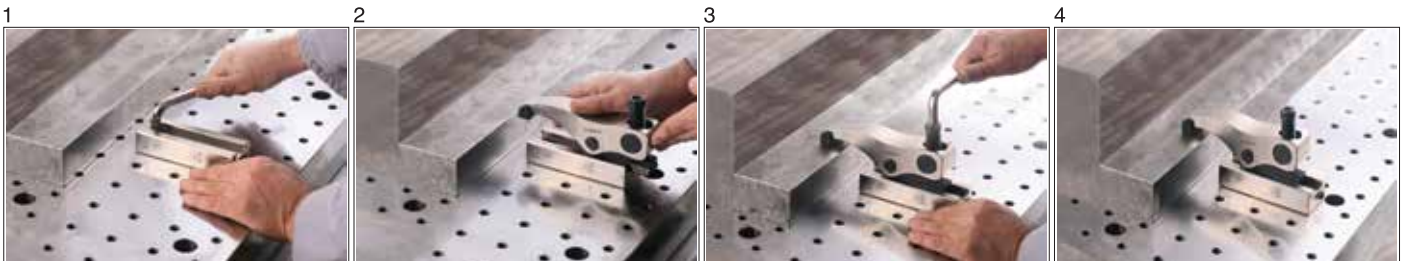

Referans Nr.	m	h		s	s1	e1	d	SW		L	e	b	c	k	Sıkma Kuvveti Clamping Force Kgf	Nm	(g)
		min	max														
1160-220 M	M20	20	80	17-92	41.5	175	M24	12	24	178	55	74	24	34	5500	200	8880
1160-222 M	M22	20	80	17-92	41.5	175	M24	12	24	178	55	74	24	38	5500	200	8900
1160-224 M	M24	20	80	17-92	41.5	175	M24	12	24	178	55	74	24	44	5500	200	8920
1160-230 M	M30*	20	80	17-92	41.5	175	M24	12	24	178	55	74	24	51	5500	200	9110
1160-220 LM	M20	20	80	25-148	41.5	175	M24	12	24	256	55	74	24	34	5500	280	12110
1160-222 LM	M22	20	80	25-148	41.5	175	M24	12	24	256	55	74	24	38	5500	280	12210
1160-224 LM	M24	20	80	25-148	41.5	175	M24	12	24	256	55	74	24	44	5500	280	12270
1160-230 LM	M30*	20	80	25-148	41.5	175	M24	12	24	256	55	74	24	51	5500	280	12310
1165-220 M	M20	30	80	34-92	41.5	215	M24	12	24	205	55	85	24	34	10000	270	11820
1165-222 M	M22	30	80	34-92	41.5	215	M24	12	24	205	55	85	24	38	10000	270	11900
1165-224 M	M24	30	80	34-92	41.5	215	M24	12	24	205	55	85	24	44	10000	270	11960
1165-230 M	M30*	30	80	34-92	41.5	215	M24	12	24	205	55	85	24	51	10000	270	12000

Ürün Nr. 1160-(M) Kızaklı Kombine Bağlama Pabucu

- M20-M22-M24-M30 diş deliklerde(1160-620)-(1160-622) (1160-624)-(1160-724)-(1160-730) Referans Nr. imbus civatayla kullanılır.
- Parça yükseklik sıkma aralığı 20-80mm.
- İleri-geri hareket mesafesi 75mm'dir. Sıkma Kuvveti 5500 kgf.

Ürün Nr. 1160-(LM) Kızaklı Kombine Bağlama Pabucu

- M20-M22-M24-M30 diş deliklerde(1160-620)-(1160-622) (1160-624)-(1160-724)-(1160-730) Referans Nr. imbus civatayla kullanılır.
- Parça yükseklik sıkma aralığı 20-80mm.
- İleri-geri hareket mesafesi 123mm'dir. Sıkma Kuvveti 5500 kgf.

Ürün Nr. 1165-(M) Kızaklı Kombine Bağlama Pabucu

- M20-M22-M24-M30 diş deliklerde(1160-620)-(1160-622) (1160-624)-(1160-724)-(1160-730) Referans Nr. imbus civatayla kullanılır.
- Parça yükseklik sıkma aralığı 30-80mm.
- İleri-geri hareket mesafesi 58mm'dir. Sıkma Kuvveti 10000 kgf.

Not: Nr.1160-230M - Nr.1165-230M kodlu ürünün alt T-Kızaklı gövdesindeki civata yeri standart değildir. Civata yeri bu ürüne özel işlenmektedir.

Product Nr. 1160-(M) Combined Sliding Clamp

- In the outer holes M20-M22-M24-M30 are used with the Reference Nr. imbus bolt (1160-620)-(1160-622)-(1160-624)-(1160-724)-(1160-730)
- Height clamping gap of the piece is 20-80mm.
- Back and forth movement distance is 75mm. Clamping force is 5500 kgf.

Product Nr. 1160-(LM) Combined Sliding Clamp

- In the outer holes M20-M22-M24-M30 are used with the Reference Nr. imbus bolt (1160-620)-(1160-622)-(1160-624)-(1160-724)-(1160-730)
- Height clamping gap of the piece is 20-80mm.
- Back and forth movement distance is 123mm. Clamping force is 5500 kgf.

Product Nr. 1165-(M) Combined Sliding Clamp

- In the outer holes M20-M22-M24-M30 are used with the Reference Nr. imbus bolt (1160-620)-(1160-622)-(1160-624)-(1160-724)-(1160-730)
- Height clamping gap of the piece is 30-80mm.
- Back and forth movement distance is 58mm. Clamping force is 10000 kgf.

Note: The drilling for cylinder head screw of the support element for 1160-230M - Nr.1165-230M is not standard. It is specially manufactured for this product.

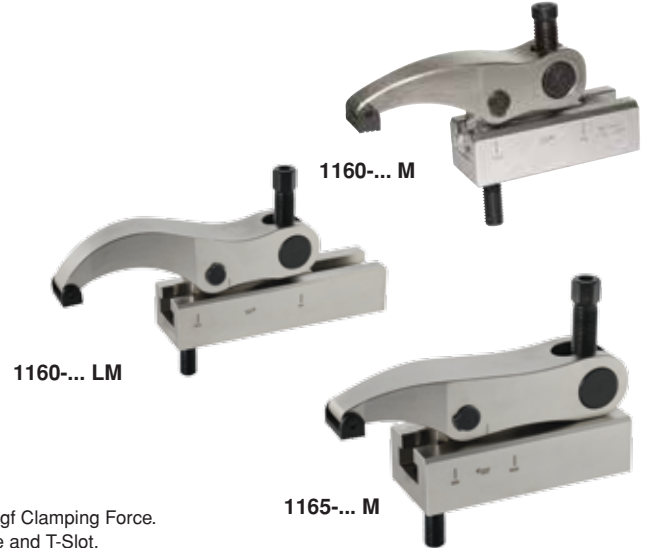
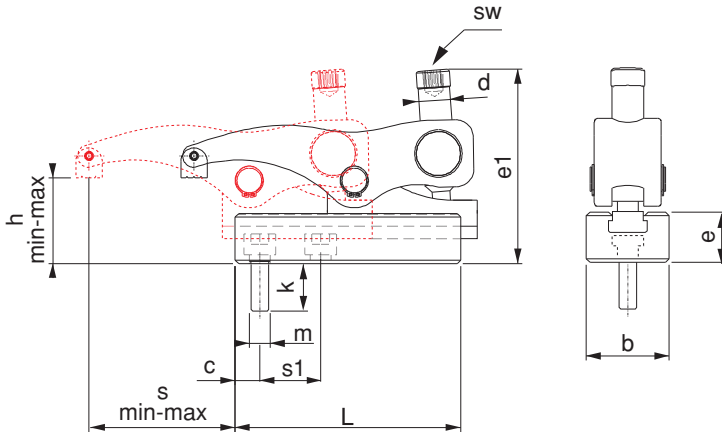

AVANTAJLARI;

- 1600 kgf - 2000 kgf sıkma kuvveti
- Delik ve T-Kanalda kullanım
- Kızak üzerinde kaydırarak değişik pozisyonlarda sabitleme
- imbus civatasıyla desteksiz yüksek ve düşük mesafeleri sıkar
- Pratik yapısından dolayı hızlı ve kolay şekilde bağlama sağlar

ADVANTAGES

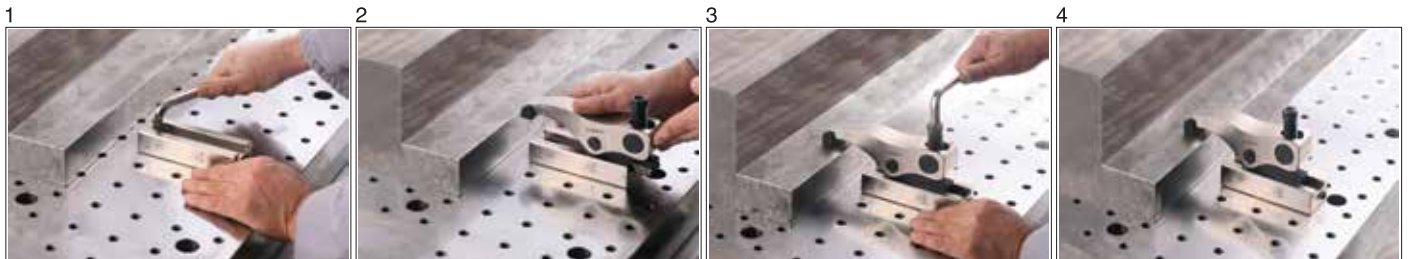
- 1600 kgf - 2000 kgf Clamping Force.
- Usings in the hole and T-Slot.
- Ability to be fixed in various positions by sliding on the slide.
- It clamps high and low distances without support with the imbus bolt.
- It provides rapid and easy connection due to its practical structure.



Referans Nr.	a	m	h		s	e1	e2	d	SW	L	b	e3	c	 (g)
			min	max										
1120-014 DT	14	M12	36	86	12-66	136	71.5	M14	8	104	38	38	13	2540
1120-016 DT	16	M12	36	86	12-66	136	71.5	M14	8	104	38	38	13	2540
1120-018 DT	18	M12	36	86	12-66	136	71.5	M14	8	104	38	38	13	2540
1120-014 LDT	14	M12	36	86	12-81	136	71.5	M14	8	130	38	38	13	2980
1120-016 LDT	16	M12	36	86	12-81	136	71.5	M14	8	130	38	38	13	2995
1120-018 LDT	18	M12	36	86	12-81	136	71.5	M14	8	130	38	38	13	3000

Ürün Nr. 1120-(DT) Alt Destekli

- M12 İmbus civata DIN 508 T-Pabuçla kullanılır.
- Parça yükseklik sıkma aralığı 36-86mm.
- İleri-geri hareket mesafesi 54mm'dir. Sıkma Kuvveti 1600 kgf.

Ürün Nr. 1120-(LDT) Alt Destekli

- M12 İmbus civata DIN 508 T-Pabuçla kullanılır.
- Parça yükseklik sıkma aralığı 36-86mm.
- İleri-geri hareket mesafesi 69mm'dir. Sıkma Kuvveti 1600 kgf.

Product Nr. 1120-(DT) Bottom Supported

- M12 imbus bolt is used with DIN 508 T-Nut.
- Height clamping gap of the piece is 36-86mm
- Back and forth movement distance is 54mm. Clamping force is 1600 kgf.

Product Nr. 1120-(LDT) Bottom Supported

- M12 imbus bolt is used with DIN 508 T-Nut.
- Height clamping gap of the piece is 36-86mm.
- Back and forth movement distance is 69mm. Clamping force is 1600 kgf.

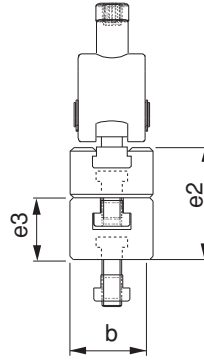
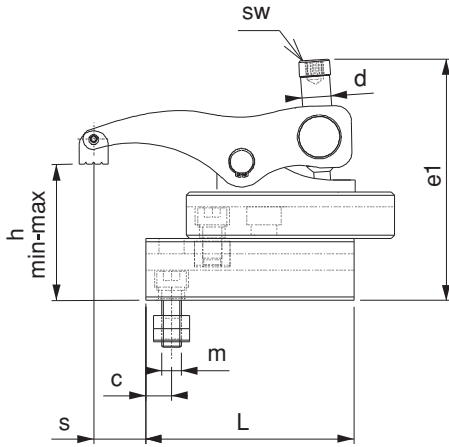

UYGULAMA;

- 1- Alt desteği iş parçasına uygun şekle getir sabitle
- 2- K.K.S.P destekler artırılarak istenilen mesafeye ulaşılır
- 3- K.K.S.P imbus civata ile T-Pabuca karşılık T-Kanala tak istenilen pozisyona getir.
- 4- Pabuç imbus civatasıyla iş parçasını sabitle

APPLICATION

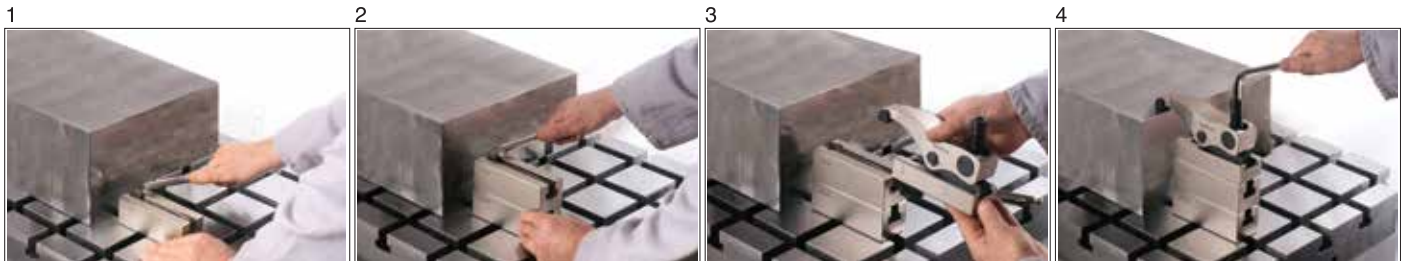
- 1- Bottom support is brought to suitable form with the work piece and then it is fixed.
- 2- Desired distance is reached by increasing K.K.S.P supports
- 3- K.K.S.P. is applied in T-Slot with imbus bolt against T-Nut
- 4- Work piece is fixed with the imbus bolt of the clamp



Referans Nr.	a	m	h		s	e1	e2	d	sw	L	b	e3	c	 (g)
			min	max										
1130-014 DT	14	M12	45	105	15-83	158	83	M18	10	130	48	45	17.5	4750
1130-016 DT	16	M12	45	105	15-83	158	83	M18	10	130	48	45	17.5	4775
1130-018 DT	18	M12	45	105	15-83	158	83	M18	10	130	48	45	17.5	4805
1130-020 DT	20	M12	45	105	15-83	158	83	M18	10	130	48	45	17.5	4885
1130-022 DT	22	M12	45	105	15-83	158	83	M18	10	130	48	45	17.5	4905
1130-014 LDT	14	M12	45	105	15-107	158	83	M18	10	170	48	45	17.5	5970
1130-016 LDT	16	M12	45	105	15-107	158	83	M18	10	170	48	45	17.5	5985
1130-018 LDT	18	M12	45	105	15-107	158	83	M18	10	170	48	45	17.5	6015
1130-020 LDT	20	M12	45	105	15-107	158	83	M18	10	170	48	45	17.5	6045
1130-022 LDT	22	M12	45	105	15-107	158	83	M18	10	170	48	45	17.5	6080

Ürün Nr. 1130-(DT) Alt Destek

- M12 İmbus civata DIN 508 T-Pabuçla kullanılır.
- Parça yükseklik sıkma aralığı 45-105mm
- İleri-geri hareket mesafesi 68mm'dir. Sıkma Kuvveti 2000 kgf.

Ürün Nr. 1130-(LDT) Alt Destek

- M12 İmbus civata DIN 508 T-Pabuçla kullanılır.
- Parça yükseklik sıkma aralığı 45-105mm
- İleri-geri hareket mesafesi 92mm'dir. Sıkma Kuvveti 2000 kgf.

Product Nr. 1130-(DT) Bottom Supported

- M12 imbus bolt is used with DIN 508 T-Nut.
- Height clamping gap of the piece is 45-105mm
- Back and forth movement distance is 68mm. Clamping force is 2000 kgf.

Product Nr. 1130-(LDT) Bottom Supported

- M12 imbus bolt is used with DIN 508 T-Nut.
- Height clamping gap of the piece is 45-105mm
- Back and forth movement distance is 92mm. Clamping force is 2000 kgf.

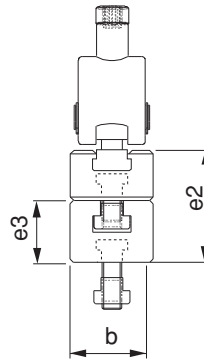
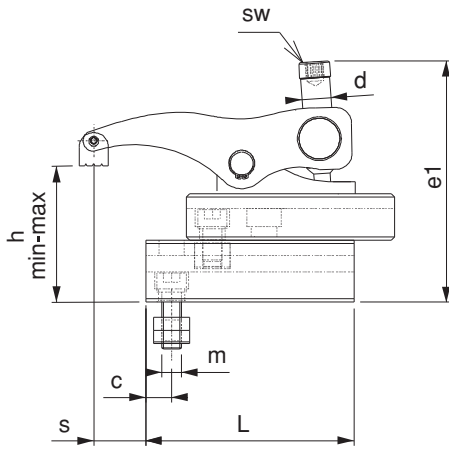
UYGULAMA;

- 1- Alt desteği iş parçasına uygun şekle getir sabitle
- 2- K.K.S.P destekler artırılarak istenilen mesafeye ulaşılır
- 3- K.K.S.P imbus civata ile T-Pabuca karşılık T-Kanala tak istenilen pozisyona getir.
- 4- Pabuç imbus civatasıyla iş parçasını sabitle

APPLICATION

- 1- Bottom support is brought to suitable form with the work piece and then it is fixed.
- 2- Desired distance is reached by increasing K.K.S.P supports
- 3- K.K.S.P is applied in T-Slot with imbus bolt against T-Nut
- 4- Work piece is fixed with the imbus bolt of the clamp

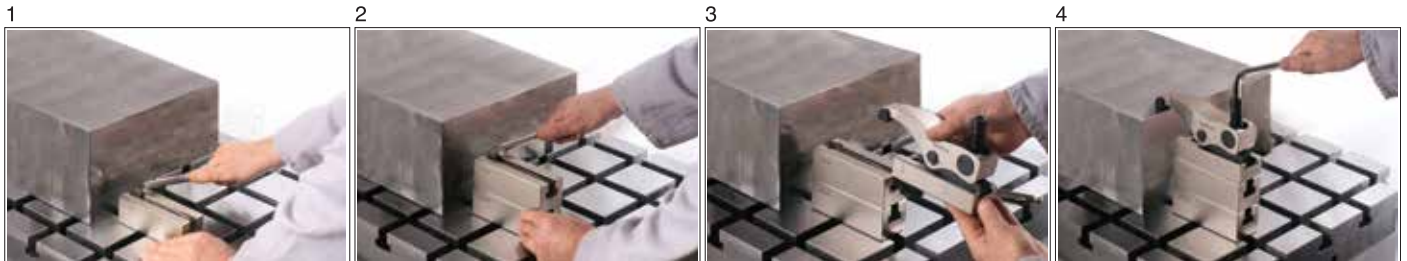

Referans Nr.	a	m	h		s	e1	e2	d	SW	L	b	e3	c	(g)
			min	max										
1150-118 DT	18	M16	48	113	18-96	173	90	M20	12	140	55	48	19.5	6625
1150-120 DT	20	M16	48	113	18-96	173	90	M20	12	140	55	48	19.5	6690
1150-122 DT	22	M16	48	113	18-96	173	90	M20	12	140	55	48	19.5	6750
1150-124 DT	24	M16	48	113	18-96	173	90	M20	12	140	55	48	19.5	6840
1150-128 DT	28	M16	48	113	18-96	173	90	M20	12	140	55	48	19.5	6960
1150-118 LDT	18	M16	48	113	18-128	173	90	M20	12	200	55	48	19.5	8770
1150-120 LDT	20	M16	48	113	18-128	173	90	M20	12	200	55	48	19.5	8830
1150-122 LDT	22	M16	48	113	18-128	173	90	M20	12	200	55	48	19.5	8885
1150-124 LDT	24	M16	48	113	18-128	173	90	M20	12	200	55	48	19.5	8985
1150-128 LDT	28	M16	48	113	18-128	173	90	M20	12	200	55	48	19.5	9000

Ürün Nr. 1150-(DT) Alt Destekli

- M16 İmbus civata DIN 508 T-Pabuçla kullanılır.
- Parça yükseklik sıkma aralığı 48-113mm
- İleri-geri hareket mesafesi 78mm'dir. Sıkma Kuvveti 2500 kgf.

Product Nr. 1150-(DT) Bottom Supported

- M16 imbus bolt is used with DIN 508 T-Nut.
- Height clamping gap of the piece is 48-113mm
- back-and- forth movement distance is 78mm. Clamping force is 2500 kgf.

Ürün Nr. 1150-(LDT) Alt Destekli

- M16 İmbus civata DIN 508 T-Pabuçla kullanılır.
- Parça yükseklik sıkma aralığı 48-113mm
- İleri-geri hareket mesafesi 110mm'dir. Sıkma Kuvveti 2500 kgf.

Product Nr. 1150-(LDT) Bottom Supported

- M16 imbus bolt is used with DIN 508 T-Nut.
- Height clamping gap of the piece is 48-113mm
- back-and- forth movement distance is 110mm. Clamping force is 2500 kgf.

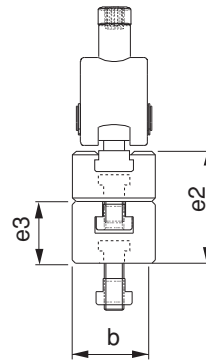
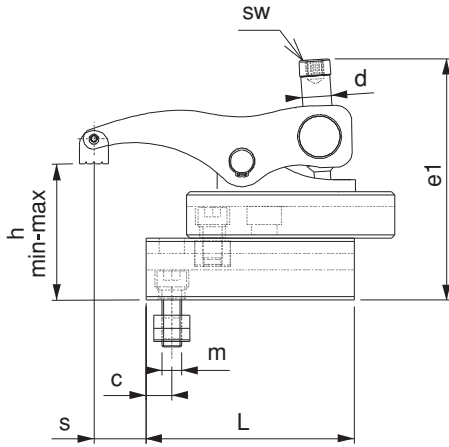
UYGULAMA;

- 1- Alt desteği iş parçasına uygun şekle getir sabitle
- 2- K.K.S.P destekler artırılarak istenilen mesafeye ulaşılır
- 3- K.K.S.P imbus civata ile T-Pabuca karşılık T-Kanala tak istenilen pozisyona getir.
- 4- Pabuç imbus civatasıyla iş parçasını sabitle

APPLICATION

- 1- Bottom support is brought to suitable form with the work piece and then it is fixed.
- 2- Desired distance is reached by increasing K.K.S.P supports
- 3- K.K.S.P is applied in T-Slot with imbus bolt against T-Nut
- 4- Work piece is fixed with the imbus bolt of the clamp

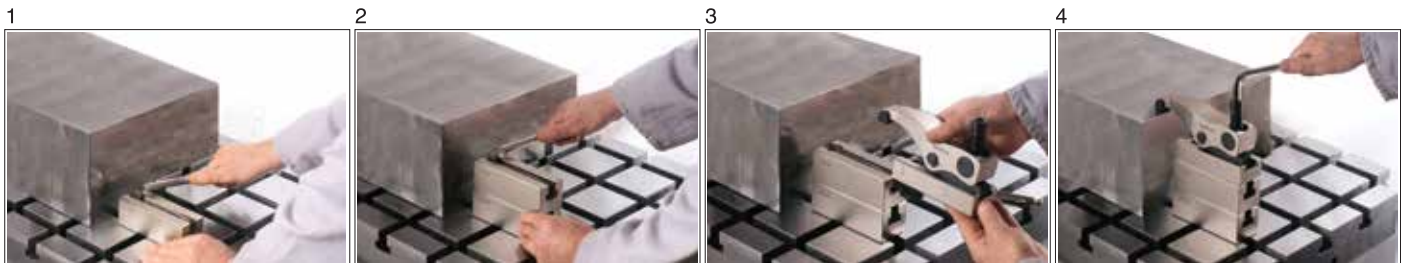

Referans Nr.	a	m	h		s	e1	e2	d	SW		L	b	e3	c	(g)
			min	max											
1160-222 DT	22	M20	79	139	17-92	235	114	M24	12	24	178	74	59	24	13330
1160-224 DT	24	M20	79	139	17-92	235	114	M24	12	24	178	74	59	24	13465
1160-228 DT	28	M24	79	139	17-92	235	114	M24	12	24	178	74	59	24	13580
1160-236 DT	36	M24	79	139	17-92	235	114	M24	12	24	178	74	59	24	13890
1160-222 LDT	22	M20	79	139	25-148	235	114	M24	12	24	256	74	59	24	17910
1160-224 LDT	24	M20	79	139	25-148	235	114	M24	12	24	256	74	59	24	18210
1160-228 LDT	28	M24	79	139	25-148	235	114	M24	12	24	256	74	59	24	18270
1160-236 LDT	36	M24	79	139	25-148	235	114	M24	12	24	256	74	59	24	18310

Ürün Nr. 1160-(DT) Alt Destekli

- M20-M24 İmbus civata DIN 508 T-Pabuçla kullanılır.
- Parça yükseklik sıkma aralığı: 79-139mm
- İleri-geri hareket mesafesi 75mm'dir. Sıkma Kuvveti 5500 kgf.

Product Nr. 1160-(DT) Bottom Supported

- M20-M24 imbus bolt is used with DIN 508 T-Nut.
- Height clamping gap of the piece is 79-139mm
- Back and forth movement distance is 75mm. Clamping force is 5500 kgf.

Ürün Nr. 1160-(LDT) Alt Destekli

- M20-M24 İmbus civata DIN 508 T-Pabuçla kullanılır.
- Parça yükseklik sıkma aralığı: 79-139mm
- İleri-geri hareket mesafesi 123mm'dir. Sıkma Kuvveti 5500 kgf.

Product Nr. 1160-(LDT) Bottom Supported

- M20-M24 imbus bolt is used with DIN 508 T-Nut.
- Height clamping gap of the piece is 79-139mm
- Back and forth movement distance is 123mm. Clamping force is 5500 kgf.

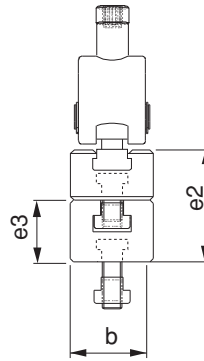
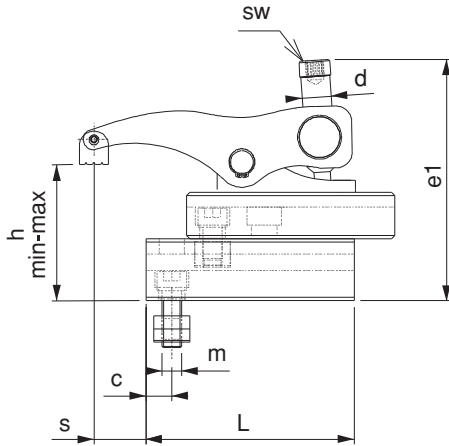



UYGULAMA;

- 1- Alt desteği iş parçasına uygun şekle getir sabitle
- 2- K.K.S.P destekler artırılarak istenilen mesafeye ulaşılır
- 3- K.K.S.P imbus civata ile T-Pabuca karşılık T-Kanala tak istenilen pozisyona getir.
- 4- Pabuç imbus civatasıyla iş parçasını sabitle

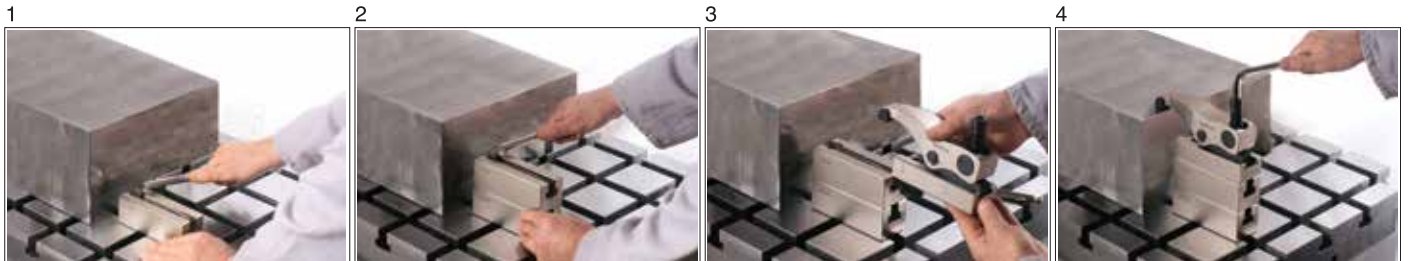
APPLICATION

- 1- Bottom support is brought to suitable form with the work piece and then it is fixed.
- 2- Desired distance is reached by increasing K.K.S.P supports
- 3- K.K.S.P is applied in T-Slot with imbus bolt against T-Nut
- 4- Work piece is fixed with the imbus bolt of the clamp



Referans Nr.		h		SW		
		min	max			
1120-0050	14-18	0	50	8	-	860
1120-0051	14-18	0	50	8	-	1050
1130-0060	14-22	0	60	10	-	1680
1130-0061	14-22	0	60	10	-	2150
1150-0062	18-28	0	65	12	-	2565
1150-0063	18-28	0	65	12	-	3360
1160-2080	22-36	20	80	12	24	5050
1160-2081	22-36	20	80	12	24	6900
1165-3080	22-36	20	80	-	24	6850

Üst Kızak Grubu

Upper Slide Group





Ürün Nr. 1120-1130-1150-1160-1165 Üst Kızak Grubu

- Üst Kızak Grubu: Dövme Çelik
- Sertleştirilmiş

Product Nr. 1120-1130-1150-1160-1165 Upper Slide Group

- Upper Slide Group: Forged Steel
- Hardened

Referans Nr.	g 		L	b	e	
1120-145	M10 M12	14-18	130	38	39	950
1130-047	M12 M16	18-28	130	48	39	1275
1130-147	M12 M16	18-28	170	48	39	1700
1150-053	M16 M18 M20	18-28	140	55	42	1700
1150-153	M16 M18 M20	18-28	200	55	42	2500
1160-074	M20 M22 M24	22-28	178	74	55	3650
1160-075	M30*	36	178	74	55	3650
1160-174	M20 M22 M24	22-28	256	74	55	5400
1160-175	M30*	36	256	74	55	5400
1165-085	M20 M22 M24	36	205	85	55	5300
1165-086	M30*	36	205	85	55	5300

T-Kızaklı Gövde

Body with Bottom T-Slide

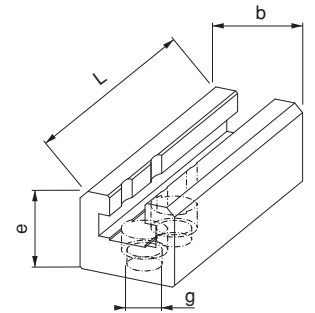

Ürün Nr. 1120-1130-1150-1160-1165 Alt T-Kızaklı Gövde

- Sertleştirilmiş

Product Nr. 1120-1130-1150-1160-1165 Body with Bottom T-Slide

- Hardened

Referans Nr.	g	a	L	b	e	(g)
1120-040	M10 M12	14	104	38	38	820
1120-140	M10 M12	14	130	38	38	1030
1130-045	M12 M16	14	130	48	45	1630
1130-145	M12 M16	14	170	48	45	2150
1150-048	M16 M18 M20	18	140	55	48	2070
1150-148	M16 M18 M20	18	200	55	48	3000
1160-059	M20 M22 M24	28	178	74	59	3980
1160-159	M20 M22 M24	28	256	74	59	5800

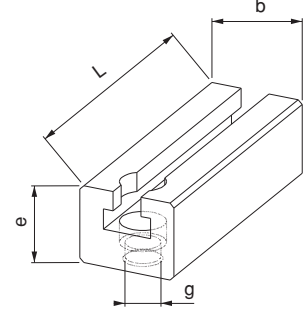
Ürün Nr. 1120-1130-1150-1160
Alt Destek

- Sertleştirilmiş

Product Nr. 1120-1130-1150-1160
Bottom Support

- Hardened

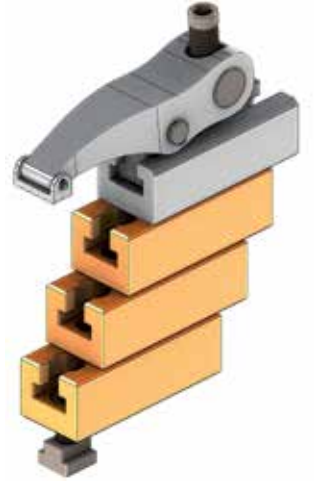
UYGULAMA;

- 1- Alt desteği iş parçasına uygun şekle getir sabitle
- 2- K.K.S.P destekler artırılarak istenilen mesafeye ulaşılır
- 3- K.K.S.P imbus civata ile T-Pabuca karşılık T-Kanala tak istenilen pozisyona getir.
- 4- Pabuç imbus civatasıyla iş parçasını sabitle

APPLICATION

- 1- Bottom support is brought to suitable form with the work piece and then it is fixed.
- 2- Desired distance is reached by increasing K.K.S.P supports
- 3- K.K.S.P is applied in T-Slot with imbus bolt against T-Nut
- 4- Work piece is fixed with the imbus bolt of the clamp

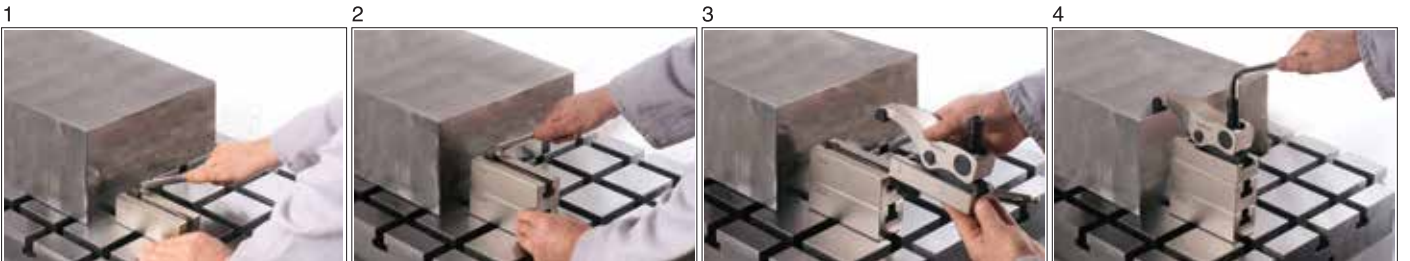

Referans Nr.	m	L	SW		(g)
1120-0714	M14	72	8	-	138
1130-0818	M18	83	10	-	235
1150-0920	M20	96	12	-	360
1160-1024	M24	134	12	24	795
1165-1124	M24	149	-	24	950

Ürün Nr. 1120-1130-1150-1160-1165 Pabuç Kaldırma Civata ve Somunu

- Sertleştirilmiş
- Siyah Kaplama

Product Nr. 1120-1130-1150-1160-1165 Clamp Lifting Bolt and Nut

- Hardened
- Black Coating

Pabuç Kaldırma Civata ve Somunu

Clamp Lifting Bolt and Nut

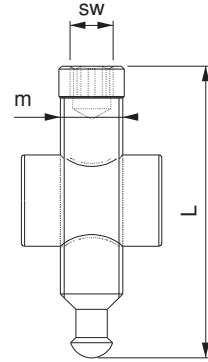

Referans Nr.	m	L	d	sw	(g)
1120-310	M10	29	16.5	8	28
1120-312	M12	29	16.5	8	34
1130-412	M12	30	20.5	10	45
1130-416	M16	34	20.5	10	75
1150-516	M16	34	24.5	12	75
1150-518	M18	38	24.5	12	90
1150-520	M20	38	24.5	12	105
1160-620	M20	45	34	12	170
1160-622	M22	49	34	12	217
1160-624	M24	45	34	12	390
1160-724	M24	55	34	12	405
1160-730	M30*	66	38.5	12	450
1165-820	M20	45	34	12	170
1165-822	M22	49	34	12	217
1165-824	M24	45	34	12	390
1165-924	M24	55	34	12	405
1165-930	M30*	66	38.5	12	400

Ürün Nr. 1120-1130-1150-1160-1165 Sabitleme İmbus Civatası

- M12-M16-M18-M20 dış delikler için
- Kalite 10.9
- Siyah kaplama



Product Nr. 1120-1130-1150-1160-1165 Imbus Bolt for Fixing

- For M12-M16-M18-M20 thread holes
- Quality 10.9
- Black Coating

Sabitleme İmbus Civatası

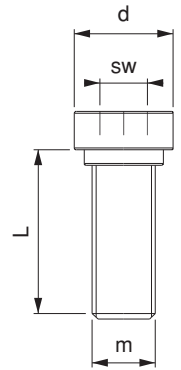
Imbus Bolt for Fixing



Referans Nr.		m	L	d	sw	
1120-512	12	M10	29	16.5	8	48
1120-514*	14	M12	29	16.5	8	54
1130-614*	14	M12	30	20.5	10	80
1130-616	16	M12	30	20.5	10	100
1130-618	18	M12	30	20.5	10	130
1130-620	20	M12	36	20.5	10	180
1130-622	22	M12	36	20.5	10	220
1150-718*	18	M16	34	24.5	12	145
1150-720	20	M16	34	24.5	12	190
1150-722	22	M16	42	24.5	12	260
1150-724	24	M16	42	24.5	12	350
1150-728	28	M16	42	24.5	12	470
1160-822	22	M20	45	34	12	320
1160-824	24	M20	45	34	12	410
1160-826*	28	M24	45	34	12	550
1160-828	28	M24	55	34	12	580
1160-832	32	M24	61	34	12	603
1160-836	36	M24	66	38.5	12	865
1165-922	22	M20	45	34	12	320
1165-924	24	M20	45	34	12	410
1165-926*	28	M24	45	34	12	550
1165-928	28	M24	55	34	12	580
1165-932	32	M24	61	34	12	603
1165-936	36	M24	66	38.5	12	865

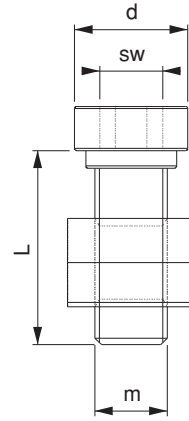

Ürün Nr. 1120-1130-1150-1160-1165 Sabitleme İmbus Civata ve T-Pabuç

- (a) 14-28 T-Kanal sabitleme imbus civata ve T-Pabuç DIN 508
- Kalite 10.9
- Siyah Kaplama
- Yıldızlı olan kodlar alt destek civatalarıdır.

Prod. Nr. 1120-1130-1150-1160-1165 Fixing Imbus Bolt and T-Nut

- (a) 14-28 T-Slot fixing imbus bolt and T-Nut DIN 508
- Quality 10.9
- Black Coating
- Star-marked codes are bottom support bolts.

Referans Nr.	a	b	c	
1120-DP	13.5	26.5	12	15
1120-BSP	15.5	26.5	12	18
1120-ESP	18	26.5	12	21
1130-DP	17	32	15	20
1130-BSP	19	32	15	30
1130-ESP	22	32	15	30
1150-DP	19	38	18	40
1150-BSP	21	38	18	40
1150-ESP	25	38	18	50
1160-DP	22	44	22	55
1160-BSP	25	44	22	70
1160-ESP	28	44	22	80
1165-DP	22	44	22	55
1165-BSP	25	44	22	70
1165-ESP	28	44	22	80

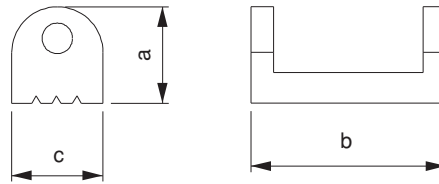

Ön Baskı Pabucu

Front Press Clamp



Ürün Nr. 1120-1130-1150-1160-1165 Ön Baskı Pabucu

- Ürün DP : Düz parça sıkma
- Ürün BSP: Boyuna silindirik sıkma
- Ürün ESP: Enine silindirik sıkma
- Siyah Kaplama

Prod. Nr. 1120-1130-1150-1160-1165 Front Press Clamp

- Product DP : Straight piece clamping
- Product BSP: Longitudinal cylinder clamping
- Product ESP: Lateral cylinder clamping
- Black Coating