



CereScan

Metrology-Grade Handheld Laser Scanning System

SMART HANDHELD BLUE LASER 3D SCANNER

MINI-SIZE PORTABLE BLUE LASER 3D SCANNER

Perfect Metrology Solution



ZG TECHNOLOGY CO., LTD.

ZG TECHNOLOGY CO., LTD.

ABOUT ZG

ZG Technology is a professional 3D scanner solution provider, which is an expert in research and developing 3D technology. ZG portfolio includes metrology-grade portable 3D laser scanner, optical tracking 3D scanner, smart in-line inspection system, smart full-color 3D scanner and photogrammetry system, which can widely meet different customer requirements, such as quality inspection, reverse engineering, VR&AR etc.

TECHNICAL TEAM

ZG Technology R&D team has 7 doctors and 15 masters, all are the experts in photogrammetry and 3D measurements. ZG Technology is based on independent Intellectual Property Right, cutting edge technologies and achievements from Wuhan University, which gets more than 130 national patents and software copyrights, and has received more than 20 national and ministerial-level qualification awards.

A Professional 3D Scanner
Solution Provider in the World

AWARDS & CERTIFICATES



CereScan

Smart Handheld Blue Laser 3D Scanner

CereScan, ZG's newly launched mini-size portable metrology-grade 3D scanner, is designed to optimize the scanning performance for hard-to-reach areas like pocket and narrow groove etc. With the features of mini size and lightweight design, users can easily operate the device with one hand, which brings great simpleness to the scanning process.

Based on the powerful and sophisticated algorithm, CereScan can provide users with rapid and efficient 3D scanning experience. Equipped with built-in photogrammetry system inside, it also can be used to scan big workpieces with better volumetric accuracy control.



650g

Net Weight
650g



Dimension
215×95×45mm



Mobilephone



CereScan



AtlaScan



- Lightweight alloy protective shell
- Brand-new mini structure design
- Easy-to-use



- Integrated anti-slip scanner cover
- Great ergonomic design for comfortable operation



PRODUCT FEATURES



Great Adaptability

- Shorter camera distance in mini size to capture hard-to-reach places like deep groove, pocket and hole etc easily
- Scanning area up to 600×550mm. good to scan big workpiece

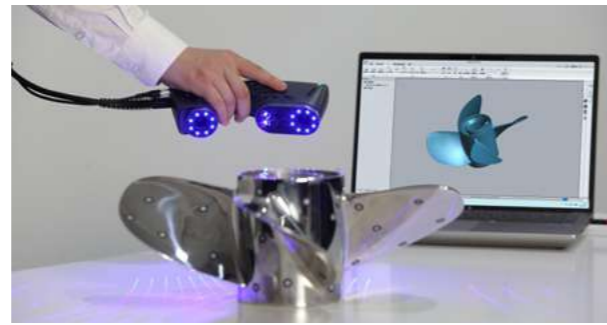

Significant Efficiency

- Scanning speed up to 2,480,000 measurements/s
- Scan tremendous mesh data in real time



Blue Laser Technology

- 34 blue laser lines for big scanning area
- Scan dark & shiny part directly without spraying



High Accuracy

- Accuracy up to 0.01mm under ultra-fine scanning mode
- Volumetric accuracy up to 0.015mm+0.02mm/m with built-in photogrammetry system

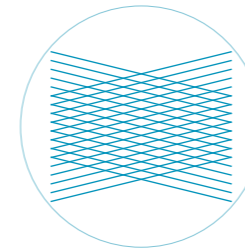
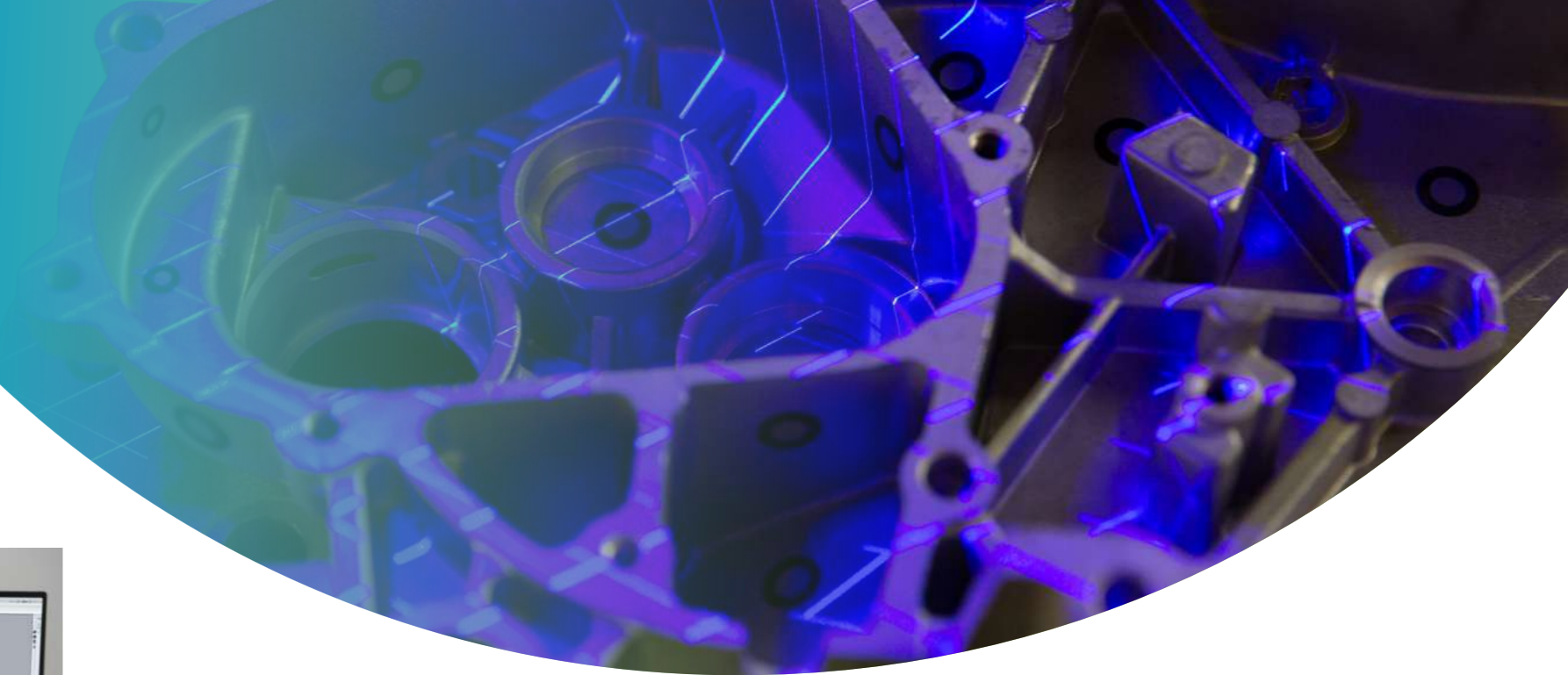

Standard Scanning Mode

26 blue laser lines to improve scanning efficiency dramatically



Ultra-fine Details Scanning

7 parallel blue laser lines to feature more details

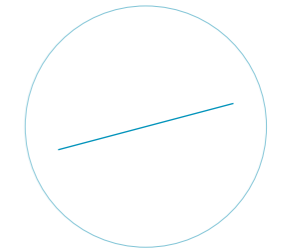

Single laser line scanning

To scan hard-to-reach places well



Built-In Photogrammetry System

To secure better volumetric accuracy for big workpiece easily only by adopting scale bar, no need to place coded marker anymore



Intelligent Interactive System

To realize the remote control scanning process by simple button operations



Wireless Scan Mode

By adopting wireless module into CereScan, it will be free to move and easy to scan

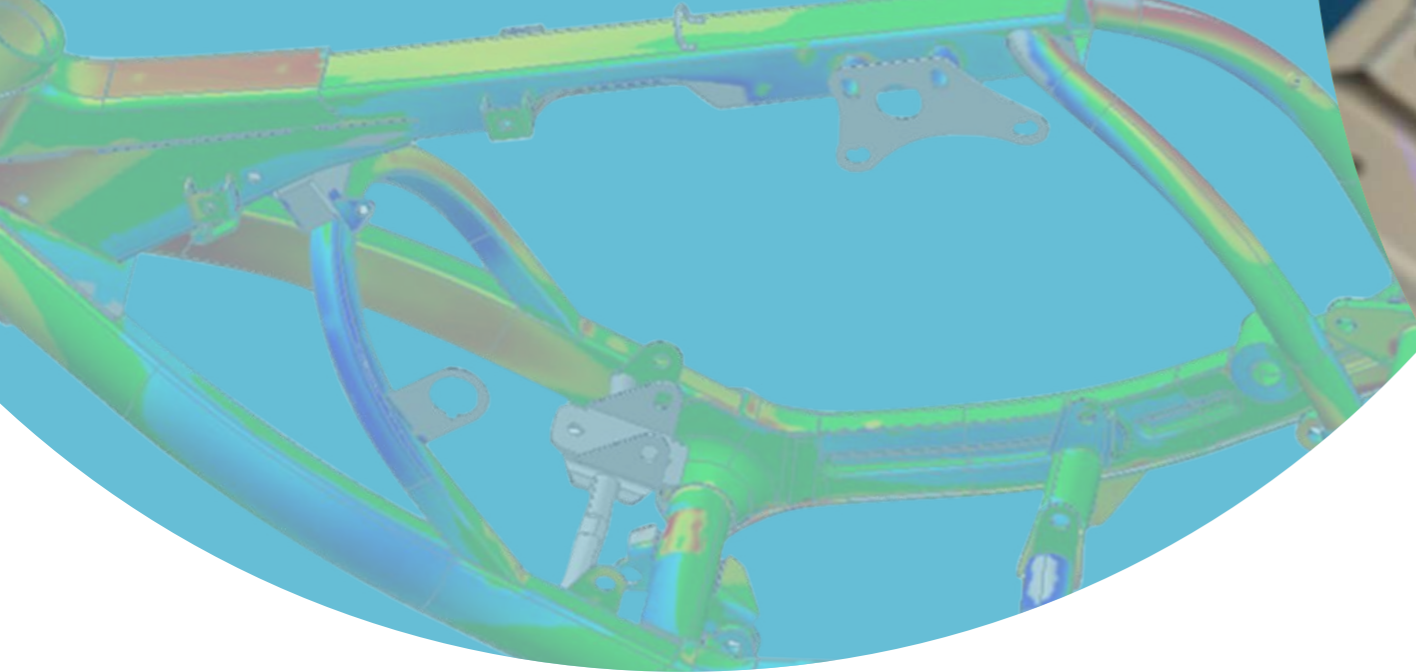

“ Make Measurement & Inspection Easy, Intuitive and Efficient

SOFTWARE FEATURES

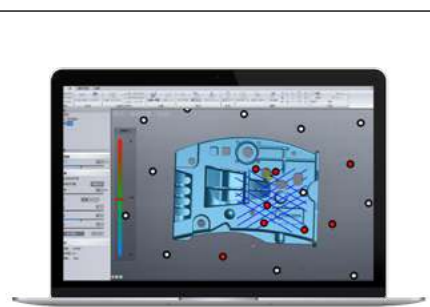

▶ Real-time Mesh & Local Resolution

- Scan mesh data in real-time
- Optimize mesh quality to get more details
- Reduce data file size to save post-processing time



▶ Built-in Inspection Module

- Support GD&T inspection
- Generate 3D comparison color map & measurement report

APPLICATION DIRECTION

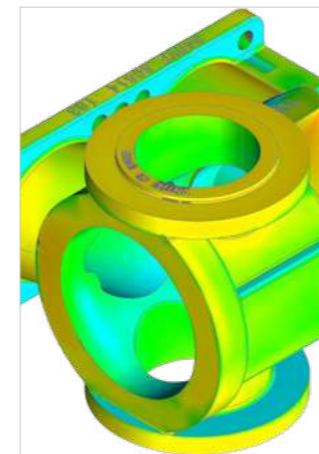

Quality Control

- CAD alignment
- Dimensional inspection
- Virtual assembly

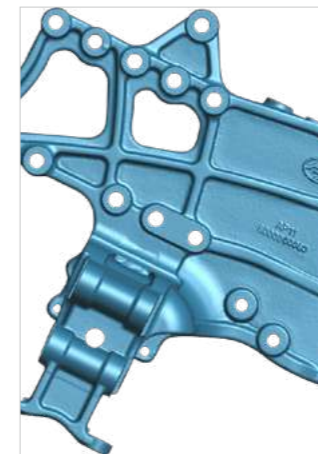

Inspection & Maintenance

- GD&T
- Wear inspection
- Trend analysis

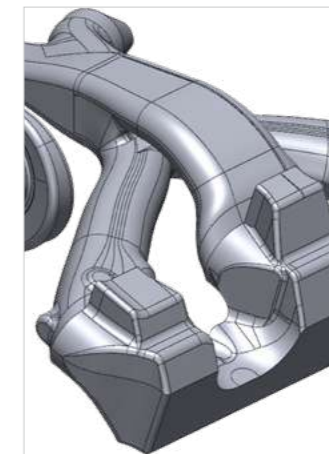

Reverse Engineering

- Reverse mappings
- Rapid prototyping and manufacturing
- Industrial fixture design



Culture

- Cultural relic & sculpture digitalization
- Art and design



APPLICATION CASE



AUTOMOTIVE

- Reverse engineering
- Competitive product analysis
- Automotive repacking
- Interior customization
- Modeling and design



AEROSPACE

- Rapid prototyping
- Quality control & inspection
- (MRO) wear and tear analysis
- Aerodynamics
- Stress analysis



HEAVY INDUSTRY

- Quality control
- Reverse engineering
- MRO and wear analysis
- Mechanical & tooling design and modification
- OEM and parts recycling



MOLD & CASTING

- Quality inspection & control
- Virtual assembly
- Wear and tear analysis
- Reverse engineering
- Industrial fixture design & modification



CULTURE & EDUCATION

- Cultural relic
- Art
- Sculpture
- Education & Research



MEDICAL

- Orthosis & prosthesis design and manufacture
- Plagiocephaly treatment
- Wound monitoring
- Biological specimen



TECHNICAL SPECIFICATIONS

Model	CereScan
Measurement Rate-Standard Mode	2,480,000 measurements/s
Measurement Rate-Fine Mode	1,250,000 measurements/s
Scanning Area	Up to 600×550mm
Laser Source Class II (Eye Safe)	26 blue laser lines+extra single blue laser line+extra 7 blue laser lines
Resolution	Up to 0.02mm
Accuracy-Standard Mode	Up to 0.02mm
Accuracy-Fine Mode	Up to 0.01mm
Volumetric Accuracy-Standard Mode	0.015+0.035mm/m
Volumetric Accuracy+Photoshot Max	0.015+0.015mm/m
Volumetric Accuracy+Scale Bar	0.015+0.02mm/m
Stand-off Distance-Standard Mode	300mm
Stand-off Distance-Fine Mode	150mm
Depth of Field-Standard Mode	450mm
Depth of Field-Fine Mode	150mm
Depth of Field-Furthest Mode	550mm
Weight	0.65kg
Dimension	215×95×45mm
Connection Standard	USB 3.0
Working Temperature	-10~40°C
Working Humidity (Non-condensing)	10%~90%
Export Format	.asc, .stl, .obj, .ply, .txt, .xyz and etc. Customized services available
Compatible Softwares	3D Systems(Geomagic Solutions), InnovMetric Software(PolyWorks), Dassault Systems(CATIAV5 and SolidWorks), PTC(Pro/ENGINEER), Autodesk(Inventor, Alias, 3ds Max, Maya, Softimage), Siemens(NX and Solid Edge) etc.
Patents	CN106228603B, CN208174805U, CN111486801B, CN212539085U, CN106767895B, CN106204544B, CN304321958S, CN108038878B, CN211046994U, CN306620676U, CN214224013U, CN214924384U, CN215572695U

ZG Technology Co., Ltd.

Website: www.3d-zg.com

Tell: +86 27 87741893

Email: overseas@3d-zg.com

Add: Building No.1, Dingxin Industrial Park, No.18,
Jiayuan Road, Hongshan District, Wuhan, China.

