

GARNET Mini

3 Axis NC Compact Processing Center with Copy Router Function



Features

Compact milling center with copy router function, on the 3 surfaces of the aluminum and plastic profiles, with parametric program templates, developed to perform operations such as lock, handle, hinge, latch slot and opening processes.

- 10" Touchscreen
- Easy to program user interface
- Easy profile positioning with gauge and laser marking
- Spindle motors running independently on 3 different surfaces

Standard Equipment

- Cooling system
- Horizontal and vertical pneumatic clamps (2 pcs top, 2 pcs front)
- 3 piece 6mm milling cutters
- Right and left profile gauge
- Laser marking

Optional Equipment

- 5, 6, 8 and 10 mm milling cutters

Motor 1				Motor 2				Spindle				Air Pressure	Air Consumption	Gross Net	
HP	n	Hz	I (230 V)	HP	n	Hz	I (230 V)	∅ D max.	H	X	Y	Z			
4	18000	300	7 A	1	3000	50	4,6 A	13 mm	118 mm	350 mm	150 mm	120 mm	6 - 8 bar	40 L / dk.	1000 kg 800 kg
3	r.p.m			0,75	r.p.m										

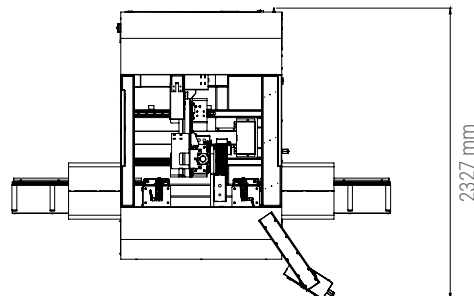
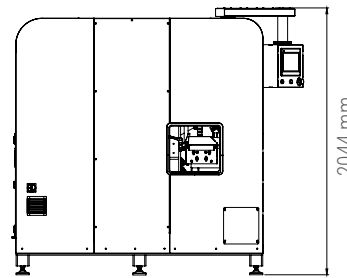
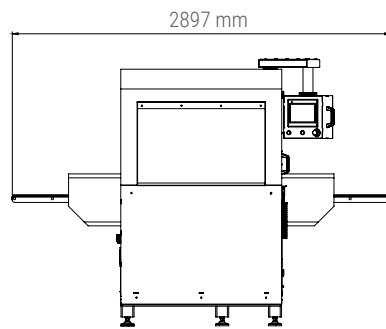

GARNET Mini

3 Axis NC Compact Processing Center with Copy Router Function

MACHINING LENGTHS

X Axis (Longitudinal)	350 mm
Y Axis (Lateral)	150 mm
Z Axis (Vertical)	120 mm

POSITIONING SPEED

X Axis (Longitudinal)	30 m/min
Y Axis (Lateral)	30 m/min
Z Axis (Vertical)	30 m/min

AIR

Pressure	6-8 Bar
Consumption	40 L / min

ELECTRICAL

Maximum power	12 kW
Voltage	400V 3P, PE AC
Frequency	50-60 Hz

SPINDLE

Spindle with cooling fan	3
Maximum power	3 kW
Maximum rotation speed	18.000 rpm
Tool holder	ER 20

PROFILE POSITIONING

Right and left profile gauge	●
Laser marking	●

PROFILE TIE-DOWN MEASUREMENTS

Xmax / Xmin (Longitudinal)	- / 660 mm
Ymax / Ymin (Lateral)	150 mm / -
Zmax/ Zmin (Vertical)	120 mm / -

CONTROL UNIT

Touchscreen	10"
Data transfer via USB	●
Smart CAM post processing	○

OPERATIONAL AREA

Clamps, standard quantity	4
Automatic lubrication in processing area	●
Guard cabin for machining area	●

● Standard ○ Optional