

LEPUS - X

CNC ACP Processing Machine (3 Axis)

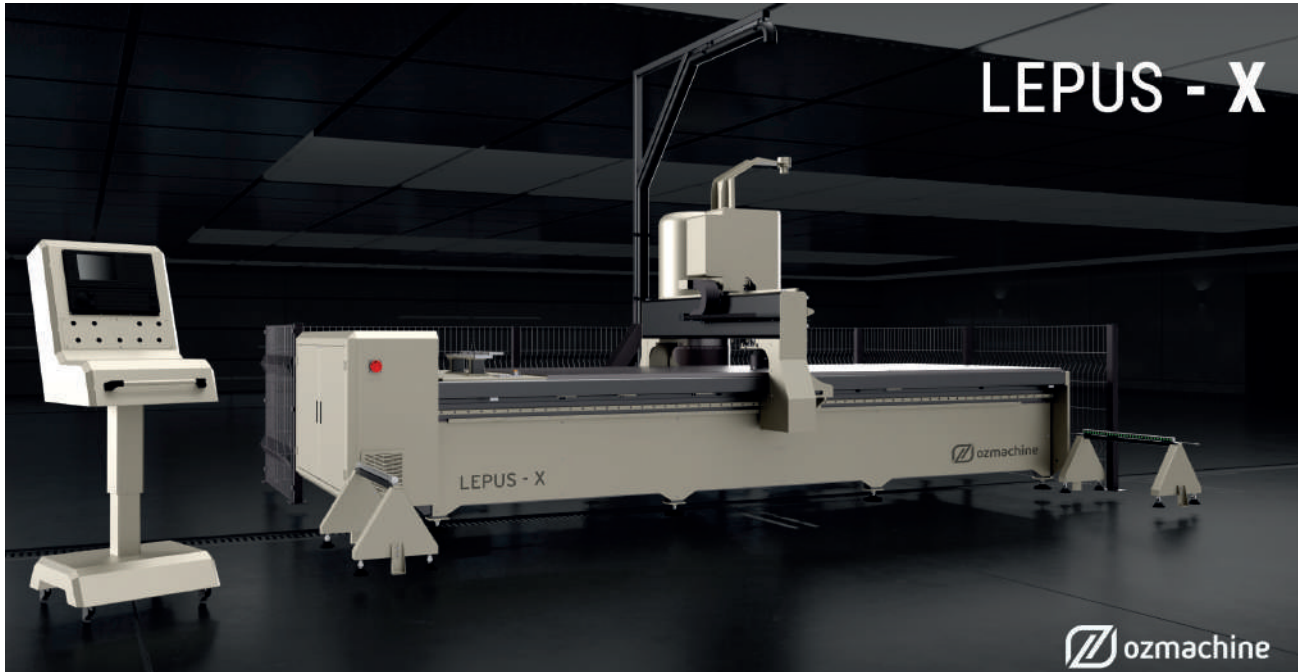

ozmachine



The 3-Axis CNC controlled panel and profile processing machine LEPUS – X is developed to cut v-channel opening and similar operations on various composite panels and plates. Thanks to its automatic tool magazine system with capacity for 5 tools, LEPUS – X saves time when switching to different operations. In addition, LEPUS - X enables processing of aluminum, wooden, plastic and various materials by replacement of the milling cutter.

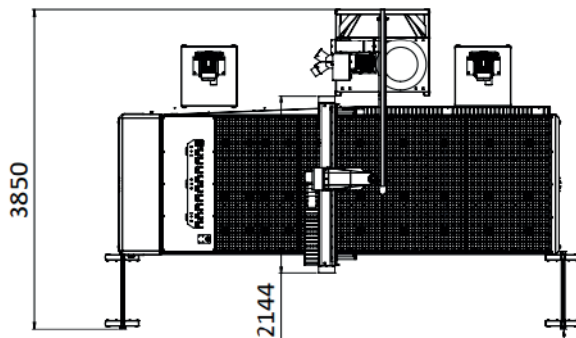
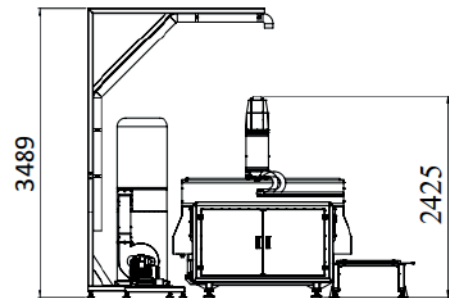
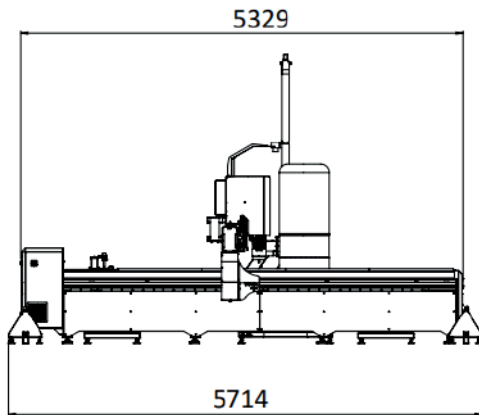

LEPUS - X

CNC ACP Processing Machine (3 Axis)

MACHINING LENGTHS

X Axis (Longitudinal)	4000 mm
Y Axis (Lateral)	1600 mm
Z Axis (Vertical) – without tool	250 mm
Insertable Panel Dimensions Min./Max.	500x300 mm /4000x1600 mm

POSITIONING SPEED

X Axis (Longitudinal)	55 m/Min
Y Axis (Lateral)	55 m/Min
Z Axis (Vertical)	15 m/Min

SPINDLE MOTOR

Motor Power	7.5 kW
Motor rotation speed	24000 rpm
Tool Holder	ISO 30
Cooling Type	Elektro Fan

TOOL DIAMETER

Carbide Milling Cutter	5 mm
Grout Milling Cutter	10 mm

DUST EXTRACTION MOTOR (VELA)

Motor Power	3 kW
Motor Rotation Speed	3000 rpm
Air Flow	700 m ³ /h

VACUUM MOTOR X 2

Motor Power	7,5 kW
Motor Rotation Speed	3000 rpm

CONTROL UNITS

CNC control unit	•
Data transfer from PC via CF card, USB flash drive or remote network connection	•
Industrial PC - Touch Screen	15" HMI

AIR - ELECTRIC

Voltage	400 V
Maximum Power	38 kW
Frequency	50-60 Hz
Pressure	6-8 Bar

OPERATIONAL AREA

Dust Extraction System	•
External Button Controlled Vacuum Zones/ Vacuum in independent areas	•
Automatic Tool Length Measurement	•
X and Y Axis Reference Stop	•
Handwheel Control For Manual Movement And Adjustments	•
Laser Safety Barrier	•
Metal Barriers On Three Sides Blocking Access To The Work Area	•
Spare ISO 30 Tool Holder	○
Spare Tool Holder Pens	○
Lubricated Vacuum Pump	○
2D and 3D Geometry Processing Capability With Alphacam CAD/CAM Software	○

• Standard ○ Optional

Özçelik Makina ürünlerini sürekli geliştirmektedir. Buna bağlı olarak bu dokümanda yer alan bilgileri, haber vermeksizin değiştirme hakkına sahiptir. Tüm ölçüler ve ağırlıklar referans değerlerdir. Ocak 2023 itibarıyla geçerlidir.