

emintosun®

THE ULTIMATE WOODEN DOOR PRODUCTION MACHINES

be
original

WOODMASTER PANGEA

Cnc kapı kol - kilit ve menteşe yeri açma makinesi
Cnc Door frame , door lock and hinges milling machine

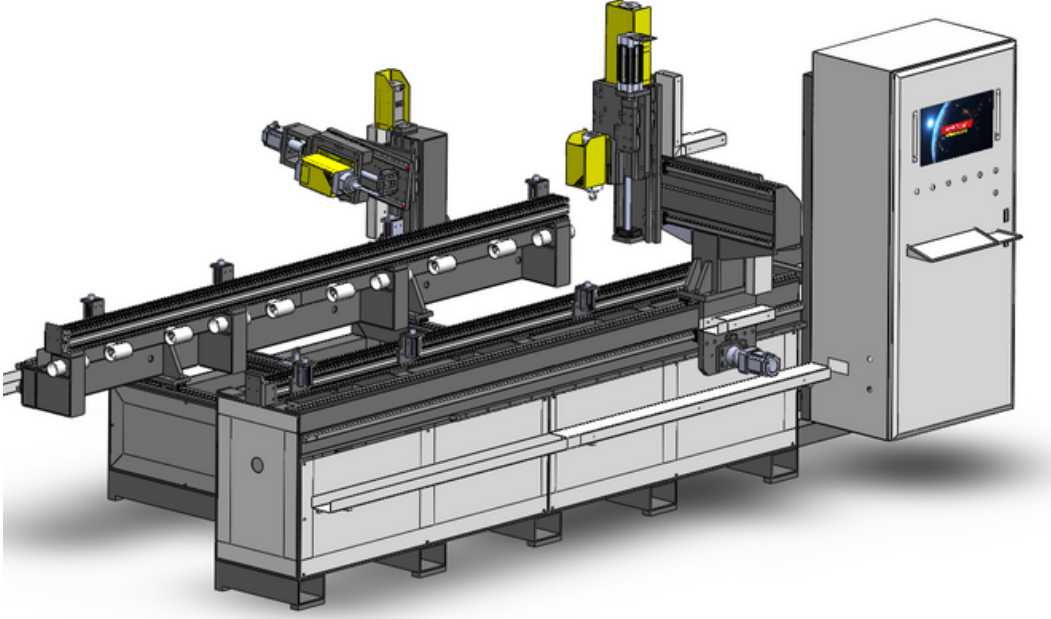

TEKNİK ÖZELLİKLER /TECHNICAL SPECS



KOL/KİLİT AÇMA MOTOR GÜCÜ
HANDLE/LOCK MILLING MOTOR POWER
1 X (2.2) KW 12000 RPM



MENTEŞE MOTOR GÜCÜ
SPINDLE MOTOR POWER
1 X (1.5) KW 12000 RPM



SERVO MOTOR GÜCÜ
SERVO MOTOR POWER
6 X (0.75) KW 3000 RPM



CNC ÇALIŞMA HIZI
CNC FEEDRATE
30 M/MIN



KOL-KİLİT EKSEN ÇALIŞMA ALANI(X,Y,Z)
LOCK/HANDLE WORKING AREA X,Y,Z
2350-150-60MM



MENTEŞE EKSEN ÇALIŞMA ALANI(X,Y,Z)
HINGE WORKING AREA X,Y,Z
2350-120-60MM



MİN-MAX KAPI(E-B-Y)
MIN-MAX DOOR(W-L-H)
(400-1220 MM)(B,L-∞)(0-60MM)



MANUEL KAPI YÜKLEME
MANUEL DOOR LIFTING



CAD/CAM TASARIM
CAD/CAM DESIGN



VOLTAJ
VOLTAGE
380 V 50/6 HZ



HAVA BASINCI
AIR PRESSURE
6-8 BAR



BOYUTLARI (E-B-Y)
DIMENSIONS (W-L-H)
2300 - 4000- 2200 MM



AĞIRLIK
WEIGHT
1300 KG



TOZ EMME
ÇIKIŞ ÇAP
DUST
E.HOLES
4 X Ø60MM

