

# Compact & Compact max™

## Roll-bag Converting

For in-line or out-of-line production of garbage bags on roll.

- Medium and heavy gauge film
- Cost-efficient bag machine



# Compact

## Roll-bag Converting

The Compact can be configured for production of bottom sealed bags, with or without gussets, and star-sealed bags. It is mainly targeted at medium capacities and is the perfect choice for in-line applications where the extruder is the bottleneck, and for shorter length garbage bags.

The Compact max™ is an excellent choice for medium and heavy gauge films where extra high outputs are required. The Compact max™ has a sealing section

with more than twice the sealing time than that of the Compact, which means even better performance with heavier gauge films.

The Compact is a low investment solution and the right choice for your production of bags on roll, when space and personnel are limited. Possibility to install secure remote access via internet. Automated downstream roll handling/packaging can also be integrated.

### Technical data for Compact

	Compact	Compact max™
Max. sealing width	860 mm (33.9 in)	860 mm (33.9 in)
Min. bag length	360 mm (14.2 in)	600 mm (23.6 in)
Max. bag length**	1500 mm (59 in)	1500 mm (59 in)
Max. speed*	120 m/min (395 ft/min)	120 m/min (395 ft/min)
Max. cycles/min	330 bags	200 bags

\*) Depending on film quality and thickness.

\*\*) Can be increased.

Additional equipment: print registration, all kinds of folding equipment (before and after sealing), cores, hot-melt, twist-tie, PP-string, paper tape.

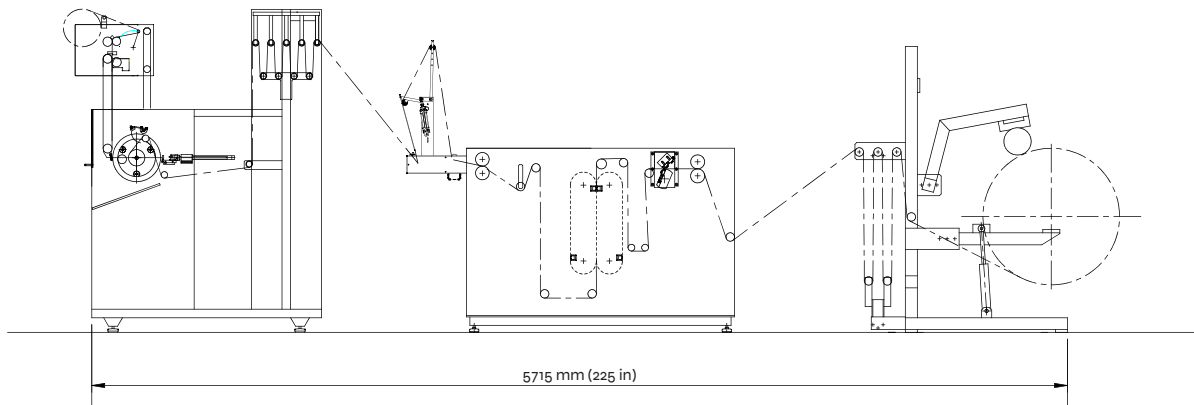

Compact max™ out-of-line

### Types of bags

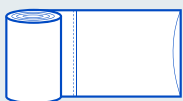

Bottom sealed

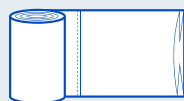

Gusseted

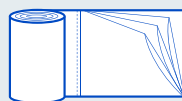

Star-sealed

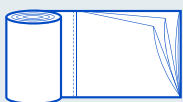

Garbage sacks folded

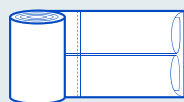

Garbage sacks folded

Watch video of Compact

