

HRW Winder

Winding of film and nonwoven

Automatic winding of thin and medium gauge film.

→ Industrial film, nonwoven or similar webs

→ In-line or out-of-line



Damp proof membrane

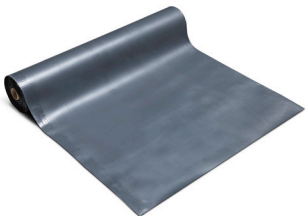

Insulation foil



Vapor barrier



HRW Winder

Winding of film and nonwoven

The HRW is a high-speed roll winder for winding of flat single-layer, tubular or folded industrial film or similar web applications.

The HRW can operate for both in-line and out-of-line production and is designed to meet customers' request for narrow footprint.

Cutting is done with a tear-off knife or with a perforation unit especially designed for thin and medium film applications. The HRW can make up to 16 roll changes per minute. This makes the HRW the optimal solution for high-speed winding of small diameter rolls.

Technical data for HRW

Film thickness	From 5 µm up to 4 x 100 µm
Max. roll diameter	220 mm (8.7 in)
Max. roll changes	16/min
Min./max. winding width	600/1200 mm (23.6/47.2 in)
Max. film speed*	220 m/min (720 ft/min)
Paper core	From Ø 38 mm (1.5 in)

*) Depending on film quality and thickness.

Additional equipment: Unwinder, perforator, slitting knife, folding equipment, paper tape and automated packaging equipment.

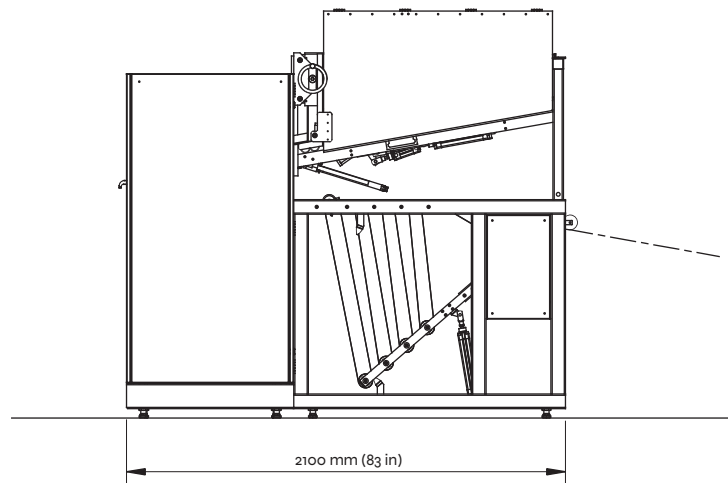

HRW Winder

At Roll-o-Matic we always focus on your production demands - therefore all Roll-o-Matic developments are customer-driven and customer-oriented.

The HRW-series has been developed according to our customers' requirements for high-speed, user-friendly and easy to operate winding, where the key parameters are: modest investment, stability, outstanding performance and Return on Investment.

Watch video of
HRW Winder

