

Paper Sticking Machine

Model: JZIII

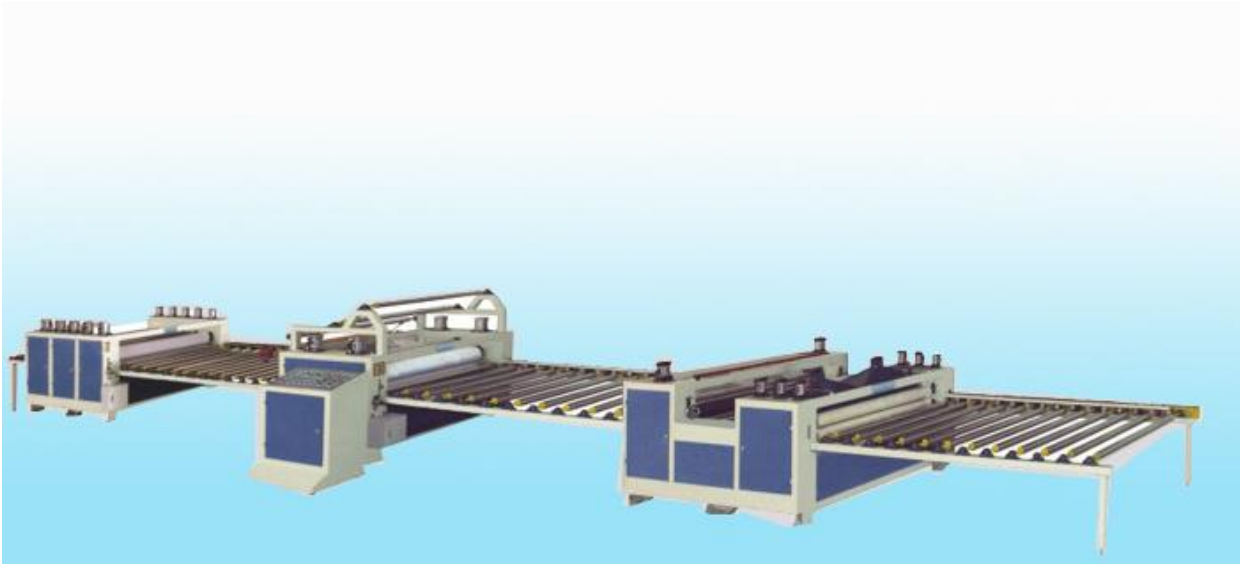

FUNCTIONS

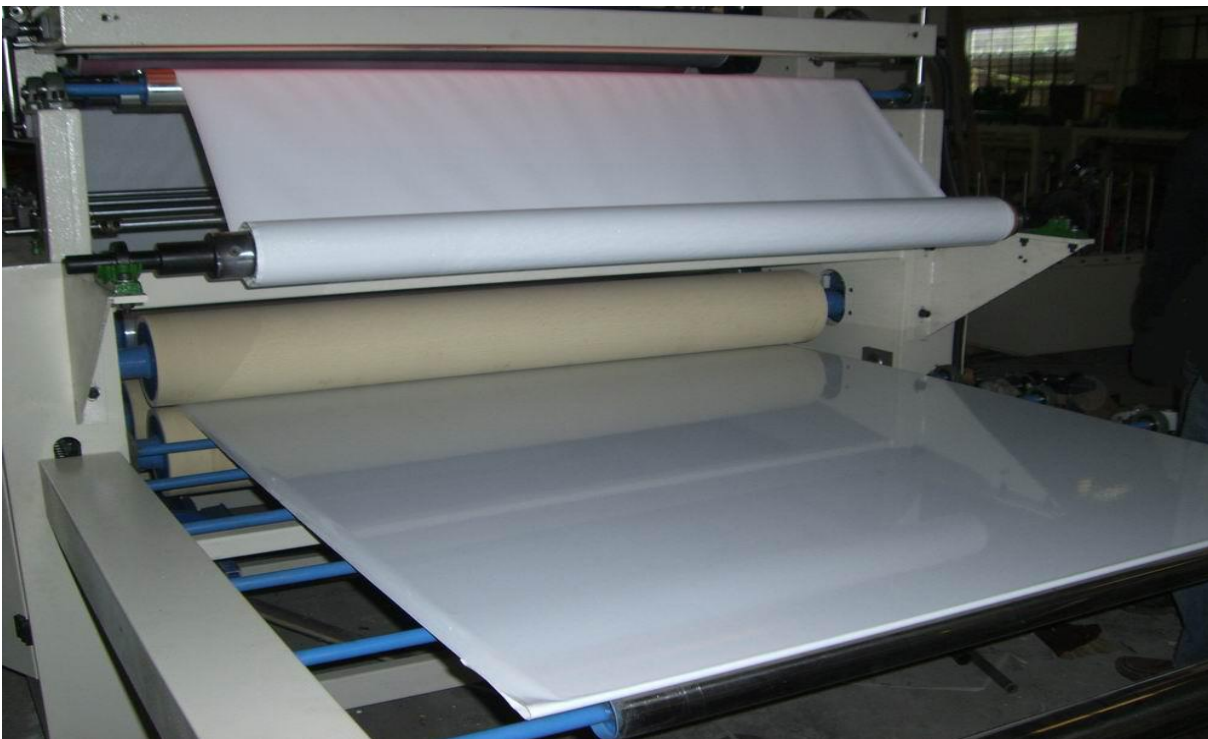

This machine is specially designed for sticking all kinds of decorative paper and pvc film on plain MDF board,chipboard and plywood.

This machine is specially designed for large sized furniture manufacturers.the production capacity is 2000 boards per day (8 working hours).

Functions: Dust collection,glue spreading equipment,paper sticking equipment and press equipment.

2.Raw materials:

A.All kinds of decorative paper and pvc film.

B.Plywood,particleboard,hardboard,MDF,Gypsum board

C.PVAC glue,latex glue

Technical Specification

Mode specification	Ø190×1350mm	Motivity power	7kw
Min.Board length	600mm	Heating power	8kw
Board width	1220mm	Paper width	1280mm
Board thickness	2-30mm	Overall Dimensions	16000×1900×1700mm
Feeding speed	1-18m/min	Machine weight	5000kg
Principal axis roller diameter	Ø190		

Machine conveyor picture:

1. Machine dust clean and glue spreader:

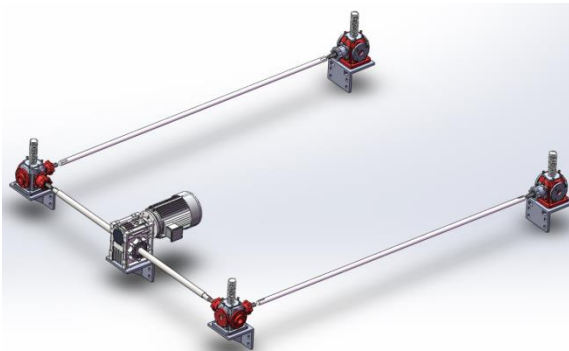
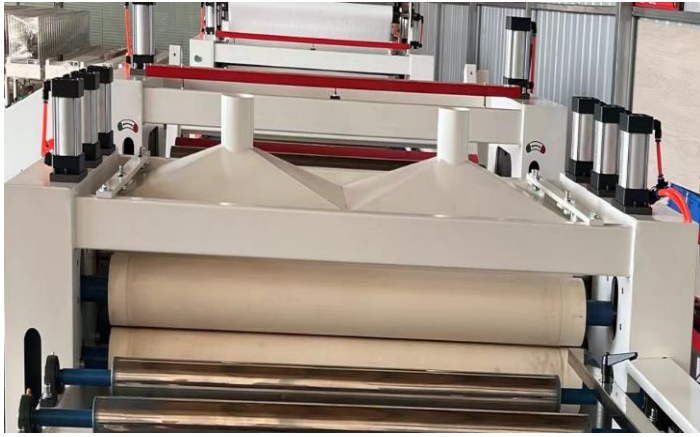

2. Paper sticking machine

2.1, the use of integrated structure, holding stable, convenient installation and

simple operation.

2.2, feeding power: 1.5kw, electric lifting power: 0.55kw.

2.3, the lifting adopts four worm gear continuous lifting, stable and high accuracy.

2.4, frequency control, line speed: 0-16 m/min, production beat according to the field glue, temperature test.

2.5, the material of the rubber roller is silicone rubber roller, suitable for a wider scope of glue, rubber roller specification: 190*1350mm.

2.6, the pressure is pneumatic.

2.7, thickness display.

2.8. With press roller before and after dust removal.



3. Paper repress machine

3.1, feeding power: 1.5kw, electric lifting power: 0.55kw.

3.2, the lifting adopts four worm gear continuous lifting, stable and high accuracy.

3.3, frequency conversion speed regulation, line speed is: 0-16 meters/min, the production beat according to the field glue, temperature test.

3.4, the first group of roller for the silicone roller, the second, three, four, five groups of roller for heating roller, the bottom roller is all steel roller, roller specifications: 190*1350mm.

3.5, equipped with 1 ton paper lifting device, the maximum diameter of the film roll is 600mm, with two 150*300mm extension shaft.

3.6, lift for the press roller, the bottom roller does not move.

3.7, the first group of roller force, speed and bottom roller matching.



