

UNPACK THE INNOVATIVE TECHNOLOGIES
SPINNER 450 S



Edda Spinner series of Horizontal Stretch Wrapping Machine with various models are well-known as the best solutions of packaging needs.

All models are equipped with the latest technology. By the durable mechanical structure and required systems for operator safety, this machines compliance with European Union safety directives and are certified with CE Certificate. All standard components which used in machine are the best in their field as worldwide trademarks.

These machines are developed for a long and trouble-free servicing life and are produced with well-know, best quality components by our qualified staff.

Edda Spinner Series packing machines are intended for easy packing of the products by the PE bubble nylon, PE foam film and PE stretch film materials.

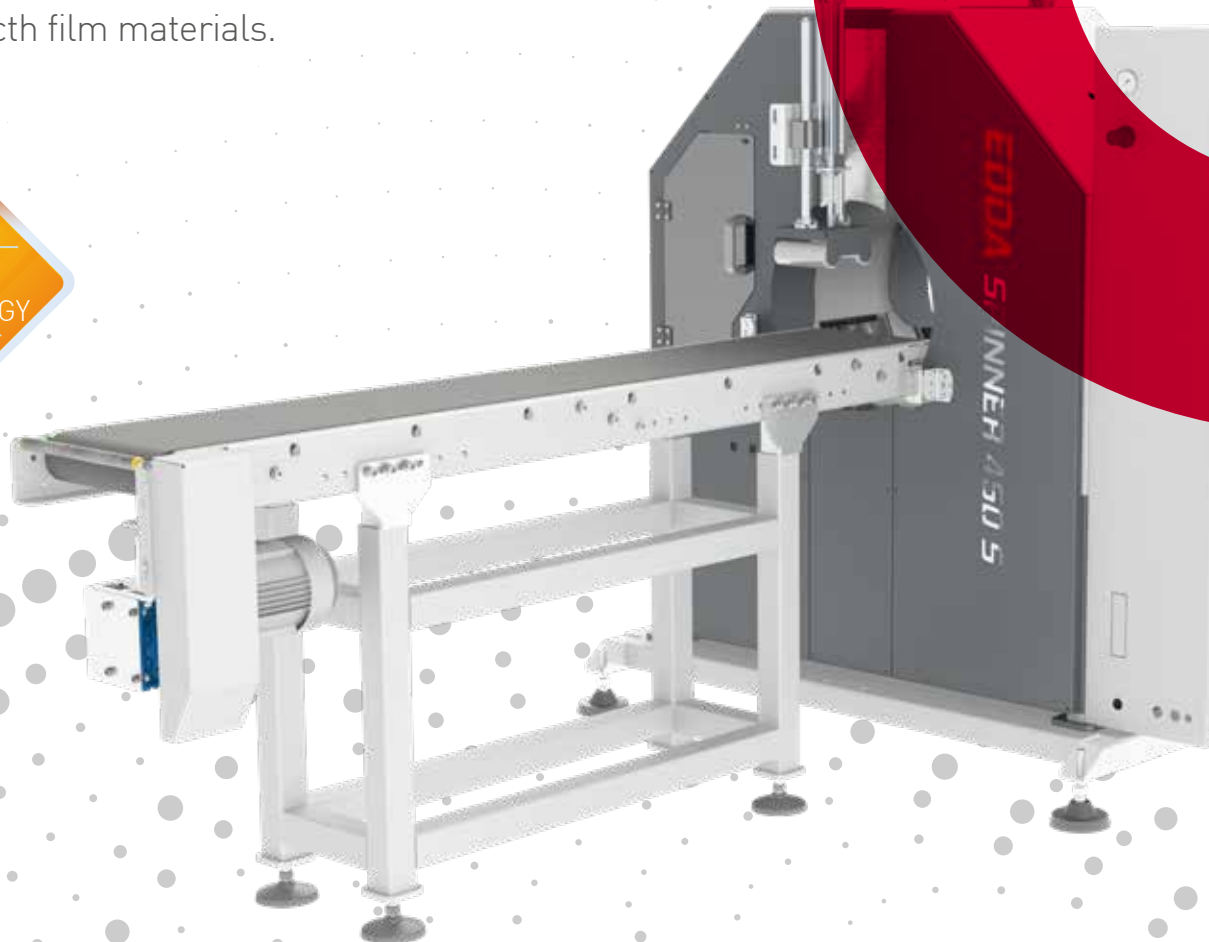

TECHNICAL FEATURES

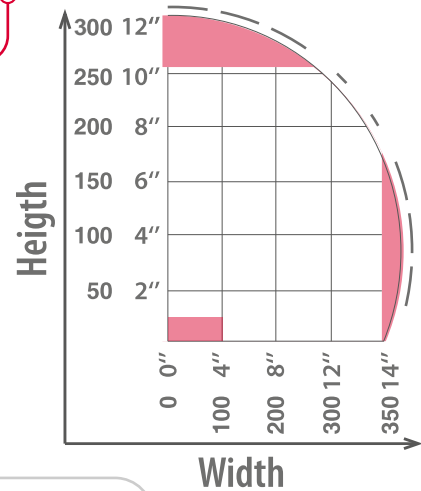

CONVEYOR BELT'S FEATURES

Useful Length	mm/inch	1820	71 ²¹ / ₃₂ "
Total Length	mm/inch	2000	78 ⁶⁷ / ₆₄ "
Working Height	mm/inch	901	35 ¹⁵ / ₃₂ "
Electric Motor Power	kW	0,55	
Max. Conveyor Speed	meter/min.	15	
Max. Load Capacity	kgs/meter	100	

PRODUCT TO WRAP SIZES

Max. Length		Unlimited
Min. Dimensions (Width x Height x Length)	mm/inch	100 x 18 x 600* 3 ¹⁵ / ₁₆ " x 4 ⁵ / ₆₄ " x 23 ⁵ / ₈ " * With Short Part Nail

STRETCH FILM FEATURES

Max. Width	mm/inch	170	6 ¹¹ / ₁₆ "
Max. Diameter	mm/inch	Ø 230	9 ¹ / ₁₆ " (Max. Weight: 3 kg.)
Reel Core Diameter	mm/inch	Ø 76	2 ⁶⁹ / ₆₄ "
Recommended Thickness	micron	23, 30, 35	

MACHINE GENERAL FEATURES

Main Motor Power	kW	1,1
Max. Ring Rotation Speed	rpm	160
Min. Ring Rotation Speed	rpm	40
Standard Machine Dimensions (W X H X L)	mm/inch	1571 x 1593 x 4220 61 ²⁷ / ₃₂ " x 62 ¹¹ / ₁₆ " x 166 ⁹ / ₆₄ "
Total Weight	kg	590
*Electric Supply	Volt - Hz	380 Volt - 50/60 Hz - 3P + 1N + 1G
Total Power	kW	2,3

* 208 Volt, 380 Volt, 415 Volt, 480 Volt 50/60 Hz (optional)

The machine is equipped with improved component that allow the machine to work accurately, without failure and for a long time.



Stretch Film Cutting Unit



Stretch Film Carriage Unit



Top Press



Motorized Conveyors



Foot Pedal Switch

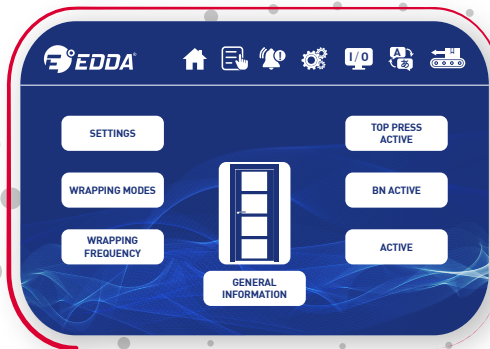

HMI Touch Panel

DO YOU
know which
equipment is
included

Some useful optional equipment. You can search for more with us.



Heavy Duty Roller Conveyor
Motorized / Non - motorized



Pneumatic Lifter Conveyor



Fork - Lift Reel Table

DO YOU
need any
optional
equipment



Scissor Lift Roller Table



Different Length Motorized Conveyor



Manuel Side Guide



Non - Motorized Reel Conveyor

DO YOU
need any
optional
equipment



Double stretch film cartridge



Automatic Centering
Side Press



Labeling Conveyor

DO YOU
need any
optional
equipment

Keep your products in safe!

Flexible and universal packaging solutions for many industries. From small productions to huge manufacturing areas. Our team will help you to search the optimal equipment for your production needs.



Automotive Spares



Wood



Profile



Metal



Parquet



Pvc Profile



Door jamb



WHICH
sector
is yours

Advantage contents applicable to carton box machine.



Productivity;

Provides reduction in energy consumption and cost of packaging materials.



Practicality;

User-friendly touch panel has 5 different operating modes and recipes.



Ergonomics;

It provides easy adjustment of the machine parameters by touch panel screen.



Protection;

Optimal protection of products from external factors, reducing damages during transportation.



Immutability;

It provides an uniform shape of the packaging standard for all products.



Flexibility;

It allows to pack workpieces with different heights, lengths and thickness.



Strength;

It contains the long-lasting parts for serial usage and operation.

WHAT
are the
main
advantages

All around the world

We have strong references and partners in many countries who provide all technical service, installation, training and spare part support. Our main principle is provide the immediate support.

We are servicing at

5
CONTINENTS

WHERE

we
are



 Büyükbalıklı Mah. 1. Ayça Sokak
No: 6, 16110, Nilüfer / BURSA / TÜRKİYE

 +90 850 308 67 41

 info@eddapack.com

www.eddapack.com 



0523