



WEIGHING & INSPECTING

PRODUCT CATALOG



Search 'Easyweigh Equipment' in social media.

Website: www.easyweigh-group.com

Email: sales@easyweigh-group.com

Tel: +86-760-8996 3400

Add: No.11 Lianmin Road, Torch Development Zone, Zhongshan, Guangdong, China

GUANGDONG EASYWEIGH EQUIPMENT CO., LTD.

- Dynamic Checkweigher
- Weight Grader
- Metal Detector
- X-Ray Inspection System
- Combination Weigher

X-Ray Inspection System For Packaged Products

Suitable for foreign object detection of all food, medicine, light industry and various packaging products

Model FXR-4017 FXR-6035

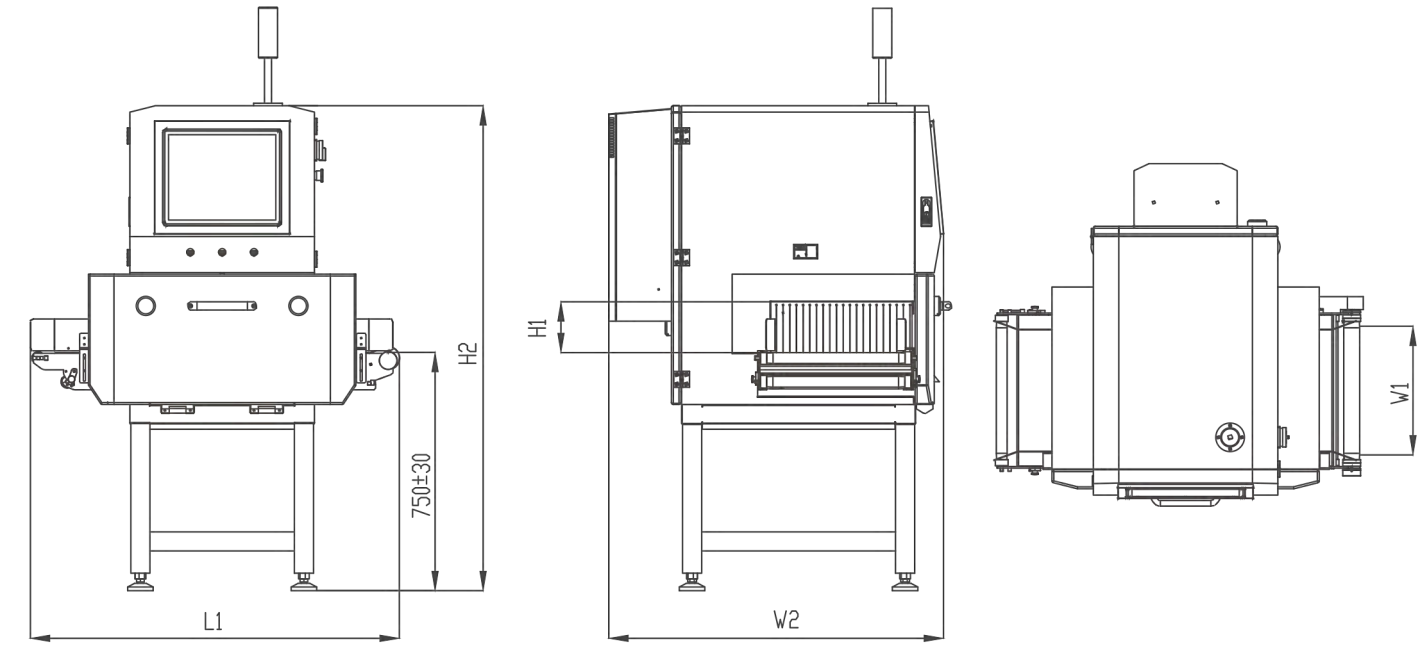

Model	Size (mm)	W1	H1	W2	H2	L1
FXR-4017		425	160	1070	1580	1144
FXR-6035		625	350	1250	1680	1290

Application snacks, baby food, seasoning, solid drinks, etc

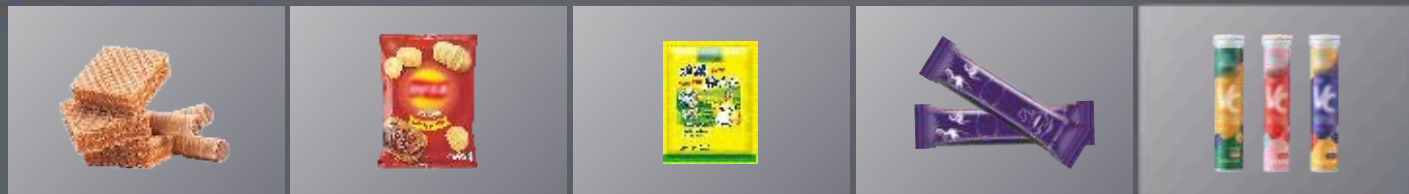

Detailed parameter

Model	FXR-4017	FXR-6035
X-Ray Tube	40-120KV	40-120KV
Aperture Size	Width	600mm
	Height	350mm
Working Speed	10-100m/min	
Sensitivity	Stainless Steel Ball	Φ0.3mm
	Stainless Steel Wire	Φ0.2*2mm
	Ceramic	Φ1.0mm
	Glass	Φ1.0mm
Operation	17-inch colored touch screen, Windows System	
Support data interface	LAN Port, USB Port	
Power Supply	AC220V±10% 50Hz/60Hz, 1.5KVA Max	
Rejector	Sound and indicator/stopping machine/rejector	
Waterproof Level	IP66 for tunnel, IP54 for rest part	
Operating Requirement	Temperature: -10°C ~ 40°C, Humidity: 30% ~ 95%	
Main Structure	SUS304 Stainless Steel	

X-Ray Inspection System For Unpackaged Bulk Products

Suitable for loose and unpackaged materials such as nuts, oatmeal, wheat, rice and other grains, candies, capsules, tablets, rubber particles, etc.

Model FXR-S4017 FXR-S6035

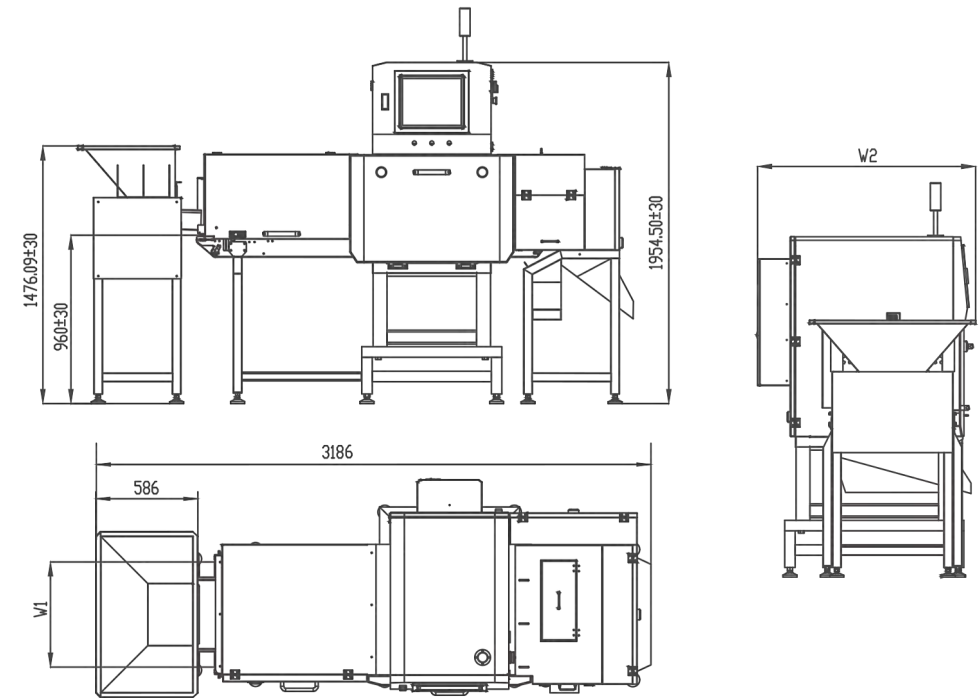

Size (mm)	Model	FRX-S4017	FRX-S6035
W1		405	605
W2		1451	1251

Detailed parameter

Model		FXR-S4017	FXR-S6035
X-Ray Tube		40-120KV	40-120KV
Aperture Size	Width	400mm	600mm
	Height	170mm	350mm
Working Speed		10-100m/min	
Sensitivity	Stainless Steel Ball	Φ0.3mm	
	Stainless Steel Wire	Φ0.2*2mm	
	Ceramic	Φ1.0mm	
	Glass	Φ1.0mm	
Operation		17-inch colored touch screen, Windows System	
Support data interface		LAN Port, USB Port	
Power Supply		AC220V±10% 50Hz/60Hz/, 1.5KVA Max	
Rejector		Air blast, single/double/four-lane flipper	
Waterproof Level		IP66 for tunnel, IP54 for rest part	
Operating Requirement		Temperature: -10°C ~ 40°C, Humidity: 30% ~ 95%	
Main Structure		SUS304 Stainless Steel	

Application oatmeal, nuts, rice, candies, rubber particles, etc.



Single Beam Side Scan X-Ray Inspection System

With a unique design for the vertical state of the bottle, cans, boxes, and other products' foreign body detection.

Model FXR-C180

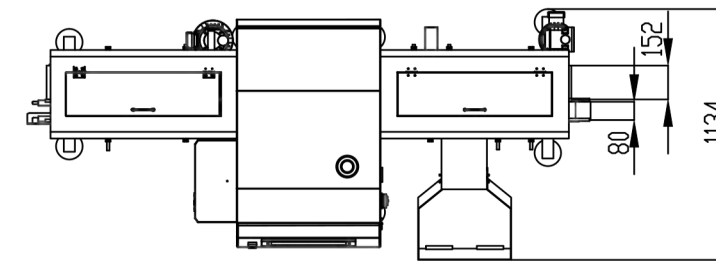
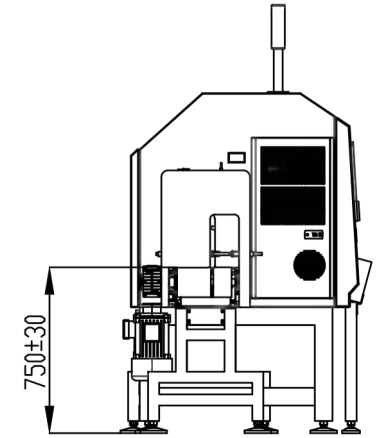
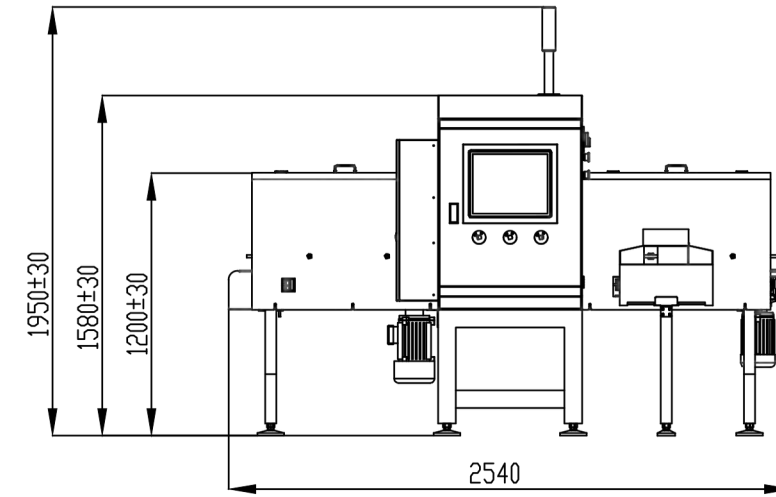

Detailed parameter

Model		FXR-C180
X-Ray Tube		40-120KV
Aperture Size	Width	180mm
	Height	250mm
Working Speed		10-100m/min
Sensitivity	Stainless Steel Ball	Φ0.3mm
	Stainless Steel Wire	Φ0.2*2mm
	Ceramic	Φ1.0mm
	Glass	Φ1.0mm
Operation		17-inch colored touch screen, Windows System
Support data interface		LAN Port, USB Port
Power Supply		AC220V±10% 50Hz/60Hz, 1.5KVA Max
Rejector		Sound and indicator/stopping machine/rejector
Waterproof Level		IP66 for tunnel, IP54 for rest part
Operating Requirement		Temperature: -10°C ~ 40°C, Humidity: 30% ~ 95%
Main Structure		SUS304 Stainless Steel

Application bottled and canned drinks, formula milk, bottled seasoning, etc.



Dual Beam Side Scan X-Ray Inspection System

It is suitable for the all-around detection of foreign objects in a vertical state in bottles, cans, boxes, and other products.
Using two vertical 90° cross-type light sources. That can effectively avoid blind spots by scanning products from two different angles.

Model FXR-C180-2



Application bottled and canned drinks, formula milk, bottled seasoning, etc.

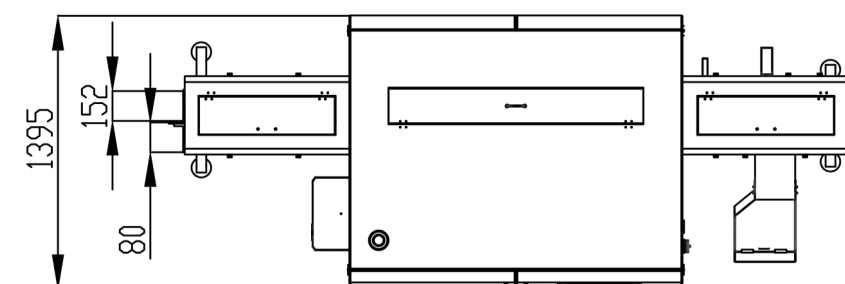
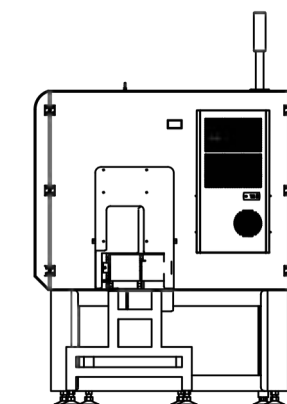
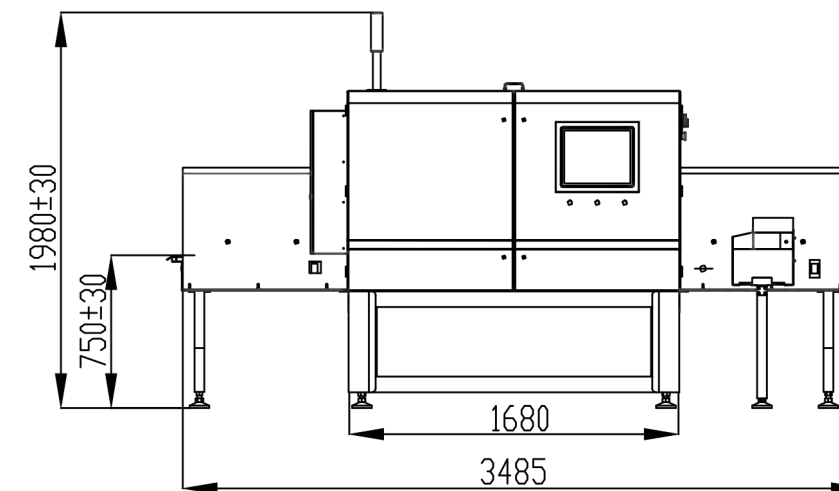

Detailed parameter

Model	FXR-C180-2	
X-Ray Tube	40-120KV	
Aperture Size	Width	180mm
	Height	250mm/350mm
Working Speed	10-100m/min	
Sensitivity	Stainless Steel Ball	Φ0.3mm
	Stainless Steel Wire	Φ0.2*2mm
	Ceramic	Φ1.0mm
	Glass	Φ1.0mm
Operation	17-inch colored touch screen, Windows System	
Support data interface	LAN Port, USB Port	
Power Supply	AC220V±10% 50Hz/60Hz, 1.5KVA Max	
Rejector	Sound and indicator/stopping machine/rejector	
Waterproof Level	IP66 for tunnel, IP54 for rest part	
Operating Requirement	Temperature: -10°C ~ 40°C, Humidity: 30% ~ 95%	
Main Structure	SUS304 Stainless Steel	