

GLOBAL TPE SEALING SOLUTIONS

WOODEN DOOR & WINDOW SYSTEM GASKETS





Conte

Conta



GLOBAL TPE SEALING SOLUTIONS

CNT Conta

Flexible Products

Conta Elastik Ürünler San. ve Tic. A.Ş. was established in 2004 in Gebze (Turkey) in order to meet customer demands and needs with the right products along with state of the art manufacturing facility. Since its inception, Conta has established its goal to be customer-oriented which is abridged in our business motto – Flexible Products.

Owing to Conta's excellent product quality and service, it is now the leading manufacturer of Thermoplastic Elastomer (TPE) based gaskets with production plants in Turkey, China and the USA.

Conta manufactures a wide variety of sealing products ranging from PVC window profiles, aluminum profiles, wooden door/ window profiles, white goods, refrigerators, pipe clamps, tool boxes, food containers to transport trailers.

In Conta, we strive to provide the best customer experience.



Production Plants

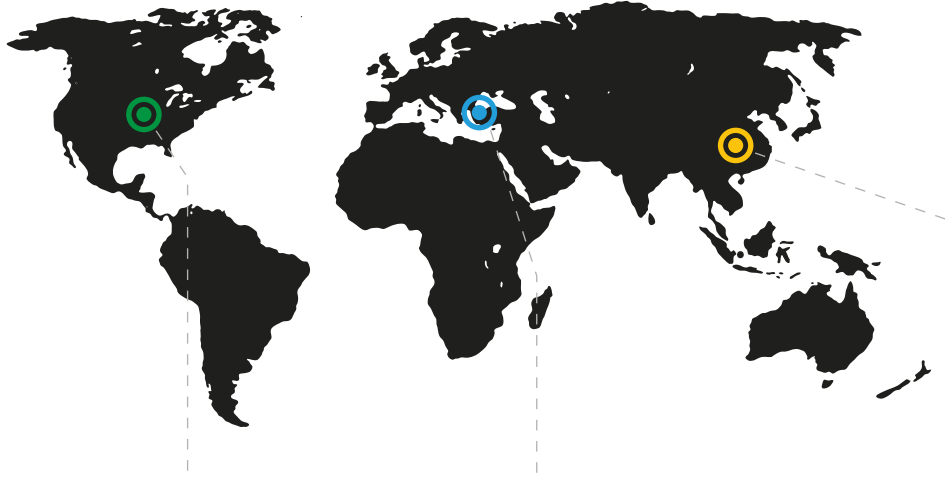

Conta North America Inc.
Gainesville, GA , USA

2.000 m² indoor area
The annual production capacity:
50 million meters



Conta Elastik Ürünler San. ve Tic. A.Ş.
Gebze, Kocaeli, Turkey

17.500 m² land
6.500 m² indoor area
The annual production capacity:
350 million meters



Ningbo Conta Sealing Products Co. Ltd
Xiaogang, Beliu District, Ningbo, China

2.500 m² indoor area
The annual production capacity:
50 million meters



History

- 2004** — Conta started to produce TPE extrusion products in Pulver Kimya.
- 2005** — Conta established its molding department.
- 2006** — Conta decided to continue its activities as "CNT Conta Elastik Ürünler San. And Tic. A.Ş." San. And Tic. A.Ş.
- 2006** — Conta made its first export to Bulgaria.
- 2006** — Conta entered white goods sector.
- 2008** — Conta started investing in refrigerator sector.
- 2010** — Conta moved to its state-of-the-art facility in Gebze.
- 2010** — Conta started selling gaskets for refrigerators.
- 2013** — Conta began exporting gaskets to Chinese PVC profile producer.
- 2013** — Conta setup its R&D center.
- 2013** — Conta decided to build a production unit in China.
- 2013** — Conta signed an agreement with an American partner.
- 2014** — Conta started production under the name "Ningbo Conta Industries Co. Ltd." in Ningbo, China.
- 2014** — Conta started production as "Conta North America Inc." in Imlay City, Michigan, USA.
- 2015** — Conta acquired 100% ownership of "Ningbo Conta Industries Co. Ltd."
- 2016** — Conta commenced its new production facility at Gebze Organize Sanayi Bölgesi (GOSB), Tembelova.
- 2016** — Conta started selling pipe clamp, toolbox cover and trailer gaskets.

Research and Development



Our goal is to manufacture the most accurate design in the shortest possible time without overloading the Tooling Department. Therefore, our Tooling Department is divided into three sections. First, the design office prepares gasket design according to customer's data. Once the design is approved by our customer, drawings are transferred to the workshop section where respective molds are made using CNC machines. Molds are then delivered to test section where samples are produced and sent to the customer after inspection. Finally, molds approved by the customer are handed over to Production Department.

Our R&D Department works continuously to improve production efficiency and gasket quality. Latest designs and extensive research not only allows customers access to outstanding products at competitive prices but also adds value to the sector.

SGS

TEST REPORT Job No./Report No TR1113264

CONTA ELASTİK ÜRÜNLER A.Ş.
GOSB TEMBELOVA 3400 SOKAK NO:3401 GEBZE 41400 KOCAELI
TEL:+905434567816
FAX:+902626429990

Classification and direct field of application:

This classification has been carried out in accordance with **EN 13501-1:2007+A1:2009**.

Classification:

Fire behaviour		Smoke production			Flaming droplets	
E	—	s	-	,	d	-

Reaction to fire classification: E

Product Coding System

[CNT S F 7040 16 000]

RAW MATERIAL

S(SEBS)
V(TPV)

DESIGN
YEAR

COUNTER

APPLICATION

R(Regular)
F(Foam)
C(Core)

COLOR

Grey (RAL 7040)
White (RAL 9016)
Brown (RAL 8002)
Black (RAL 9004)
Beige (RAL 1001)

The coding system of our products is designed to show the used material, application type, color and design year.



NOTE: Colors shown above are indicative only, actual colors may vary.

PRODUCT CODE	COLOR	PACKAGING QUANTITY(mt/ box)	PACKING TYPE
CNT-SR-7040-16001	GREY	350	M10 Roll
CNT-SR-9016-16001	WHITE	350	M10 Roll
CNT-SR-8002-16001	BROWN	350	M10 Roll
CNT-SR-9004-16001	BLACK	350	M10 Roll
CNT-SR-1001-16001	BEIGE	350	M10 Roll

EN12365 Code: **W33661**

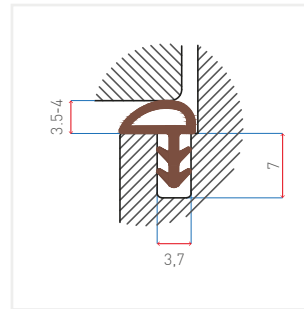

Application Drawing

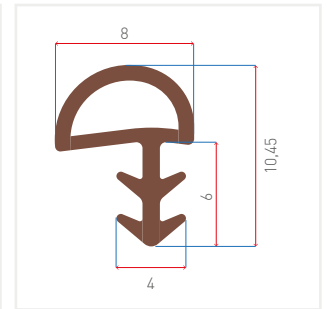

Technical Drawing

PRODUCT CODE	COLOR	PACKAGING QUANTITY(mt/ box)	PACKING TYPE
CNT-SR-7040-16002	GREY	300	M10 Roll
CNT-SR-9016-16002	WHITE	300	M10 Roll
CNT-SR-8002-16002	BROWN	300	M10 Roll
CNT-SR-9004-16002	BLACK	300	M10 Roll
CNT-SR-1001-16002	BEIGE	300	M10 Roll

EN12365 Code:

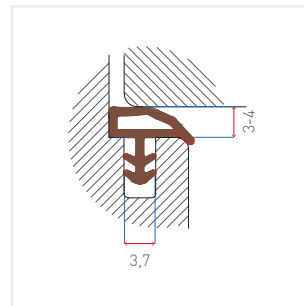

Application Drawing

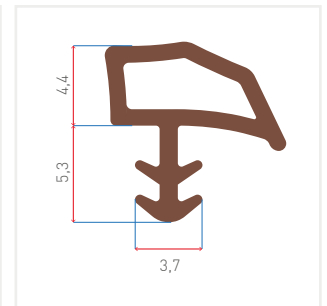

Technical Drawing

PRODUCT CODE	COLOR	PACKAGING QUANTITY(mt/ box)	PACKING TYPE
CNT-SR-7040-16003	GREY	150	M10 Roll
CNT-SR-9016-16003	WHITE	150	M10 Roll
CNT-SR-8002-16003	BROWN	150	M10 Roll
CNT-SR-9004-16003	BLACK	150	M10 Roll
CNT-SR-1001-16003	BEIGE	150	M10 Roll

EN12365 Code: **W33620**

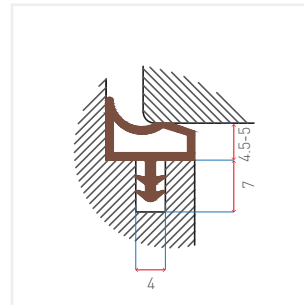

Application Drawing

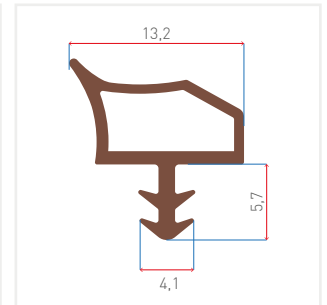

Technical Drawing

PRODUCT CODE	COLOR	PACKAGING QUANTITY(mt/ box)	PACKING TYPE
CNT-SR-7040-16021	GREY	150	M10 Roll
CNT-SR-9016-16021	WHITE	150	M10 Roll
CNT-SR-8002-16021	BROWN	150	M10 Roll
CNT-SR-9004-16021	BLACK	150	M10 Roll
CNT-SR-1001-16021	BEIGE	150	M10 Roll

EN12365 Code: **W33662**

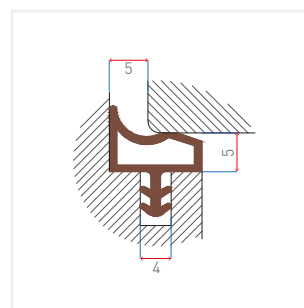

Application Drawing

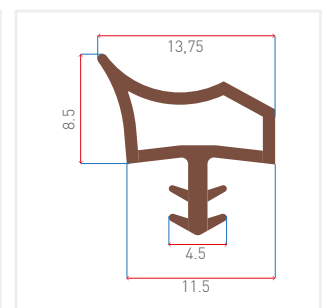

Technical Drawing

NOTE: Colors shown are indicative only, actual colors may vary.



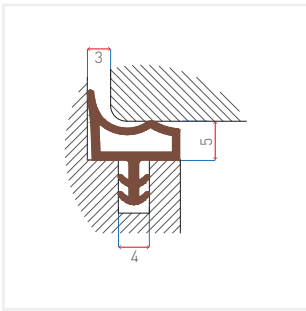

Application Drawing

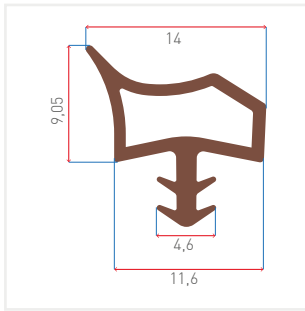

Technical Drawing

PRODUCT CODE	COLOR	PACKAGING QUANTITY(mt/ box)	PACKING TYPE
CNT-SR-7040-16023	GREY	150	M10 Roll
CNT-SR-9016-16023	WHITE	150	M10 Roll
CNT-SR-8002-16023	BROWN	150	M10 Roll
CNT-SR-9004-16023	BLACK	150	M10 Roll
CNT-SR-1001-16023	BEIGE	150	M10 Roll

EN12365 Code: **W33653**

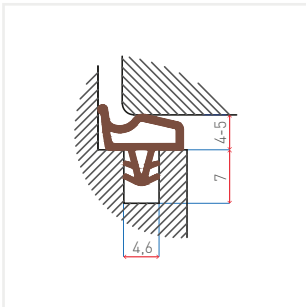

Application Drawing

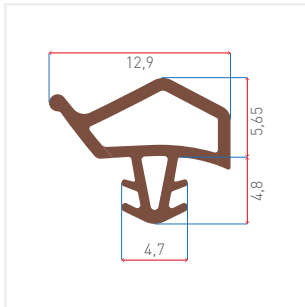

Technical Drawing

PRODUCT CODE	COLOR	PACKAGING QUANTITY(mt/ box)	PACKING TYPE
CNT-SR-7040-16012	GREY	200	M10 Roll
CNT-SR-9016-16012	WHITE	200	M10 Roll
CNT-SR-8002-16012	BROWN	200	M10 Roll
CNT-SR-9004-16012	BLACK	200	M10 Roll
CNT-SR-1001-16012	BEIGE	200	M10 Roll

EN12365 Code: **W33643**

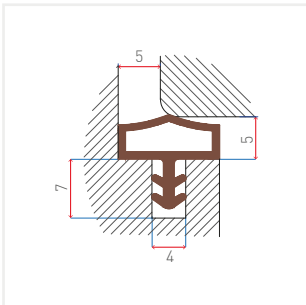

Application Drawing

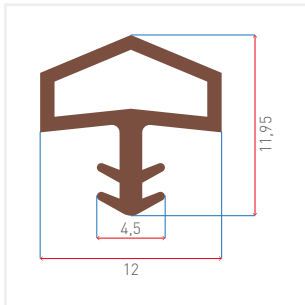

Technical Drawing

PRODUCT CODE	COLOR	PACKAGING QUANTITY(mt/ box)	PACKING TYPE
CNT-SR-7040-16020	GREY	200	M10 Roll
CNT-SR-9016-16020	WHITE	200	M10 Roll
CNT-SR-8002-16020	BROWN	200	M10 Roll
CNT-SR-9004-16020	BLACK	200	M10 Roll
CNT-SR-1001-16020	BEIGE	200	M10 Roll

EN12365 Code:

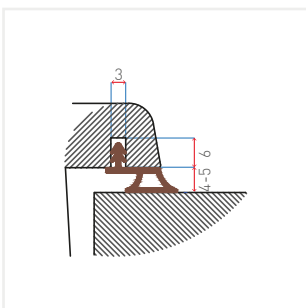

Application Drawing

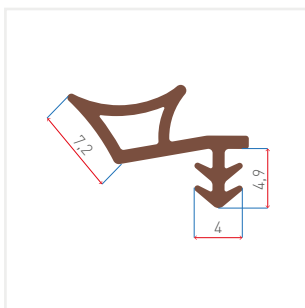

Technical Drawing

PRODUCT CODE	COLOR	PACKAGING QUANTITY(mt/ box)	PACKING TYPE
CNT-SR-7040-16011	GREY	250	M10 Roll
CNT-SR-9016-16011	WHITE	250	M10 Roll
CNT-SR-8002-16011	BROWN	250	M10 Roll
CNT-SR-9004-16011	BLACK	250	M10 Roll
CNT-SR-1001-16011	BEIGE	250	M10 Roll

EN12365 Code: **W33653**

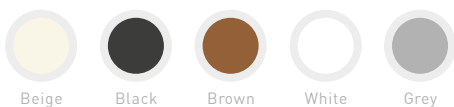

NOTE: Colors shown are indicative only, actual colors may vary.

PRODUCT CODE	COLOR	PACKAGING QUANTITY(mt/ box)	PACKING TYPE
CNT-SR-7040-16010	GREY	250	M10 Roll
CNT-SR-9016-16010	WHITE	250	M10 Roll
CNT-SR-8002-16010	BROWN	250	M10 Roll
CNT-SR-9004-16010	BLACK	250	M10 Roll
CNT-SR-1001-16010	BEIGE	250	M10 Roll

EN12365 Code: **W33620**

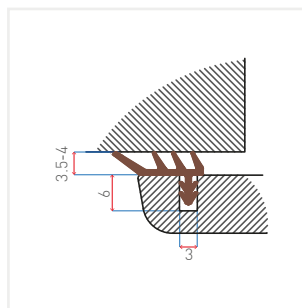

Application Drawing

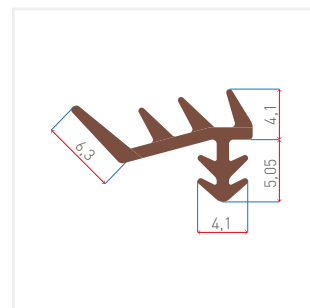

Technical Drawing

PRODUCT CODE	COLOR	PACKAGING QUANTITY(mt/ box)	PACKING TYPE
CNT-SR-7040-16004	GREY	500	M10 Roll
CNT-SR-9016-16004	WHITE	500	M10 Roll
CNT-SR-8002-16004	BROWN	500	M10 Roll
CNT-SR-9004-16004	BLACK	500	M10 Roll
CNT-SR-1001-16004	BEIGE	500	M10 Roll

EN12365 Code: **W43651**

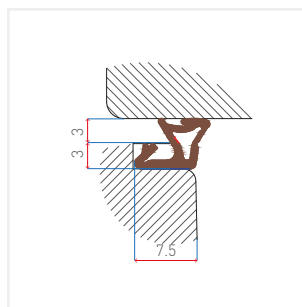

Application Drawing

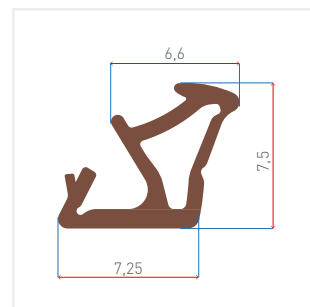

Technical Drawing

PRODUCT CODE	COLOR	PACKAGING QUANTITY(mt/ box)	PACKING TYPE
CNT-SR-7040-16016	GREY	450	M10 Roll
CNT-SR-9016-16016	WHITE	450	M10 Roll
CNT-SR-8002-16016	BROWN	450	M10 Roll
CNT-SR-9004-16016	BLACK	450	M10 Roll
CNT-SR-1001-16016	BEIGE	450	M10 Roll

EN12365 Code: **W43663**

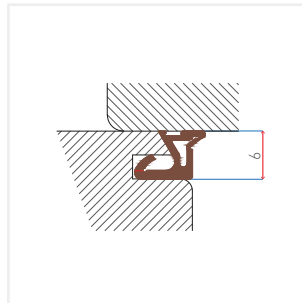

Application Drawing

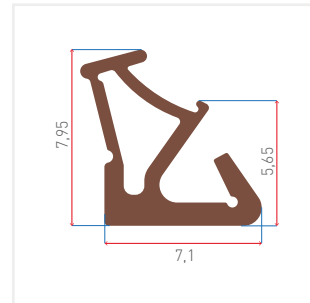

Technical Drawing

PRODUCT CODE	COLOR	PACKAGING QUANTITY(mt/ box)	PACKING TYPE
CNT-SR-7040-16024	GREY	500	M10 Roll
CNT-SR-9016-16024	WHITE	500	M10 Roll
CNT-SR-8002-16024	BROWN	500	M10 Roll
CNT-SR-9004-16024	BLACK	500	M10 Roll
CNT-SR-1001-16024	BEIGE	500	M10 Roll

EN12365 Code: **W43641**

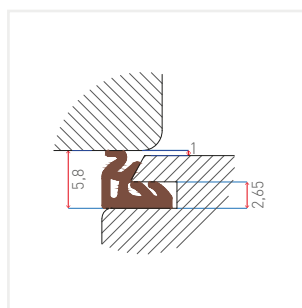

Application Drawing

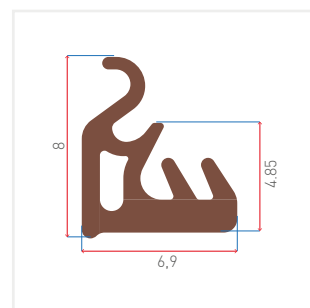

Technical Drawing

NOTE: Colors shown are indicative only, actual colors may vary.

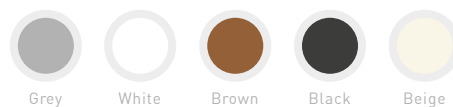

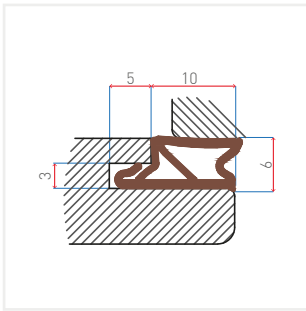

Application Drawing

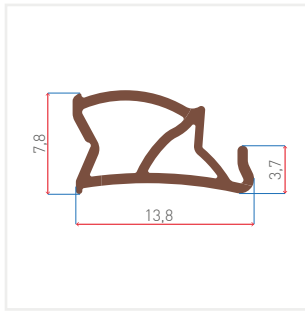

Technical Drawing

PRODUCT CODE	COLOR	PACKAGING QUANTITY(mt/ box)	PACKING TYPE
CNT-SR-7040-16009	GREY	250	M10 Roll
CNT-SR-9016-16009	WHITE	250	M10 Roll
CNT-SR-8002-16009	BROWN	250	M10 Roll
CNT-SR-9004-16009	BLACK	250	M10 Roll
CNT-SR-1001-16009	BEIGE	250	M10 Roll

EN12365 Code: **W42632**

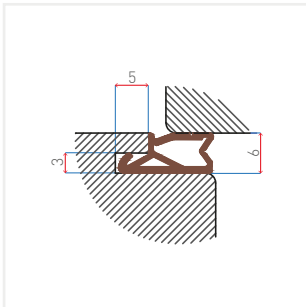

Application Drawing

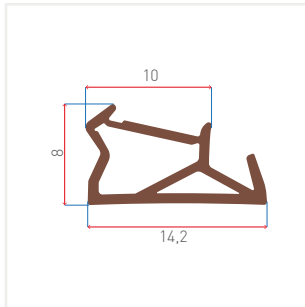

Technical Drawing

PRODUCT CODE	COLOR	PACKAGING QUANTITY(mt/ box)	PACKING TYPE
CNT-SR-7040-16006	GREY	250	M10 Roll
CNT-SR-9016-16006	WHITE	250	M10 Roll
CNT-SR-8002-16006	BROWN	250	M10 Roll
CNT-SR-9004-16006	BLACK	250	M10 Roll
CNT-SR-1001-16006	BEIGE	250	M10 Roll

EN12365 Code: **W33643**

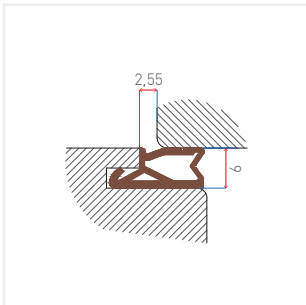

Application Drawing

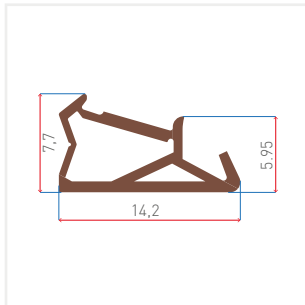

Technical Drawing

PRODUCT CODE	COLOR	PACKAGING QUANTITY(mt/ box)	PACKING TYPE
CNT-SR-7040-16018	GREY	250	M10 Roll
CNT-SR-9016-16018	WHITE	250	M10 Roll
CNT-SR-8002-16018	BROWN	250	M10 Roll
CNT-SR-9004-16018	BLACK	250	M10 Roll
CNT-SR-1001-16018	BEIGE	250	M10 Roll

EN12365 Code: **W43641**

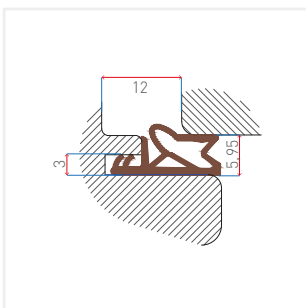

Application Drawing

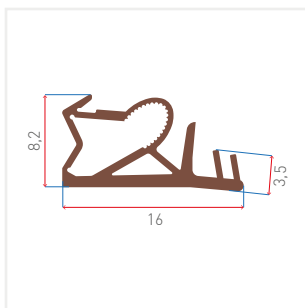

Technical Drawing

PRODUCT CODE	COLOR	PACKAGING QUANTITY(mt/ box)	PACKING TYPE
CNT-SR-7040-16019	GREY	200	M10 Roll
CNT-SR-9016-16019	WHITE	200	M10 Roll
CNT-SR-8002-16019	BROWN	200	M10 Roll
CNT-SR-9004-16019	BLACK	200	M10 Roll
CNT-SR-1001-16019	BEIGE	200	M10 Roll

EN12365 Code: **W33642**



NOTE: Colors shown are indicative only, actual colors may vary.

PRODUCT CODE	COLOR	PACKAGING QUANTITY(mt/ box)	PACKING TYPE
CNT-SR-7040-16014	GREY	200	M10 Roll
CNT-SR-9016-16014	WHITE	200	M10 Roll
CNT-SR-8002-16014	BROWN	200	M10 Roll
CNT-SR-9004-16014	BLACK	200	M10 Roll
CNT-SR-1001-16014	BEIGE	200	M10 Roll

EN12365 Code: **W33642**

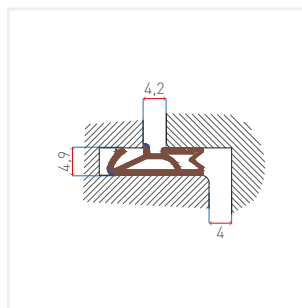

Application Drawing

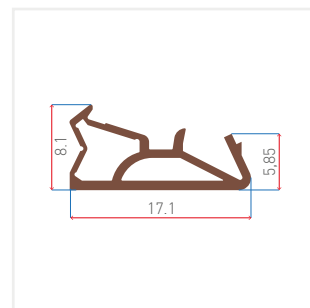

Technical Drawing

PRODUCT CODE	COLOR	PACKAGING QUANTITY(mt/ box)	PACKING TYPE
CNT-SR-7040-16007	GREY	200	M10 Roll
CNT-SR-9016-16007	WHITE	200	M10 Roll
CNT-SR-8002-16007	BROWN	200	M10 Roll
CNT-SR-9004-16007	BLACK	200	M10 Roll
CNT-SR-1001-16007	BEIGE	200	M10 Roll

EN12365 Code: **W43651**

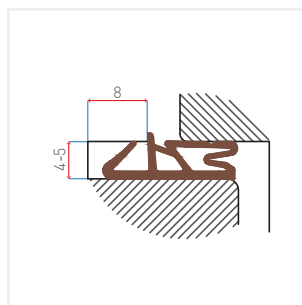

Application Drawing

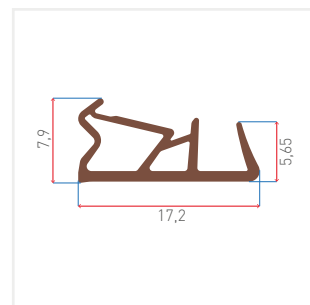

Technical Drawing

PRODUCT CODE	COLOR	PACKAGING QUANTITY(mt/ box)	PACKING TYPE
CNT-SR-7040-16005	GREY	200	M10 Roll
CNT-SR-9016-16005	WHITE	200	M10 Roll
CNT-SR-8002-16005	BROWN	200	M10 Roll
CNT-SR-9004-16005	BLACK	200	M10 Roll
CNT-SR-1001-16005	BEIGE	200	M10 Roll

EN12365 Code: **W33662**

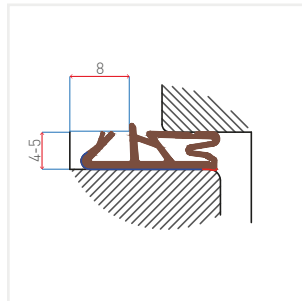

Application Drawing

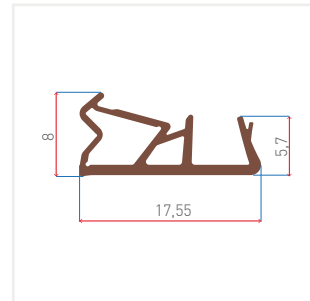

Technical Drawing

PRODUCT CODE	COLOR	PACKAGING QUANTITY(mt/ box)	PACKING TYPE
CNT-SR-7040-16013	GREY	200	M10 Roll
CNT-SR-9016-16013	WHITE	200	M10 Roll
CNT-SR-8002-16013	BROWN	200	M10 Roll
CNT-SR-9004-16013	BLACK	200	M10 Roll
CNT-SR-1001-16013	BEIGE	200	M10 Roll

EN12365 Code: **W43621**

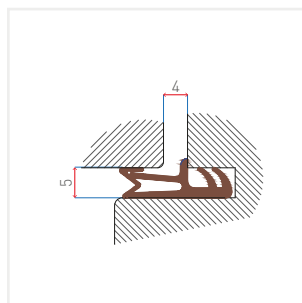

Application Drawing

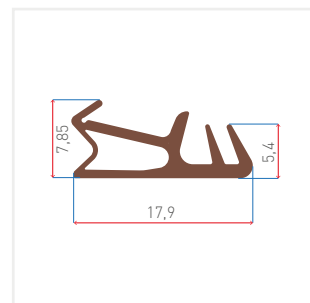

Technical Drawing

NOTE: Colors shown are indicative only, actual colors may vary.

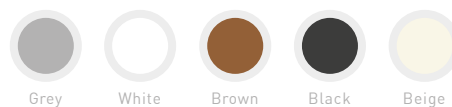

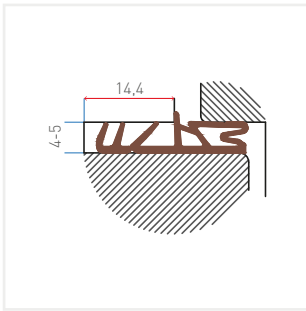

Application Drawing

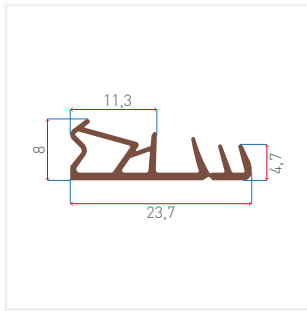

Technical Drawing

PRODUCT CODE	COLOR	PACKAGING QUANTITY(mt/ box)	PACKING TYPE
CNT-SR-7040-16008	GREY	150	M10 Roll
CNT-SR-9016-16008	WHITE	150	M10 Roll
CNT-SR-8002-16008	BROWN	150	M10 Roll
CNT-SR-9004-16008	BLACK	150	M10 Roll
CNT-SR-1001-16008	BEIGE	150	M10 Roll

EN12365 Code: **W33652**

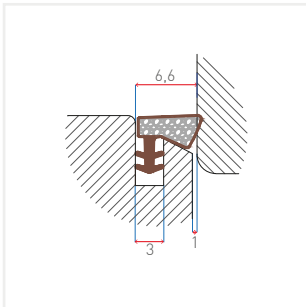

Application Drawing

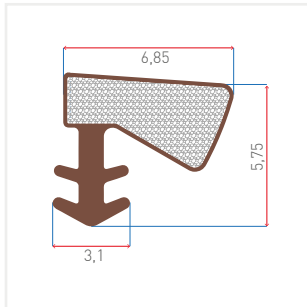

Technical Drawing

PRODUCT CODE	COLOR	PACKAGING QUANTITY(mt/ box)	PACKING TYPE
CNT-SF-7040-16022	GREY	600	M10 Roll
CNT-SF-9016-16022	WHITE	600	M10 Roll
CNT-SF-8002-16022	BROWN	600	M10 Roll
CNT-SF-9004-16022	BLACK	600	M10 Roll
CNT-SF-1001-16022	BEIGE	600	M10 Roll

EN12365 Code:

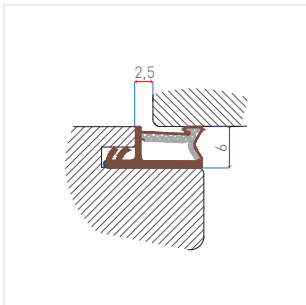

Application Drawing

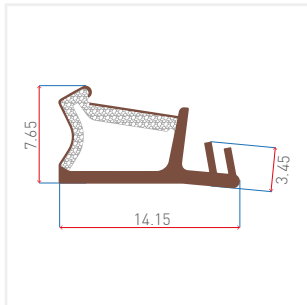

Technical Drawing

PRODUCT CODE	COLOR	PACKAGING QUANTITY(mt/ box)	PACKING TYPE
CNT-SF-7040-16017	GREY	250	M10 Roll
CNT-SF-9016-16017	WHITE	250	M10 Roll
CNT-SF-8002-16017	BROWN	250	M10 Roll
CNT-SF-9004-16017	BLACK	250	M10 Roll
CNT-SF-1001-16017	BEIGE	250	M10 Roll

EN12365 Code:

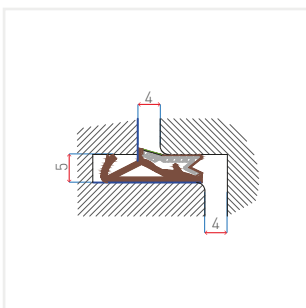

Application Drawing

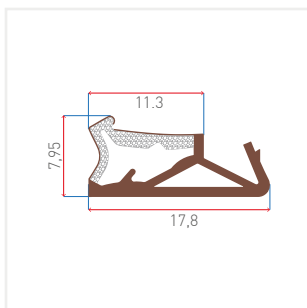

Technical Drawing

PRODUCT CODE	COLOR	PACKAGING QUANTITY(mt/ box)	PACKING TYPE
CNT-SF-7040-16015	GREY	200	M10 Roll
CNT-SF-9016-16015	WHITE	200	M10 Roll
CNT-SF-8002-16015	BROWN	200	M10 Roll
CNT-SF-9004-16015	BLACK	200	M10 Roll
CNT-SF-1001-16015	BEIGE	200	M10 Roll

EN12365 Code:

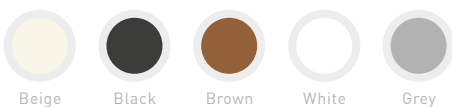

NOTE: Colors shown are indicative only, actual colors may vary.

Packing

measurements

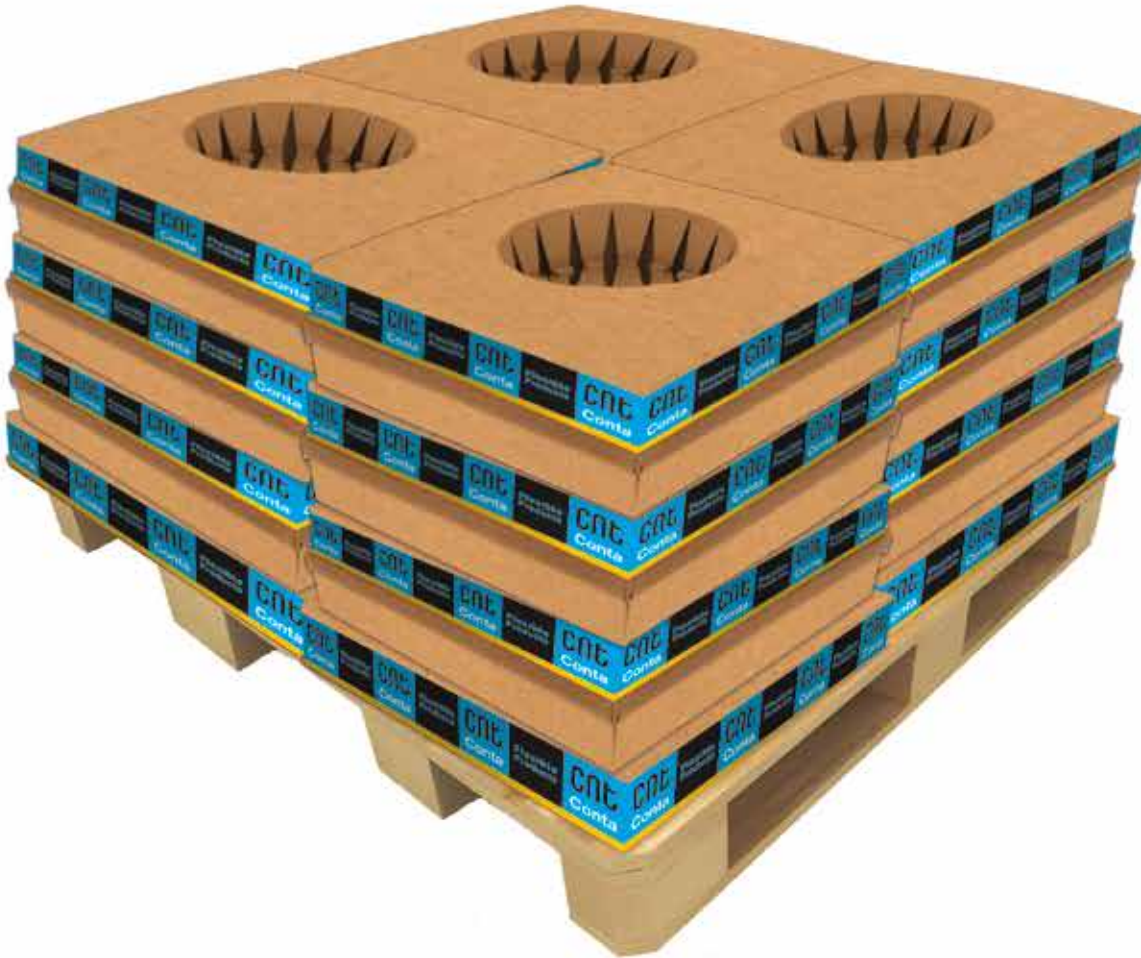

DIMENSIONS

BOX

Width: 57,5 cm
Length: 57,5 cm
Height: 18 cm

PALLET

Width: 110 cm
Length: 110 cm
Height: 260 cm



Cnt Wood Gaskets

Windows & Doors ◀

TPE based gaskets are preferred by wooden profile producers because of its lower compression set, higher strength and producibility in the same color like wood.

