

2 in 1 Honeycomb DEHUMIDIFIER

除湿干燥组合



TDD-300U/200H



露点计
(随机安装式)
Dewpoint Monitor
(Built-in)

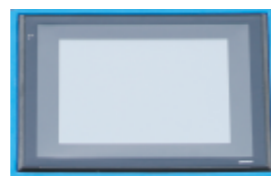

触摸屏控制面板
Touch Screen

产品特点 Features

- 邦普P.I.D温控系统、施耐德电控元件，精确控温质量可靠；
 - 日本陶瓷蜂巢搭配回风过滤器，露点可达-50°C；
 - 双冷却器结构，密闭式送料管路，高效除湿；
 - 双层保温桶设计，不锈钢料斗，整机全保温；
 - 下吹风管设计，旋风排气装置，防止热能流失，均匀分散热风，温度稳定；
 - 可选露点计、RS485通讯接口与液晶显示器，接入工业4.0。
- Brunp P.I.D temperature control system, Schneider electric components with accurate temperature and reliable quality.
 - Japanese ceramic honeycomb with return air filter, dew point can reach -50°C.
 - Two condensor, closed feeding lines, efficient dehumidification.
 - Double-layer insulated barrel design, stainless steel hopper for full insulation.
 - Hot air down-blowing design, cyclone air exhaust device to prevent heat loss and ensure it is heated evenly to maintain a steady temperature.
 - Optional dew points meter, R485 communication interface and LCD display, access to Industry 4.0.

外形尺寸 Outline Drawing

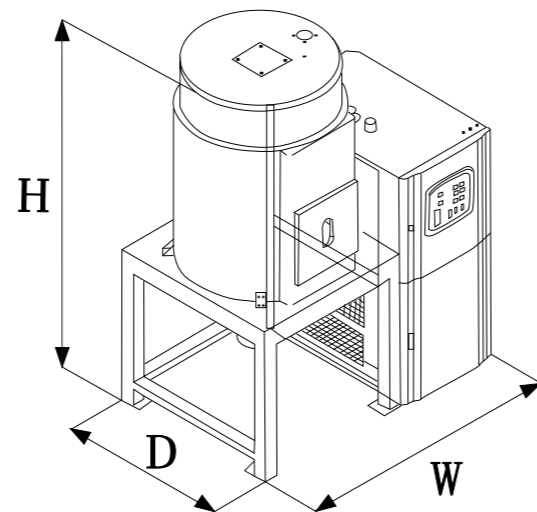

除湿干燥送料组合示意图

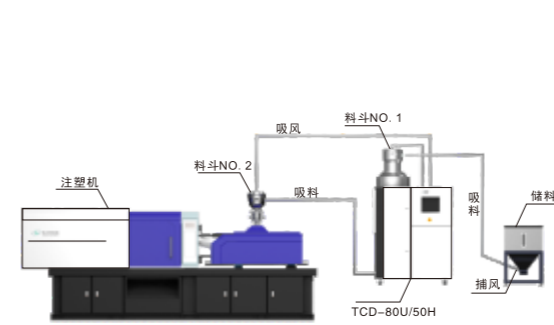

1对1 二段送料示意图(标准)
1To1 2-stage diagram

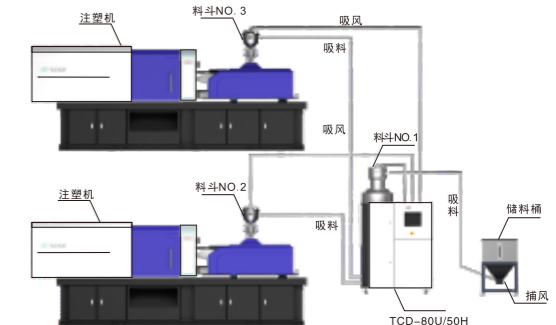

1对2 三段送料示意图(标准)
1To2 3-stage diagram

规格参数 Specifications

机型 Model	保温料桶容量 Drying Hopper capacity (L)	再生电热功率 Regen.Heater Power (kW)	再生风机功率 Regen.Blower Power (kW)	干燥电热功率 Process Heater Power (kW)	干燥风机功率 Process Blower Power (kW)	除湿风量 Dry Air Capacity (m³/hr)	外形尺寸(mm) Dimensions (HxWxD)	净重 Weight (KG)
TDD-2H0U/30	20	3	0.2	3	0.2	30	1845x883x1445	110
TDD-40U/30H	40	4	0.2	4	0.4	30	2299x999x1598	190
TDD-40U/50H	40	4	0.4	4	0.4	50	2299x999x1598	290
TDD-80U/50H	80	4	0.4	4	0.4	50	2310x1180x1773	210
TDD-120U/80H	120	6	0.4	6	0.85	80	2382x1180x1598	250
TDD-160U/80H	160	6	0.4	6	0.85	80	2633x1321x1598	255
TDD-160U/120H	160	6	0.4	6	0.85	120	2633x1321x1598	265
TDD-230U/120H	230	6	0.4	7	0.85	120	3176x1320x1803	295
TDD-230U/150H	230	6	0.85	7	1.6	150	3176x1320x1803	375
TDD-300U/150H	300	6	0.85	12	1.6	150	3211x1509x2175	410
TDD-300U/200H	300	7	0.85	12	1.6	200	3211x1509x2175	420
TDD-450U/200H	450	7	0.85	15	1.6	200	3150x1470x2175	550
TDD-450U/300H	450	7	0.85	15	3	300	3150x1470x2175	585
TDD-600U/300H	600	7	0.85	18	3	300	4427x1840x2568	615
TDD-600U/400H	600	7	0.85	18	4	400	4427x1840x2568	620
TDD-750U/400H	750	7	0.85	18	4	400	4527x1841x2570	650
TDD-750U/500H	750	12	1.6	18	3.7	500	4527x1841x2570	760
TDD-900U/500H	900	12	1.6	18	3.7	500	4909x2040x3036	820
TDD-900U/700H	900	12	1.6	18	3.7	700	4909x2040x3036	830
TDD-1200U/700H	1200	12	1.6	24	3.7	700	4718x2099x3112	870

机器电压规格为:3Φ,380V,50Hz。
Power:3Φ,380V,50Hz.

注:产品规格若有变更,恕不另行通知。
We reserve the right to change specifications without prior notice.

All in One Compact DRYER

除湿干燥送料组合

产品特点

Features

三机一体除湿干燥机广泛适用于各种塑料原料，尤其是吸湿性较强的工程塑料，如PA、PC、PBT、PET等。在理想状态露点可达-50°C，搭配台达高性能风机，根据生产需求提供二段送料(对应一台注塑机)或者三段送料(对应两台注塑机)的机型配置。

TCD Series "3 in 1" honeycomb dehumidifier integrated dehumidifying, drying and feeding into one unit, is widely used for all kinds of plastic materials. Especially engineering plastics with strong hygroscopicity, such as PA, PC, PBT, PET and so on. This machine has an ideal dew point of -50°C. With SINTD's high-performance motor. It is available in two-stage feeding (corresponding to one injection molding machine) or three-stage feeding (corresponding to two injection molding machines) configurations, depending on production requirements.



TCD-80U/50H

应用范例 Applications

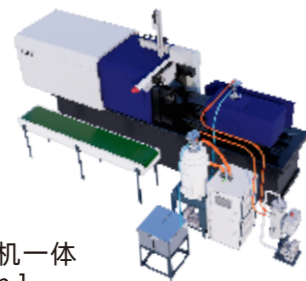

两机一体
2 in 1

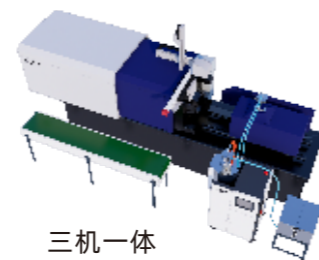

三机一体
all in one

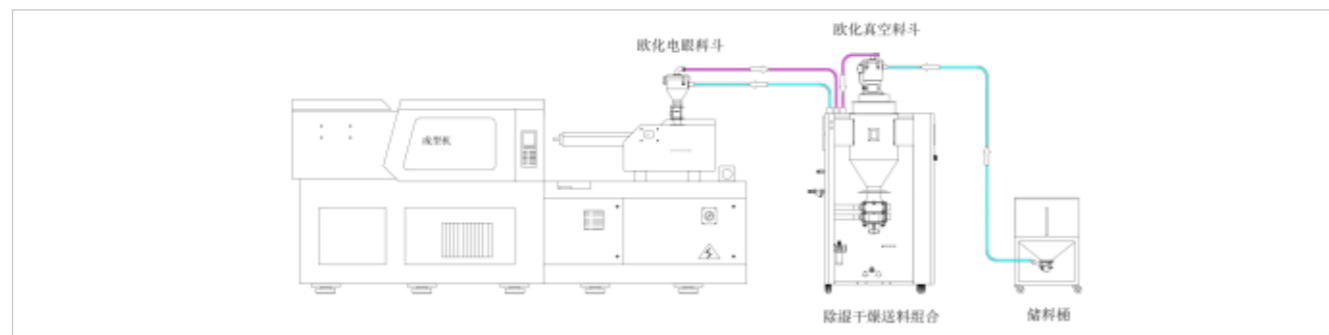

外形尺寸 Outline Drawing

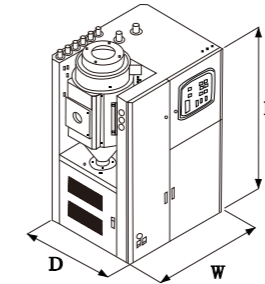

TCD全密闭式

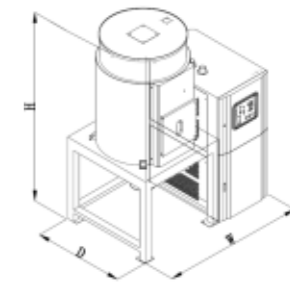

TCD半开放式

规格参数 (全密闭式)

Specifications (Fully-enclosed Design)

机型Model	TCD-20U/30H	TCD-40U/30H	TCD-40U50H	TCD-80U/50H	TCD-120U/80H	TCD-160U/80H	TCD-160U/120H	TCD-230U/120H	TCD-230U/150H	TCD-300U/150H	TCD-300U/200H	TCD-450U/200H
干燥系统 Drying System												
保温料桶容量 (L) Drying Hopper Capacity	20	40	40	80	120	160	160	230	230	300	300	450
干燥电热功率 (kW) Process Heater Power	3	3	4	4	6	6	6	7	7	12	12	15
干燥风机功率 (kW) Process Blower Power	0.4	0.4	0.4	0.4	0.85	0.85	0.85	0.85	1.6	1.6	1.6	1.6
除湿系统 Dehumidifying System												
再生电热功率 (kW) Regen.Heater Power	4	4	4	4	6	6	6	6	6	6	7	7
再生风机功率 (kW) Regen.Blower Power	0.2	0.2	0.4	0.4	0.4	0.4	0.4	0.4	0.4	0.4	0.4	0.85
除湿风量 (m³/hr) Dry Air Capacity	30	50	50	50	80	80	120	120	150	150	200	200
送料系统 Conveying System												
送料风机功率 (kW) Conveying Blower Power	0.85	0.85	0.85	1.6	1.6	1.6	1.6	1.6	1.6	1.6	1.6	1.6
吸料机配管 (inch) Dia. of Conveying Hose	1.5	1.5	1.5	1.5	1.5	1.5	1.5	1.5	1.5	1.5	1.5	1.5
THR-U-E料斗(L) THR-U-E Hopper Receiver	3	3	3	6	6	6	6	12	12	12	12	12
THR-U料斗(L) THR-U Hopper Receiver	3	3	3	6	6	6	6	12	12	12	12	12
外形尺寸 Dimensions												
H (mm)	1600	1600	1600	1600	1600	1600	1600	2380	2380	2380	2380	2380
W (mm)	810	810	810	810	810	810	810	980	980	980	980	980
D (mm)	1000	1000	1000	1000	1000	1000	1000	1380	1380	1380	1380	1380
净重 (Kg) Weight	305	325	335	325	345	385	505	515	540	560	565	595

规格参数 (半开放式)

Specifications (Semi-open Design)

机型Model	TCD-450U/300H	TCD-600U/300H	TCD-600U400H	TCD-750U/400H	TCD-750U/500H	TCD-900U6500H	TCD-900U/700H	TCD-1200U/700H
干燥系统 Drying System								
保温料桶容量 (L) Drying Hopper Capacity	450	600	600	750	750	900	900	1200
干燥电热功率 (kW) Process Heater Power	15	18	18	18	18	24	24	24
干燥风机功率 (kW) Process Blower Power	3	4	4	4	4	3.7	3.7	3.7
除湿系统 Dehumidifying System								
再生电热功率 (kW) Regen.Heater Power	7	7	7	7	15	15	15	15
再生风机功率 (kW) Regen.Blower Power	0.85	0.85	0.85	0.85	1.6	1.6	1.6	1.6
除湿风量 (m³/hr) Dry Air Capacity	300	300	400	400	500	500	700	700
送料系统 Conveying System								
送料风机功率 (kW) Conveying Blower Power	1.6	1.6	1.6	1.6	1.6	3	3	3
吸料机配管 (inch) Dia. of Conveying Hose	1.5	1.5	1.5	1.5	1.5	2	2	2
THR-U-E料斗(L) THR-U-E Hopper Receiver	12	12	12	12	12	24	24	24
THR-U料斗(L) THR-U Hopper Receiver	12	12	12	12	12	24	24	24
外形尺寸 Dimensions								
H (mm)	2480	2380	2380	2610	2760	2640	2640	3070
W (mm)	1490	1745	1745	1745	2140	2140	2140	2140
D (mm)	1255	1255	1255	1255	1380	1380	1380	1380
净重 (Kg) Weight	600	635	640	690	710	820	850	900

机器电压规格为:3Φ,380V,50Hz.
Power:3Φ,380V,50Hz.

注:产品规格若有变更,恕不另行通知。
We reserve the right to change specifications without prior notice.