



LUTZ FOLYO BIÇAK AĞIZLARI – YÜKSEK PERFORMANSLI FOLYOLARA ÜSTÜN NİTELİKLİ BIÇAK AĞIZLARI

ÖZEL BIÇAK AĞIZLARI

FOLYO

SENTETİK VE CAM ELYAF

TIBBİ MALZEME

GIDA MADDELERİ

ZANAAT / DIY

OTOMOBİL

DOKUMACILIK

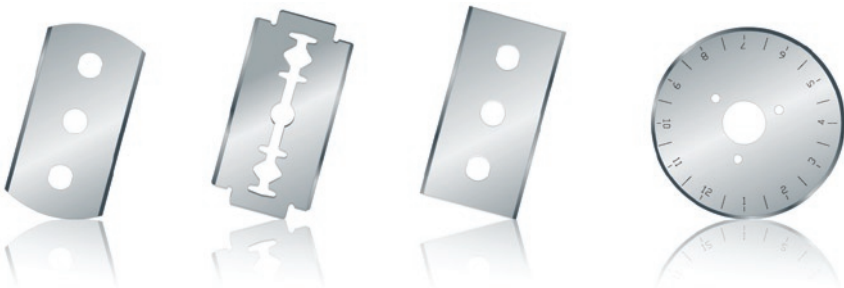







LUTZ FOLYO BIÇAK AĞIZLARI – YÜKSEK PERFORMANSLI FOLYOLARA ÜSTÜN NİTELİKLİ BIÇAK AĞIZLARI

Hem dirençli, hem esnek folyolar mı? İşlemede katkı maddeleri mi? Darbe yükü ve yan güçler mi? Folyo imalatı şüphesiz yüksek performanslı bir işlemdir.

LUTZ teknik amaçlara yönelik üstün nitelikli özel bıçak ağızları üretir. Biz çok çeşitli çelikler, karbitler ve keramikler kullanıyoruz.

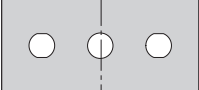
Bıçak ağızlarımız, ham madde, tavlama ve bıçak kenarı geometrileriyle kullanıcıların somut kesim amaçlarına göre ayarlanmıştır.

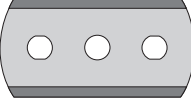
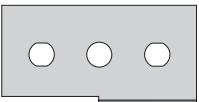
ÖZEL BIÇAK AĞIZLARI | FOLYO | SENTETİK VE CAM ELYAF | TIBBİ MALZEME | GIDA MADDELERİ | ZANAAT / DIY | OTOMOBİL | DOKUMACILIK

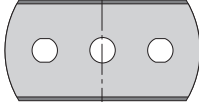
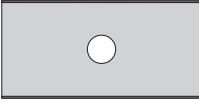
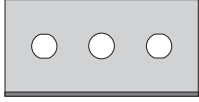
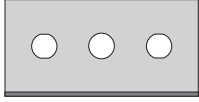
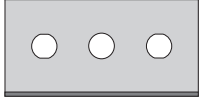
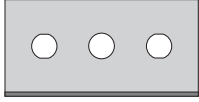
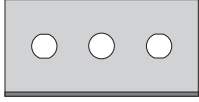
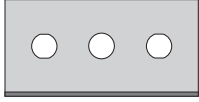
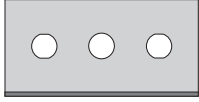
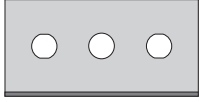
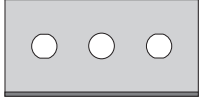
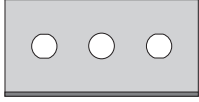
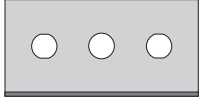
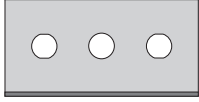
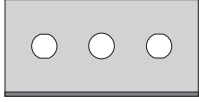
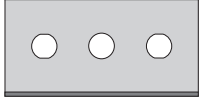
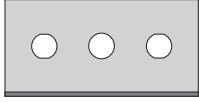
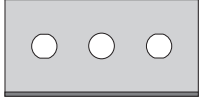
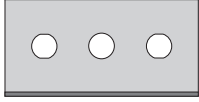
| Ürün No. | Boy (mm) | En (mm) | Kalınlık (mm) | Ürün No. | Boy (mm) | En (mm) | Kalınlık (mm) | Ürün No. | Boy (mm) | En (mm) | Kalınlık (mm) |
|---|----------|---------|---------------|---|----------|---------|---------------|---|----------|---------|---------------|
|  | 39,0 | 18,8 | 0,30 |  | 43,0 | 22,2 | 0,06 |  | 43,0 | 22,2 | 0,10 |
| 0310.0300 | | | | 0400.0080 | | | 0,08 | 0402.0150 | | | 0,15 |
|  | 34,0 | 8,0 | 0,30 | 0400.0100 | | | 0,10 | 0402.0200 | | | 0,20 |
| 0399.0300 | | | | 0400.0130 | | | 0,13 | 0402.0300 | | | 0,30 |
|  | 43,0 | 22,2 | 0,40 | 0400.0150 | | | 0,15 | 0402.0400 | | | 0,40 |
| 0405.0400 | | | | 0400.0200 | | | 0,20 |  | 43,0 | 22,2 | 0,10 |
|  | 43,0 | 22,2 | 0,40 | 0400.0300 | | | 0,30 | 0423.0150 | | | 0,15 |
| 0406.0400 | | | | 0400.0400 | | | 0,40 |  | 40,0 | 18,8 | 0,25 |
|  | 43,0 | 22,2 | 0,10 | 0400.0650 | | | 0,65 |  | 40,0 | 22,0 | 0,10 |
| 0403.0100 | | | | 0400.0900 | | | 0,90 | | | | |
| 0403.0150 | | | |  | 43,0 | 22,2 | 0,06 | | | | |
| 0403.0300 | | | | 0410.0080 | | | 0,08 | | | | |
|  | 43,0 | 22,2 | 0,10 | 0410.0100 | | | 0,10 | | | | |
| 0460.0250 | | | | 0410.0130 | | | 0,13 | | | | |
|  | 43,0 | 22,2 | 0,06 | 0410.0150 | | | 0,15 | | | | |
| 0410.0060 | | | | 0410.0200 | | | 0,20 | | | | |
|  | 43,0 | 22,2 | 0,08 | 0410.0300 | | | 0,30 | | | | |
| 0410.0080 | | | | 0410.0400 | | | 0,40 | | | | |
|  | 43,0 | 22,2 | 0,10 | 0410.0650 | | | 0,65 | | | | |
| 0410.0100 | | | | 0410.0900 | | | 0,90 | | | | |
|  | 43,0 | 22,2 | 0,13 | 0501.0100 | 38,0 | | 0,10 | | | | |
| 0410.0130 | | | | 0501.0150 | | | 0,15 | | | | |
|  | 43,0 | 22,2 | 0,15 | 0501.0200 | | | 0,20 | | | | |
| 0410.0150 | | | | 0501.0300 | | | 0,30 | | | | |
|  | 43,0 | 22,2 | 0,20 | 0501.0400 | | | 0,40 | | | | |
| 0410.0200 | | | | | | | | | | | |
|  | 43,0 | 22,2 | 0,30 | | | | | | | | |
| 0410.0300 | | | | | | | | | | | |
|  | 43,0 | 22,2 | 0,40 | | | | | | | | |
| 0410.0400 | | | | | | | | | | | |
|  | 43,0 | 22,2 | 0,65 | | | | | | | | |
| 0410.0650 | | | | | | | | | | | |
|  | 43,0 | 22,2 | 0,90 | | | | | | | | |
| 0410.0900 | | | | | | | | | | | |
|  | 38,0 | | 0,10 | | | | | | | | |
| 0501.0100 | | | | | | | | | | | |
|  | 38,0 | | 0,15 | | | | | | | | |
| 0501.0150 | | | | | | | | | | | |
|  | 38,0 | | 0,20 | | | | | | | | |
| 0501.0200 | | | | | | | | | | | |
|  | 38,0 | | 0,30 | | | | | | | | |
| 0501.0300 | | | | | | | | | | | |
|  | 38,0 | | 0,40 | | | | | | | | |
| 0501.0400 | | | | | | | | | | | |



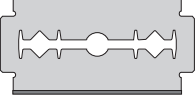
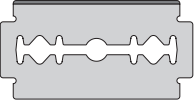
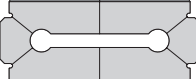
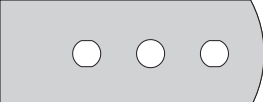
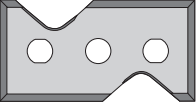

LUTZ BIÇAK AĞIZLARININ SİZE SUNDUĞU AVANTAJLAR:

- » Kenar yapmayan temiz kesim kenarları
- » Daha az kesim tozu
- » Daha yüksek kesim hızları
- » Daha seyrek bıçak ağızı değiştirme sayesinde daha yüksek verimlilik

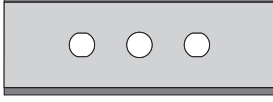
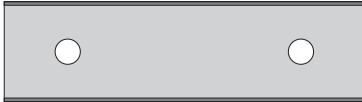
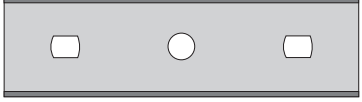
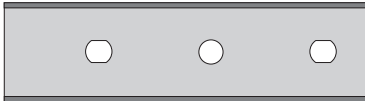
ÖZEL BIÇAK AĞIZLARI | FOLYO | SENTETİK VE CAM ELYAF | TIBBİ MALZEME | GIDA MADDELERİ | ZANAAT / DIY | OTOMOBİL | DOKUMACILIK

| Ürün No. | Boy (mm) | En (mm) | Kalınlık (mm) |
|---|----------|---------|---------------|
|  | 43,0 | 22,2 | 0,10 |
| 0420.0150 | | | 0,15 |
| 0420.0200 | | | 0,20 |
| 0420.0300 | | | 0,30 |
|  | 43,0 | 22,2 | 0,20 |
| 0436.0200 | | | |
|  | 43,5 | 19,0 | 0,10 |
| 0425.0100 | | | |
| 0428.0200 | | | 0,20 |
|  | 52,7 | 22,2 | 0,15 |
| 0520.0150 | | | |
|  | 43,0 | 22,0 | 1,00 |
| 0470.1000 | | | |

| Ürün No. | Boy (mm) | En (mm) | Kalınlık (mm) |
|--|----------|---------|---------------|
|  | 60,0 | 22,2 | 0,10 |
| 0600.0130 | | | 0,13 |
| 0600.0150 | | | 0,15 |
| 0600.0200 | | | 0,20 |
| 0600.0300 | | | 0,30 |
| 0600.0400 | | | 0,40 |
| 0500.0130 | 50,0 | | 0,13 |
| 0500.0150 | | | 0,15 |
| 0500.0300 | | | 0,30 |
|  | 80,0 | 22,2 | 0,20 |
| 0800.0200 | | | |
| 0800.0300 | | | 0,30 |
|  | 80,0 | 22,2 | 0,20 |
| 0810.0200 | | | |
| 0812.0200 | 100,0 | | |
|  | 94,0 | 22,2 | 0,30 |
| 0850.0300 | | | |

| Ürün No. | Boy (mm) | En (mm) | Kalınlık (mm) |
|---|----------|---------|---------------|
|  | 150,0 | 22,2 | 0,20 |
| 0851.0200 | | | |
|  | 118,0 | 22,2 | 0,15 |
| 0852.0150 | | | |
|  | 120,0 | 22,2 | 0,20 |
| 0853.0200 | | | |
|  | 150,0 | 22,2 | 0,20 |
| 0855.0200 | | | |
| 0856.0200 | 140,0 | | 0,20 |
| 0857.0150 | 125,0 | | 0,15 |







İYİ OLANIN DAHA DA İYİSİ – SERT MADDE KATMANLARI DAYANIKLILIĞI ARTTIRIR



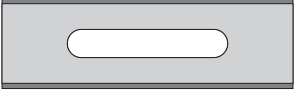
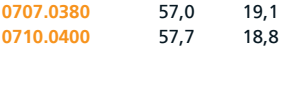



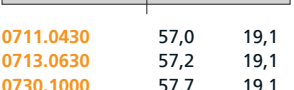
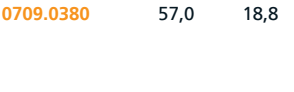

Üstün nitelikli özel bıçak ağızları sunucusu olarak, tabii ki "white film", alüminyum, yüksek dolumlu LLDPE ve PET, manyetik

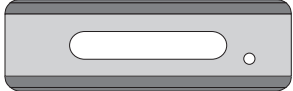
bant, OPP, BOPP ve diğer folyoların kesiminde kullanılan bıçak ağızlarının dayanıklılığını arttıran çeşitli kaplamaları (TiN,

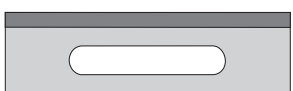
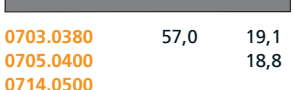
TiC, TiAlN, CrN, DLC, TiCN, PTFE vs.) sunabilecek durumdayız. Sizi bilgilendirmekten memnuniyet duyarız.

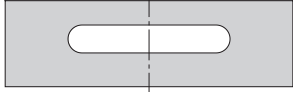
ÖZEL BIÇAK AĞIZLARI | FOLYO | SENTETİK VE CAM ELYAF | TIBBİ MALZEME | GIDA MADDELERİ | ZANAAT / DIY | OTOMOBİL | DOKUMACILIK

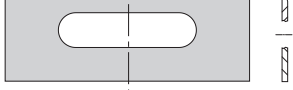
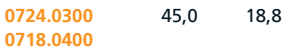
| Ürün No. | Boy (mm) | En (mm) | Kalınlık (mm) |
|--|----------|---------|---------------|
|  6030.0250 | 38,0 | 8,0 | 0,25 |
|  0707.0380 | 57,0 | 19,1 | 0,38 |
|  0710.0400 | 57,7 | 18,8 | 0,40 |
|  0697.0380 | 28,5 | 19,1 | 0,38 |
|  4307.1000 | 57,7 | 19,1 | 1,00 |
|  0711.0430 | 57,0 | 19,1 | 0,43 |
|  0713.0630 | 57,2 | 19,1 | 0,63 |
|  0730.1000 | 57,7 | 19,1 | 1,00 |
|  0709.0380 | 57,0 | 18,8 | 0,38 |

| Ürün No. | Boy (mm) | En (mm) | Kalınlık (mm) |
|--|----------|---------|---------------|
|  0700.0400 | 59,0 | 18,8 | 0,40 |
|  0698.0400 | 59,0 | 18,8 | 0,40 |
|  0703.0380 | 57,0 | 19,1 | 0,38 |
|  0705.0400 | | 18,8 | 0,40 |
|  0714.0500 | | | 0,50 |
|  0715.0900 | 59,0 | 19,1 | 0,90 |
|  0729.0630 | 57,2 | 19,1 | 0,60 |
|  0717.0630 | 57,2 | 19,1 | 0,63 |
|  0724.0300 | 45,0 | 18,8 | 0,30 |
|  0718.0400 | | | 0,40 |

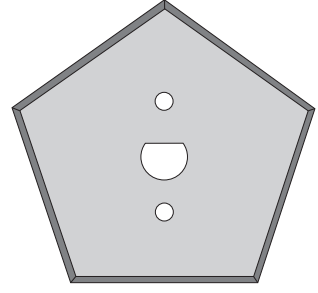
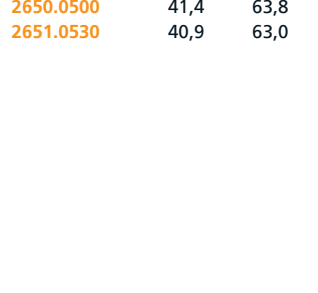
| Ürün No. | Boy (mm) | En (mm) | Kalınlık (mm) |
|--|----------|---------|---------------|
|  2650.0500 | 41,4 | 63,8 | 0,50 |
|  2651.0530 | 40,9 | 63,0 | 0,53 |

LUTZ BLADES - YUVARLAK BIÇAK AĞIZ VE BIÇAKLARI

Yuvarlak bıçak ağız ve bıçaklarımız, jilet gibi keskinlikleri, düzgünlükleri ve sertlikleri sayesinde, yıllardır piyasanın en iyilerinden sayılmaktadır.

Günbegün bunun için uğraşyoruz!
İmalatınız aksamasın diye.

ÖZEL BIÇAK AĞIZLARI | FOLYO | SENTETİK VE CAM ELYAF | TIBBİ MALZEME | GIDA MADDELERİ | ZANAAT / DIY | OTOMOBİL | DOKUMACILIK

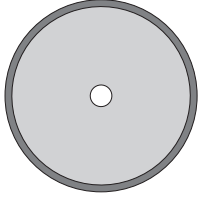
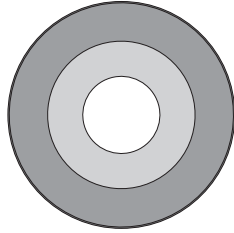
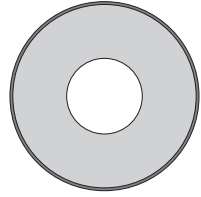
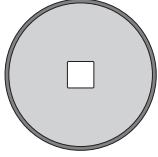
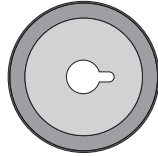
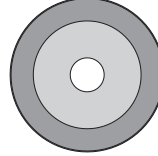
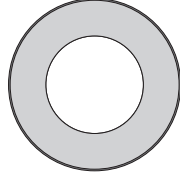
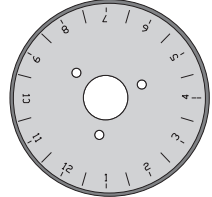
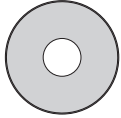
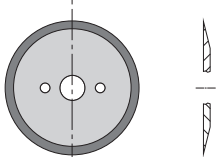
| Ürün No. | ø dış (mm) | ø iç (mm) | Kalınlık (mm) | Ürün No. | ø dış (mm) | ø iç (mm) | Kalınlık (mm) | Ürün No. | ø dış (mm) | ø iç (mm) | Kalınlık (mm) |
|---|------------|-----------|---------------|---|------------|-----------|---------------|---|------------|-----------|---------------|
|  | 254,0 | 28,6 | 3,20 |  | 100,0 | 34,0 | 1,00 |  | 50,0 | 20,0 | 0,20 |
| 0110.3200 | | | | 0125.1000 | | | | 0145.0200 | | | |
|  | 40,0 | 7,0 | 0,30 |  | 45,0 | 10,0 | 0,50 |  | 100,0 | 22,0 | 1,00 |
| 0108.0300 | | | | 0119.0500 | | | | 0115.1000 | | | |
| 0114.0300 | 26,0 | | |  | 30,0 | 17,0 | 0,10 |  | 44,0 | 10,0 | 0,30 |
|  | 30,0 | 10,0 | 0,10 | 0120.0100 | 50,0 | 25,0 | 0,15 | | | | |
| 0129.0100 | | | | 0126.0150 | 70,0 | 48,0 | 0,15 | | | | |
|  | 30,0 | 5,0 | 0,30 | 0175.0150 | | | | | | | |
| 0104.0300 | | | | | | | | | | | |



KESME MAKİNALARI İÇİN BIÇAK AĞIZLARINDA PARTNERİNİZ.

Aşağıdaki makina üreticileri için
yedek bıçak ağızları sunuyoruz:

- » Windmöller & Hölscher®
- » Reifenhäuser®
- » Starlinger®
- » Kampf®
- » Barmag®

- » Brückner®
- » SML/Lenzing®
- » Atlas®
- » Goebel®
- ...ve diğerleri

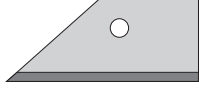
ÖZEL BIÇAK AĞIZLARI | FOLYO | SENTETİK VE CAM ELYAF | TIBBİ MALZEME | GIDA MADDELERİ | ZANAAT / DIY | OTOMOBİL | DOKUMACILIK

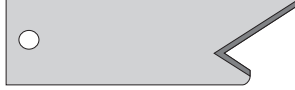
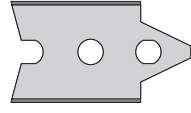
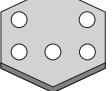
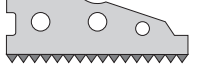
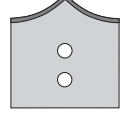
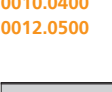
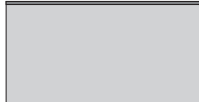
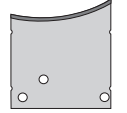
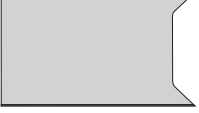
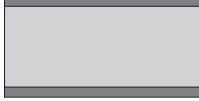









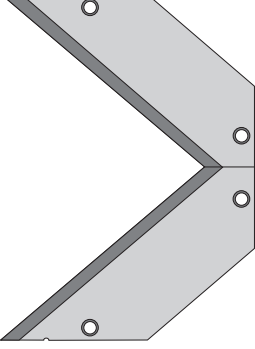
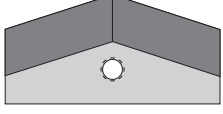

| Ürün No. | Boy (mm) | En (mm) | Kalınlık (mm) | Ürün No. | Boy (mm) | En (mm) | Kalınlık (mm) | Ürün No. | Boy (mm) | En (mm) | Kalınlık (mm) |
|--|----------|---------|---------------|--|----------|---------|---------------|--|----------|---------|---------------|
|  0021.0400 | 21,0 | 8,0 | 0,40 |  1052.0680 | 42,4 | 19,0 | 0,68 |  0840.0300 | 99,0 | 20,0 | 0,30 |
|  0023.0500 | 14,0 | 12,0 | 0,50 |  0918.0800 | 65,0 | 19,0 | 0,80 |  0220.0300 | 39,5 | 22,2 | 0,30 |
|  0010.0400 | 23,0 | 21,0 | 0,40 |  4011.0880 | 40,0 | 14,0 | 0,88 |  1240.0380 | 24,0 | 25,4 | 0,38 |
|  0012.0500 | 23,0 | 21,0 | 0,50 |  0801.0300 | 43,0 | 22,2 | 0,30 |  1350.0400 | 24,3 | 22,0 | 0,40 |
|  0441.0150 | 43,0 | 22,2 | 0,15 |  0802.0300 | 43,0 | 22,2 | 0,40 | | | | |

LUTZ BLADES, MÜŞTERİ ÇİZİMLERİNE UYGUN 500'ÜN ÜZERİNDE ÇEŞİTLİ ÖZEL BIÇAK MODELLERİ İMAL ETMEKTEDİR.

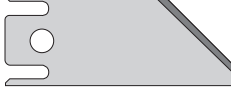
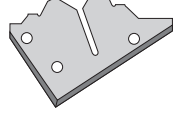
Ürün çeşitlerimiz, tırtıllı, dişli, dalgalı, eğmeli, sivri uçlu, çentikli, çoklu bıçak ağızlı, kademeli özel bıçakları veya birçok form ve şekillerin kombinasyonunu kapsamaktadır.

Hızlı prototipleme ve yüksek esnekli üretim teknolojileri sayesinde küçük (ve mini) serilerinizi birkaç günde üretiyoruz!

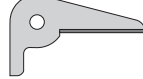

ÖZEL BIÇAK AĞIZLARI | FOLYO | SENTETİK VE CAM ELYAF | TIBBİ MALZEME | GIDA MADDELERİ | ZANAAT / DIY | OTOMOBİL | DOKUMACILIK

| Ürün No. | Boy (mm) | En (mm) | Kalınlık (mm) | Ürün No. | Boy (mm) | En (mm) | Kalınlık (mm) | Ürün No. | Boy (mm) | En (mm) | Kalınlık (mm) |
|--|----------|---------|---------------|---|----------|---------|---------------|---|----------|---------|---------------|
|  | 92,0 | 67,9 | 0,50 |  | 50,0 | 25,0 | 2,0 |  | 21,5 | 11,5 | 0,69 |
|  | 29,0 | 5,0 | 0,40 |  | 12,0 | 4,1 | 0,40 |  | 41,0 | 5,6 | 0,50 |
|  | 90,0 | 14,0 | 2,50 |  | 50,0 | 20,0 | 0,40 |  | 32,0 | 32,0 | 0,69 |
|  | 18,8 | 4,8 | 0,50 |  | 7,0 | 7,0 | 0,68 |  | 23,0 | 15,6 | 0,65 |
| | | | |  | 10,3 | 12,0 | 1,20 |  | 30,0 | 18,5 | 1,25 |
|  | 413,0 | 40,0 | 1,00 | | | | | | | | |

LUTZ FOLYO BIÇAK AĞIZLARININ ÖZELLİKLERİ:

- » En iyi ham maddeler
- » En uygun sertlik
- » En dar toleranslara uyum
- » Seçkin üstün nitelikli kaplamalar

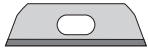
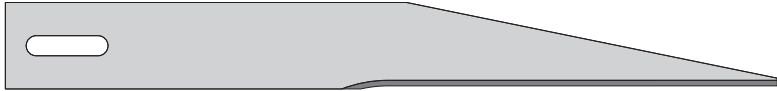
ÖZEL BIÇAK AĞIZLARI | FOLYO | SENTETİK VE CAM ELYAF | TIBBİ MALZEME | GIDA MADDELERİ | ZANAAT / DIY | OTOMOBİL | DOKUMACILIK

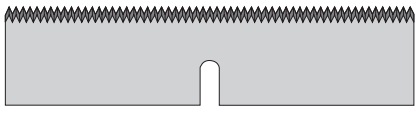
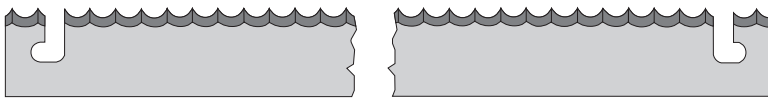
| Ürün No. | Boy (mm) | En (mm) | Kalınlık (mm) | Ürün No. | Boy (mm) | En (mm) | Kalınlık (mm) | Ürün No. | Boy (mm) | En (mm) | Kalınlık (mm) |
|--|----------|---------|---------------|---|----------|---------|---------------|---|----------|---------|---------------|
|  | 31,0 | 9,0 | 0,60 |  | 33,3 | 7,8 | 0,30 |  | 14,0 | 12,9 | 0,40 |
| 2530.0600 | | | | 2525.0300 | | | | 2194.0400 | | | |
|  | 250,0 | 28,0 | 1,00 | | | | | | | | |
| 9540.1000 | | | | | | | | | | | |
|  | 112,0 | 19,0 | 0,38 |  | 60,0 | 64,0 | 1,20 | | | | |
| 4200.0380 | | | | 9580.1200 | | | | | | | |
| 4200.0400 | | | 0,40 | | | | | | | | |
|  | 40,5 | 8,2 | 0,40 | | | | | | | | |
| 2222.0400 | | | | | | | | | | | |
|  | 108,0 | 25,4 | 0,51 | | | | | | | | |
| 8115.0510 | | | | | | | | | | | |
|  | 499,0 | 20,0 | 1,00 | | | | | | | | |
| 3053.1000 | | | | | | | | | | | |

BIÇAK KENARI ŞEKİLLERİ

| | | 1-biçak kenarlı | 2-biçak kenarlı | Konkav | Konveks |
|-----------|--|-----------------|-----------------|--------|---------|
| 1-tarafli | | a | g | m | t |
| | | b | h | n | u |
| | | c | i | o | v |
| 2-tarafli | | d | j | p | w |
| | | e | k | r | x |
| | | f | l | s | y |

KAPLAMALAR

LUTZ kaplama programının kapsadığı çeşitler

TiN

Nispeten yüksek sürtünme kat sayısı (referans maddesi çeliğe karşı yaklaşık 0,4 - 0,7) aşınmaya karşı yüksek dirençli standart sert madde, genelde altın renginde, güvenli kullanım alanı yaklaşık 300 °C kadar.

TiC

Belirgin şekilde daha düşük sürtünme kat sayısı (referans maddesi çeliğe karşı yaklaşık 0,3 - 0,5) aşınmaya karşı TiN'den daha düşük dirence sahip, genelde antrasit renkli.

TiCN

Aşınmaya yüksek dirençli TiN ile düşük sürtünme kat sayılı TiC arasında sağlayan tabaka maddesi, C ve N'in oranlarına göre TiN ve TiC arasında değişken pozisyonda, genelde antrasit renkli.

TiAlN

Benzer sürtünme kat sayısı paslanmaya karşı TiN'den daha yüksek dirence sahip, genelde antrasit renkli. ZrN/Aşınma direnci TiN'ye benzer ama yapısı (morfoloji) TiN'den daha sıkı ve bununla yüklenildiğinde oyulmaya

karşı daha yüksek dirençli, genelde çelik renkli.

ZrN

Aşınma direnci TiN'ye benzer ama yapısı (morfoloji) TiN'den daha sıkı ve bununla yüklenildiğinde oyulmaya karşı daha yüksek dirençli, genelde çelik renkli.

CrN

Aşınmaya karşı TiN'den daha düşük dirence sahip. CrN'nin avantajı: TiN'den daha düşük iç gerilim. Bu yüzden yüksek eğilme yüklü uygulamalarda kullanılması kısmen anlamlıdır.

DLC

Düşük sürtünme kat sayısı (referans madde çeliğe karşı yaklaşık 0,1) aşınmaya karşı yüksek dirence sahip; vurucu yüklere ve yüksek sıcaklıklara (yapıya göre 100 - 300 °C) karşı nazik.

Teflon® PTFE

Yapışmaz kaplama Teflon® PTFE; çok düşük yüzey gerilimi sayesinde bıçak ağzına hiç bir yabancı madde

HAM MADDE SEÇENEKLERİ

Biçak ağızlarımızı 0,06 – 3,0 mm kalınlığında ve 40 - 85 HRC nihai sertlik derecelerinde işlemekteyiz.

Ham madde programımızın kapsamı:

- » Karbon çelikler
- » Pasa dayanıklı ve paslanmaz çelikler
- » Yüksek performanslı hızlı çelikler (HSS)
- » Alet çelikleri
- » Karbitler
- » Keramikler

Ham madde seçimi kriterleri:

- » Bulunurluk
- » Kesim işlemi çevresi
- » Pasa dayanıklılık
- » Dayanıklılık
- » Uygun maliyetlilik
- » Biçak kenarı özellikleri
- » Darbe dayanıklılığı

yapışmaz, asit ve bazlara dayanıklı; sürtünme direnci belirgin şekilde düşük; çok düşük statik sürtünme ani çekmeler olmadan kesim yapmayı sağlar, (bu yüzden tıbbi alan için çok uygundur); aşınmaya karşı düşük direnç; Natrium teması ve 250°C üzerindeki sıcaklıklar için uygun değildir.

Renkli vernik

Tamamen kaplayacak şekilde uygulanır, farklı melzeme kalınlıklarını düzenlemeye ve pastan korumaya yarar.

Çivitleme / Karartma

Tamamen kaplayacak şekilde uygulanır, paslanmaya ve incelmeye karşı hafif koruma sunar, ayırtetmeye de yarar.