

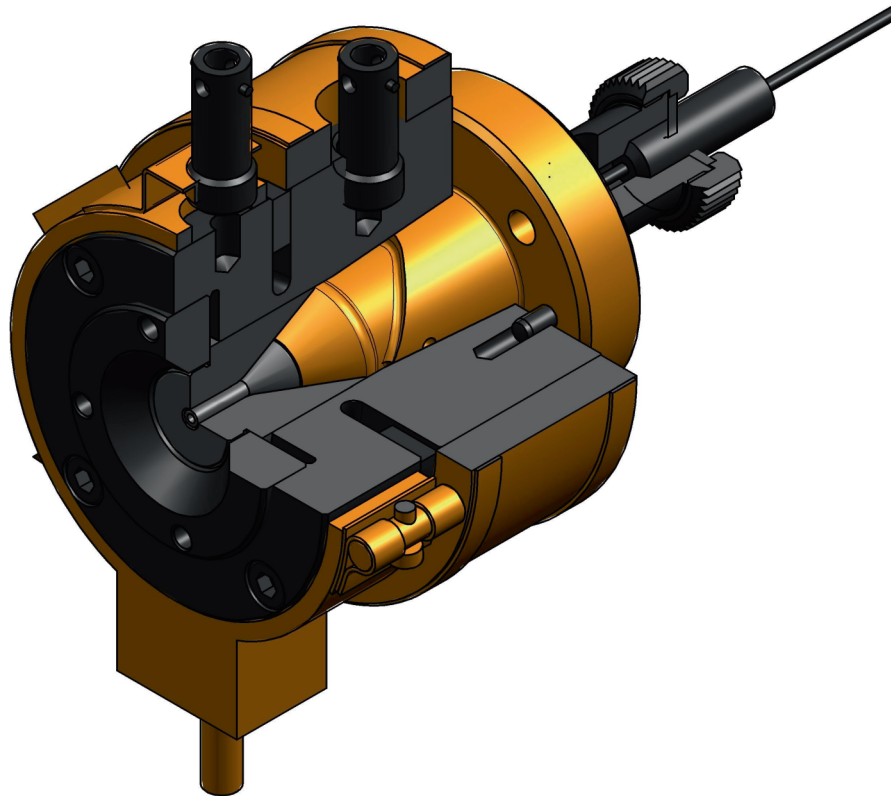

Crosshead UXHFMCC-F 3/20



Crosshead UXHFMCC-F 3/20

art.no. 2.0000.1859

- . compact
- . simple design
- . flexible
- . easy to use
- . easy to maintain

The F 3/20 series crossheads were developed for small stranded and solid conductors. Its UNALLOY casing is designed for the extrusion of fluoro-polymer products. The fine-centering system, the accurate manufacturing and the well-proven design allows concentricity levels of nearly 100% - a guarantee for your high-end products.

Field of application

- . data cables
- . microelectronics
- . medical applications
- . automotive wires



Line direction

- . r/l
- . l/r

Toolings

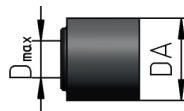

- . $D_A = 35\text{mm}$ (1.378")
- . $D_{\text{max}} = 20\text{mm}$ (.787")



- . $d_A = 17\text{mm}$ (.669")
- . $d_{\text{max}} = 3\text{mm}$ (.118")

Weight (approx. net)

- . 10,5kg (23,1lbs)

Centering

- . fine-centering

2.0000.4531-e-1



UNITEK

We Make Leading Products Happen.

Crosshead UXHFMCC-F 3/20

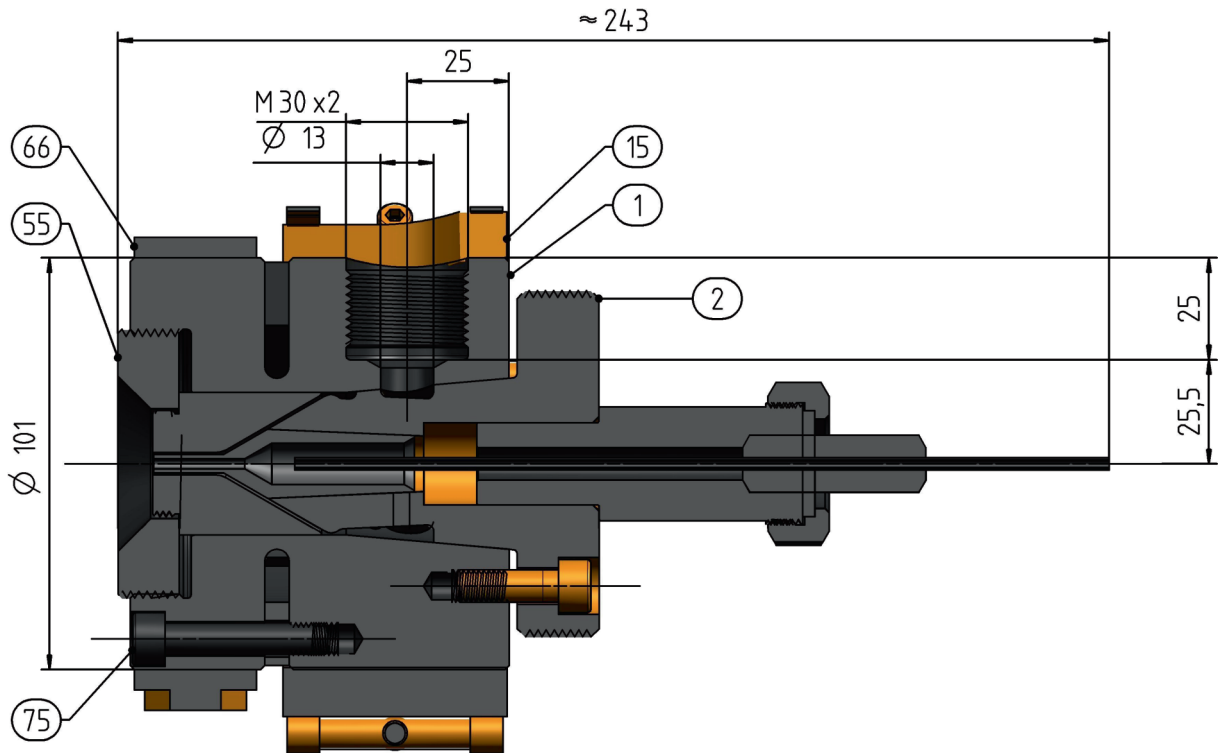

Main parts

1	basehead casing		75	centering screws
2	cartridge			
15	casing heaterband	1000W		
55	die nut			
65	fronthead heaterband	900W		

Scope of delivery

- . tools for assembly & cleaning
- . thermocouples
- . support rod
- . vacuum adapter
- . user manual & parts list

Options

- . extrusion tools (wire guides & dies)
- . custom made cartridges
- . adapters
- . cartridge heater, 200W

2.0000.4531-e-1

Unitek Maschinenbau- und Handels GmbH | Wien / Vienna | Österreich / Austria

tel: +43 - 1 - 3325510 | fax: +43 - 1 - 3325515 | email: office@unitek.at | web: www.unitek.at

DVR-Nr: 0178.349 | UID-Nr: ATU 150 76 101 | Registered at the commercial court Vienna CN: 102796x | Registered office: Vienna