



25-50 Kg
Yüksek Hassasiyetli
Torbalama Makineleri

High Precision Bagging and Filling Machines 25-50 kg

MAKE A DIFFERENCE

with your high quality and low cost bagging machine.



Çift Tartım, Tek İstasyon Toralama Makinesi

Double Weighing, Single Station Bagging Machine

KLAPELİ
Flap

Farklı hububat çeşitlerini verimli bir şekilde torbaya doldurmak için ideal olan BM01 25-50 kg arasındaki değişken tartım kapasitesi ve $\pm 50-150$ gr hassasiyeti ile öne çıkıyor. HMI dokunmatik ekran kontrol ünitesi ve BSC65 tartım indikatörü sayesinde kalibrasyon ve doğru ağırlık belirleme işlemlerinde mükemmel performans sunar.

Ideal for efficiently bagging different types of cereals, the BM01 stands out with its variable weighing capacity between 25-50 kg and accuracy of $\pm 50-150$ g. Thanks to its HMI touch screen control unit and BSC65 weighing indicator, it offers excellent performance in calibration and accurate weight determination.

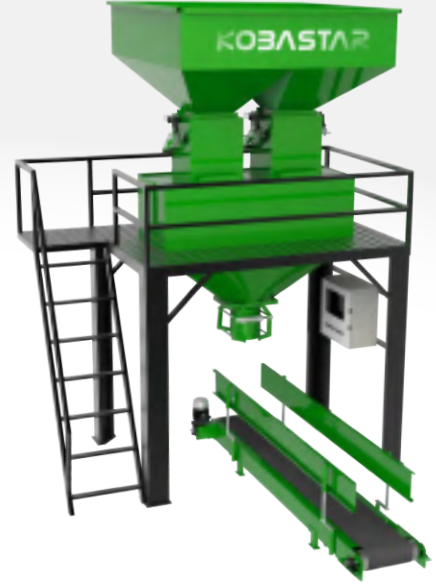

Teknik Özellikler | Technical Features

DETAY	BM-01	BM-02	DETAILS	BM-01	BM-02
Paketlenecek Ürün Türü	Hububat Çeşitleri	Pelet, Kömür vb.	Type of Packaged Product	Types of Cereals	Pellets, Coal etc.
Maksimum Tartım Ağırlığı	Değişken	Değişken	Max. Weighing Capacity	Variable	Variable
Tartım Aralığı Seçenekleri	25 - 50 Kg	25 - 50 Kg	Weighing Range Options	25 - 50 Kg	25 - 50 Kg
Tartım Doğruluğu	$\pm 50 - 150$ gr	$\pm 50 - 150$ gr	Weighing Accuracy	$\pm 50 - 150$ gr	$\pm 50 - 150$ gr
Üst Bunker Kapasitesi	3000 Litre (Değişken)	3000 Litre (Değişken)	Upper Bunker Capacity	3000 Lt. (Variable)	3000 Lt. (Variable)
Tartım Sistemi	BSC65 - HMI Display	BSC65 - HMI Display	Weighing System	BSC65 - HMI Display	BSC65 - HMI Display
Çıkış Kapasitesi 25-50 Kg	19 - 22 / 17 - 19 Ton/Saat	19 - 22 / 17 - 19 Ton/Saat	Output Capacity 25-50 Kg	19 - 22 / 17 - 19 Tons per Hour	19 - 22 / 17-19 Tons per Hour
Tartım Üniteleri 25-50 Kg	750 - 400 Paket / Saat	750 - 400 Paket / Saat	Weighing Units 25-50 Kg	750 - 400 Bags per Hour	750 - 400 Bags per Hour
Sistem Basıncı	(300lt. Kompresör) 8-10 Bar	(300lt. Kompresör) 8-10 Bar	System Pressure	(300lt. Compressor) 8-10 Bar	(300lt. Compressor) 8-10 Bar
Güç Kaynağı (VAC)	($\pm 5\%$ - 10%) 400VAC / 50-60Hz.	($\pm 5\%$ - 10%) 400VAC / 50-60Hz.	Power Supply (VAC)	($\pm 5\%$ - 10%) 400VAC / 50-60Hz	($\pm 5\%$ - 10%) 400VAC / 50-60Hz
Ağırlık	2.300 Kg	2.300 Kg	Weight	2,300 Kg	2,300 Kg

Çift Tartım, Tek İstasyon Toralama Makinesi

Double Weighing, Single Station Bagging Machine

KONVEYÖR
BANT
Conveyor belt

Pelet, Kömür, Pomza Taşı vb. çeşitlerini verimli bir şekilde torbaya doldurmak için ideal olan BM02, 25-50 kg arasındaki değişken tartım kapasitesi ve $\pm 50-150$ gr hassasiyeti ile öne çıkıyor. Kullanıcı dostu HMI dokunmatik ekran kontrol ünitesi ve BSC65 tartım indikatörü sayesinde kalibrasyon ve doğru ağırlık belirleme işlemlerinde mükemmel performans sunar.

BM02, which is ideal for efficiently filling pellets, coal, pumice stone etc. into bags, stands out with its variable weighing capacity between 25-50 kg and accuracy of $\pm 50-150$ g. Thanks to its user-friendly HMI touch screen control unit and BSC65 weighing indicator, it offers excellent performance in calibration and accurate weight determination.



Tek Tartım, Tek İstasyon Torbalama Makinesi

One Weighing, One Station Bagging Machine

KLAPELİ
Flap

Farklı hububat çeşitlerini verimli bir şekilde torbaya doldurmak için ideal olan BM03 25-50 kg arasındaki değişken tartım kapasitesi ve $\pm 50-150$ gr hassasiyeti ile öne çıkıyor. HMI dokunmatik ekran kontrol ünitesi ve BSC65 tartım indikatörü sayesinde kalibrasyon ve doğru ağırlık belirleme işlemlerinde mükemmel performans sunar.

Ideal for efficiently bagging different types of cereals, the BM03 stands out with its variable weighing capacity between 25-50 kg and accuracy of $\pm 50-150$ g. Thanks to its HMI touch screen control unit and BSC65 weighing indicator, it offers excellent performance in calibration and accurate weight determination.

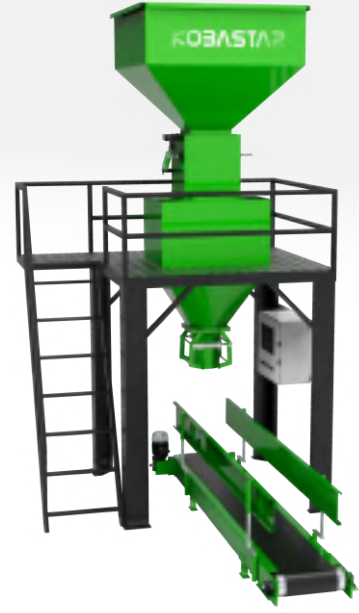

Teknik Özellikler | Technical Features

DETAY	BM-03	BM-04	DETAILS	BM-03	BM-04
Paketlenecek Ürün Türü	Hububat Çeşitleri	Pelet, Kömür vb.	Type of Packaged Product	Types of Cereals	Pellets, Coal etc.
Maksimum Tartım Ağırlığı	Değişken	Değişken	Max. Weighing Capacity	Variable	Variable
Tartım Aralığı Seçenekleri	25 - 50 Kg	25 - 50 Kg	Weighing Range Options	25 - 50 Kg	25 - 50 Kg
Tartım Doğruluğu	$\pm 50 - 150$ gr	$\pm 50 - 150$ gr	Weighing Accuracy	$\pm 50 - 150$ gr	$\pm 50 - 150$ gr
Üst Bunker Kapasitesi	1800 Litre (Değişken)	1800 Litre (Değişken)	Upper Bunker Capacity	3000 Lt. (Variable)	1800 Lt. (Variable)
Tartım Sistemi	BSC65 - HMI Display	BSC65 - HMI Display	Weighing System	BSC65 - HMI Display	BSC65 - HMI Display
Çıkış Kapasitesi 25-50 Kg	9 - 12 / 9 - 11 Ton/Saat	8 - 10 / 9 - 10 Ton/Saat	Output Capacity 25-50 Kg	9 - 12 / 9 - 11 Tons per Hour	8 - 10 / 9 - 10 Tons per Hour
Tartım Üniteleri 25-50 Kg	440 - 200 Paket / Saat	400 - 250 Paket / Saat	Weighing Units 25-50 Kg	440 - 200 Bags per Hour	400 - 250 Bags per Hour
Sistem Basıncı	(300lt. Kompresör) 8-10 Bar	(300lt. Kompresör) 8-10 Bar	System Pressure	(300lt. Compressor) 8-10 Bar	(300lt. Compressor) 8-10 Bar
Güç Kaynağı (VAC)	($\pm 5-10\%$) 400VAC / 50-60Hz.	($\pm 5-10\%$) 400VAC / 50-60Hz.	Power Supply (VAC)	($\pm 5-10\%$) 400VAC / 50-60Hz	($\pm 5-10\%$) 400VAC / 50-60Hz
Ağırlık	1.400 Kg	1.700 Kg	Weight	1,400 Kg	1,700 Kg

Tek Tartım, Tek İstasyon Torbalama Makinesi

One Weighing, One Station Bagging Machine

KONVEYÖR
BANT
Conveyor belt

Pelet, Kömür, Pomza Taşı vb. çeşitlerini verimli bir şekilde torbaya doldurmak için ideal olan BMO4, 25-50 kg arasındaki değişken tartım kapasitesi ve $\pm 50-150$ gr hassasiyeti ile öne çıkıyor. Kullanıcı dostu HMI dokunmatik ekran kontrol ünitesi ve BSC65 tartım indikatörü sayesinde kalibrasyon ve doğru ağırlık belirleme işlemlerinde mükemmel performans sunar.

BMO4, which is ideal for efficiently filling pellets, coal, pumice stone etc. into bags, stands out with its variable weighing capacity between 25-50 kg and accuracy of $\pm 50-150$ g. Thanks to its user-friendly HMI touch screen control unit and BSC65 weighing indicator, it offers excellent performance in calibration and accurate weight determination.



Tek Tartım, Tek İstasyon Torbalama Makinesi

One Weighing, One Station Bagging Machine

KLAPELİ
Flap

Farklı hububat çeşitlerini verimli bir şekilde torbaya doldurmak için ideal olan BM05 Eko 25-50 kg arasındaki değişken tartım kapasitesi ve $\pm 50-200$ gr hassasiyeti ile öne çıkıyor. HMI dokunmatik ekran kontrol ünitesi ve BSC65 tartım indikatörü sayesinde kalibrasyon ve doğru ağırlık belirleme işlemlerinde mükemmel performans sunar.

BM05 Eko, which is ideal for efficiently bagging different types of cereals, stands out with its variable weighing capacity between 25-50 kg and accuracy of $\pm 50-200$ g. Thanks to its HMI touch screen control unit and BSC65 weighing indicator, it offers excellent performance in calibration and accurate weight determination.

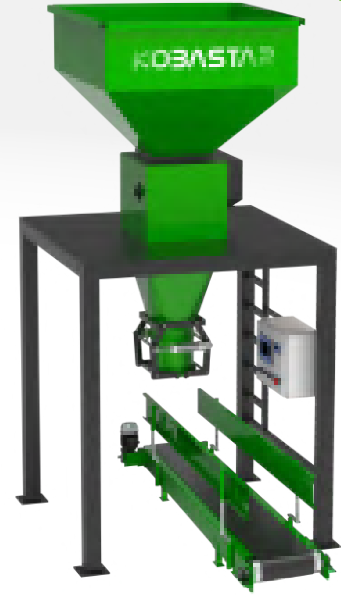

Teknik Özellikler | Technical Features

DETAY	BM-05 EKO	BM-06 / HELEZONLU	DETAILS	BM-05 ECO	BM-06 / HELEZONED
Paketlenecek Ürün Türü	Hub. Çeşitleri - P. Gübre	Toz Ürünler	Type of Packaged Product	Cereal Varieties - Poly. Fertilizer	Powder Types
Maksimum Tartım Ağırlığı	Değişken	Değişken	Max. Weighing Capacity	Variable	Variable
Tartım Aralığı Seçenekleri	25 - 50 Kg	5 - 10 - 15 - 20 - 25 - 50 Kg	Weighing Range Options	25 - 50 Kg	5 - 10 - 15 - 20 - 25 - 50 Kg
Tartım Doğruluğu	$\pm 50 - 200$ gr	$\pm 50 - 100$ gr	Weighing Accuracy	$\pm 50 - 200$ gr	$\pm 50 - 100$ gr
Üst Bunker Kapasitesi	500 Litre (Değişken)	200 Litre (Değişken)	Upper Bunker Capacity	500 Lt. (Variable)	200 Lt. (Variable)
Tartım Sistemi	BSC65 - HMI Display	BSC65 - HMI Display	Weighing System	BSC65 - HMI Display	BSC65 - HMI Display
Çıkış Kapasitesi 25-50 Kg	6 - 7 / 6 - 7 Ton/Saat	6 - 7 / 6 - 7 Ton/Saat	Output Capacity 25-50 Kg	6 - 7 / 6 - 7 Tons per Hour	6 - 7 / 6 - 7 Tons per Hour
Tartım Üniteleri 25-50 Kg	270 - 270 Paket / Saat	270 - 270 Paket / Saat	Weighing Units 25-50 Kg	270 - 270 Bags per Hour	270 - 270 Bags per Hour
Sistem Basıncı	(300lt. Kompresör) 8-10 Bar	(300lt. Kompresör) 8-10 Bar	System Pressure	(300lt. Compressor) 8-10 Bar	(300lt. Compressor) 8-10 Bar
Güç Kaynağı (VAC)	($\pm 5-10\%$) 400VAC / 50-60Hz.	($\pm 5-10\%$) 400VAC / 50-60Hz.	Power Supply (VAC)	($\pm 5-10\%$) 400VAC / 50-60Hz	($\pm 5-10\%$) 400VAC / 50-60Hz
Ağırlık	750 Kg	500 Kg	Weight	750 Kg	500 Kg

Helezonlu Torbalama Makinesi

One Weighing, One Station Bagging Machine

HELEZON
Helix Spiral

Orta ve yüksek yoğunluktaki granül toz, ince toz ve öğütülmüş ürünleri helezon sayesinde verimli bir şekilde torbaya doldurmak için ideal olan BM06, 5-10-15-20-25-50 kg arasındaki değişken tartım kapasitesi ve $\pm 50-100$ gr hassasiyeti ile öne çıkıyor. Paslanmaz seçenekleri de bulunan BM 06 Model, HMI dokunmatik ekran kontrol ünitesi ve BSC65 tartım indikatörü sayesinde kalibrasyon ve doğru ağırlık belirleme işlemlerinde mükemmel performans sunar.

BM06, which is ideal for filling medium and high density granular powder, fine powder and ground products into the bag efficiently thanks to the auger, stands out with its variable weighing capacity between 5-10-15-20-25-50 kg and $\pm 50-100$ g precision. BM 06 Model, which also has stainless steel options, offers excellent performance in calibration and accurate weight determination processes thanks to its HMI touch screen control unit and BSC65 weighing indicator.



KOBASTAR® Torbalama Makineleri ile işletmenizin paketleme ihtiyaçlarını düşünmeyin. BM Serisi modelleri ile 25 kg'dan 50 kg'a kadar farklı ölçülerde paketleme yapabilirsiniz. Dokunmatik kontrol paneli sayesinde tüm fonksiyonları tek ekrandan görüntüleyebilir, ürünün ağırlığı ve adedi ile ilgili bilgilere ulaşabilir ve müdahale edebilirsiniz. Saatte 10-15 ton arası paketleme kapasitesine sahip BM Serisi Torbalama Makineleri ile işler her zamankinden daha hızlı. BM Serisi Torbalama Makineleri ile Pomza taşı, toz çeşitleri, kaba yem, pelet yem, arpa, buğday, gübre, mısır, pirinç, yulaf ve endüstriyel atıkların paketlenmesinde kullanabilirsiniz.

Don't worry about your business's packaging needs with KOBASTAR® Bagging Machines. With our BM Series models, you can package different scales from 25 kg to 50 kg. Through the touchscreen control panel, you can view all functions from a single screen, access information about the weight and quantity of the product, and intervene as needed. With a packaging capacity ranging from 10 to 15 tons per hour, the BM Series Bagging Machines make operations faster than ever. You can use BM Series Bagging Machines for packaging Pumice stone, various powders, coarse feed, pellet feed, barley, wheat, fertilizer, corn, rice, oats, and industrial wastes.



25-50 Kg Yüksek Hassasiyetli Torbalama Makineleri High Precision Bagging and Filling Machines 25-50 kg



■ KLAPE ÖZELLİĞİ İLE HASSAS PAKETLEME

WITH VALVE FEATURE
DELICATE PACKAGING

Bu mekanizma, torbalama işlemi sırasında malzemenin daha iyi paketlenmesini ve üretim verimliliğini artırır.

This mechanism improves the packaging of the material during bagging process and increases production efficiency.



■ ÇİFT BUNKER VE KAPASİTE ARTIRIMI

DOUBLE BUNKER AND
CAPACITY INCREASE

Birbirinden bağımsız çalışabilen çift bunker seçeneği ile iki ayrı tartımı tek bir gövdede sırasıyla performanslı bir şekilde paketlenmesi sağlanmıştır.

With the double bunker option, which can operate independently of each other, two separate weighings are packaged in a single body respectively in a performance manner.



■ HMI KONTROL HMI CONTROL

HMI arayüzü üzerinden makine tartım kalibrasyonu ayarlayabilir, üretim süreçlerini izleyebilir, hata durumlarını tespit edebilir ve sistem performansını kontrol edebilirler.

Operators can calibrate machine weighing, monitor production processes, detect errors, and control system performance through the HMI interface.

kobastar.com



Merkez Ofis | Head Office

Org. San. Böl. Fevzi Çakmak Mah.
Ayyıldız Cad. No : 103/B
Karatay/Konya/Türkiye

Fabrika | Factory

Org. San. Böl. Fevzi Çakmak Mah.
Milenyum Cad. No : 11/B
Karatay/Konya/Türkiye

Domestic Offices

İstanbul | Ankara | İzmir

İletişim | Contact us

+90 332 249 38 15
bilgi@kobastar.com

Contact Sales

+90 538 031 64 35 EN
sales1@kobastar.com

+90 533 031 28 25 RU
sales2@kobastar.com

+90 530 382 64 94 FR
export@kobastar.com

+90 553 379 99 77 AR
sales@kobastar.com

