



- Quality Is Our Nature
- In Search of Excellence
- LEADWELL Leads the Industry in Taiwan, in the World

**LEADWELL**  
LEADWELL CNC MACHINES MFG., CORP.



**LEADWELL CNC MACHINES MFG., CORP.**



NO.23, Gong 33th Road, Taichung Industrial Park  
Taichung 407, Taiwan  
TEL: 886-4-23591880  
FAX: 886-4-23592555  
E-mail: sales@leadwell.com.tw

**www.leadwell.com.tw**

※ All performance are based on 220V/3PH/60HZ. Specification are subject to change without notice.

**T/LTC Series**

**CNC TURNING CENTER**

**T-5i/iM  
T-6i/iL/iM/iLM  
LTC-200/L/M/LM/MY/LMY**



## The Ultimate in Value and High Performance



- The Ultimate Combination of Power, Versatility & Value in a Linear Way Lathe

TRAVEL	T-5i(Gang type)	T-5i(Turret)	T-5iM	T-6i	T-6iL	T-6iM	T-6iLM
X axis	230mm	150+15mm	120+10mm	150+15mm	150+15mm	150+15mm	150+15mm
Z axis	230mm	186mm	190mm	338mm	538mm	338mm	538mm
Chuck Size	6	6	6	8	8	8	8
Bar Capacity	45mm	45mm	45mm	45mm	45mm	45mm	45mm



- Rear Side Chip Removal  
Machine width 1530mm

TRAVEL	LTC-200	LTC-200L
X axis	150+20mm	150+20mm
Z axis	338mm	538mm
Chuck Size	8	8
Bar Capacity	52mm	52mm

TRAVEL	LTC-200M	LTC-200LM	LTC-200MY	LTC-200LMY
X axis	150+15mm	150+15mm	150+40mm	150+40mm
Z axis	338mm	538mm	338mm	538mm
Chuck Size	8	8	8	8
Bar Capacity	52mm	52mm	52mm	52mm

### MACHINE ENCLOSURE

- T/LTC series machines are fully enclosed with splash guards and way covers.
- CE approved guarding is also available as an option.





# STRUCTURE

## LEADWELL APPLIES ADVANCED CONCEPTS TO CREATE PERFECTION IN STRUCTURAL DESIGN.

- LEADWELL uses only top quality well-ribbed castings.
- Finite Element Analysis (FEA) is used on each new casting to determine the size and location of all internal ribs ensuring high torsional stiffness and minimum vibration.
- The cast iron base, saddle, headstock, slide and tailstock are ruggedly constructed for superior stability and machining accuracy.

## LIVE TOOL TURRET

- Each tool can become a rotating tool for both milling and drilling operations.
- Tools can be either radially or axially oriented.

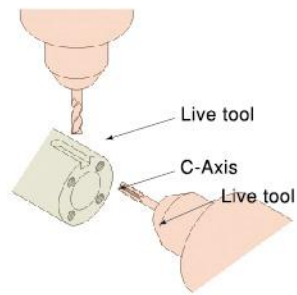

### Power Turret Cutting Capacity:

Tool	12 live tools
Drill	10mm
End Mill	12mm
Tapping	M10xP1.5

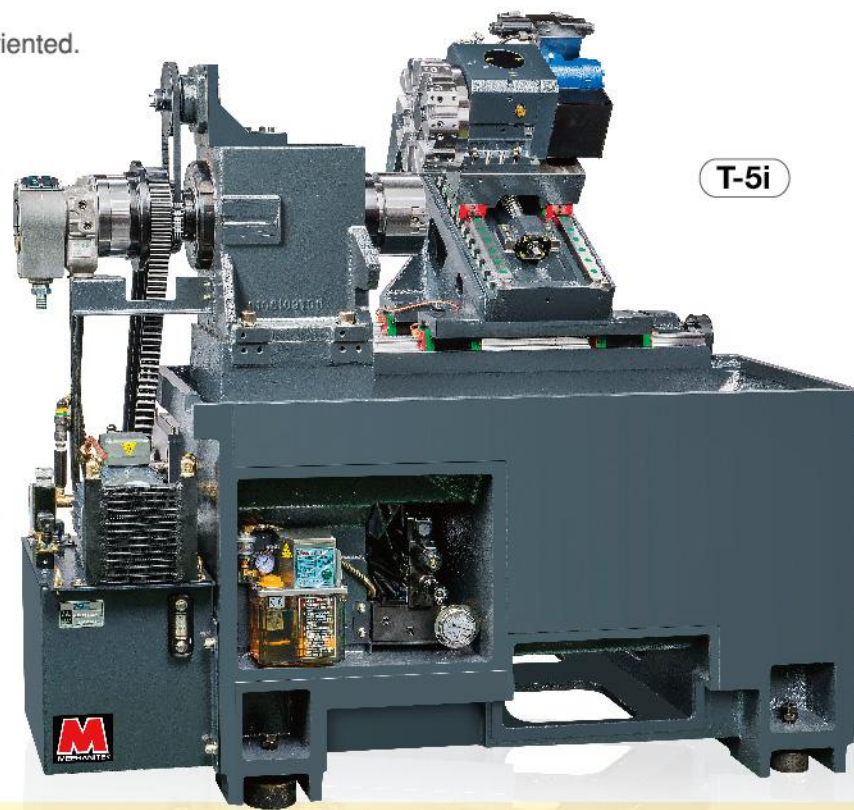

## MORE POWERFUL

- Powerful main spindle 7.4 HP~14.7 HP
- Rigid 30 deg. Slant bed cast iron base

## INCREASED CAPACITY

- 6~8 inch chuck standard
- $\Phi 45\text{mm} \sim \Phi 52\text{mm}$  bar capacity standard

## FASTER/ MORE PRODUCTIVE

- Fast rapid rates 20 ~30m/min
- Spindle speed 4000~6000 rpm
- C axis and VDI 25 live tooling version available
- Y axis travel  $\pm 50\text{mm}$

## ERGONOMIC CONSIDERATIONS

- Easy to use membrane touch-pad control station
- Easy moving operator door
- Parts catcher available
- No chip or coolant leaks

# STRUCTURE

## EXTRA WIDE SPAN FOR INCREASED STABILITY

- The T/LTC series utilizes oversized box ways for high horse power machining. The extremely rigid body base frame with box ways provides outstanding stability for precision turning.

## HEADSTOCK

- The headstock is a thermally symmetric design with heat dissipating fins for effectively increasing heat dissipation effect. This design prevents thermal distortion during long machining cycles.

## 30° MASSIVE SLANT BED

### Easy Chip Disposal

- The 30° degree slant bed design allows chips to fall directly into the chip tank, avoiding accumulation inside the machine.
- The chip tank employs large wheels, making it easy to move for chip removal and cleaning.
- Chain-type chip conveyor (optional) available on all models.

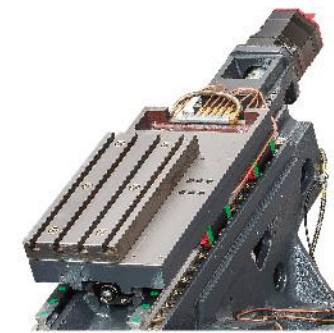

Gain Type Turret  
6 Stations



LTC-200MY

## LTC-200 SERIES

- Heavy Duty Cutting and Box Way Design
- Big Capacity Small Floor Space
- Machine Width 1530mm
- Turning Diameter 300mm
- Turning Length 300mm/500mm
- 8-12 Station Turret
- Back Side Chip Remove
- Bar Feeder, Parts Catcher, tool setter Available



# AUTOMATION SYSTEM AVAILABLE

## One piece design



## Gantry Robot (Optional)

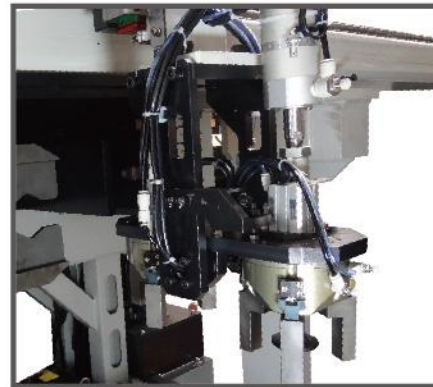

## IN/OUT Stoker (optional)



From transmissions to components which have different shape, size and capacity are capable to be manufactured by Gantry Robot System.

### ► Gantry Robot

Components		Unit	LEADWELL	
Full Body	Workpiece Diameters	Max. Diameter	mm 120	
		Max. Length	mm 100	
		Max. Payload	kg 3.0	
Robot Arm Body	Shoulder (Travel Axis: Z)	Travel	mm 1300	
		Feed Rate	m/min 160	
	Arm (Up/down axis : Y)	Travel	mm 600	
		Feed Rate	m/min 100	
	Wrist Turning Diameter	Servo	-	Pneumatic Cylinder
		Angle	degree	90
		Wrist Style	-	L Shape Wrist
Claws	Servo	-	Pneumatic Cylinder	
	Claw Travel	mm	8	

# FEA REPORT(Finite Element Analysis)

## Optimum

- Section areas
- Moments of inertia
- Torsional constant
- Plate thickness
- Bending stiffness
- Transverse shear
- Vibration reduce

## With FEA you can

1. Predict and improve product performance and reliability.
2. Reduce physical prototyping and testing .
3. Evaluate different designs and materials .
4. Optimize designs.

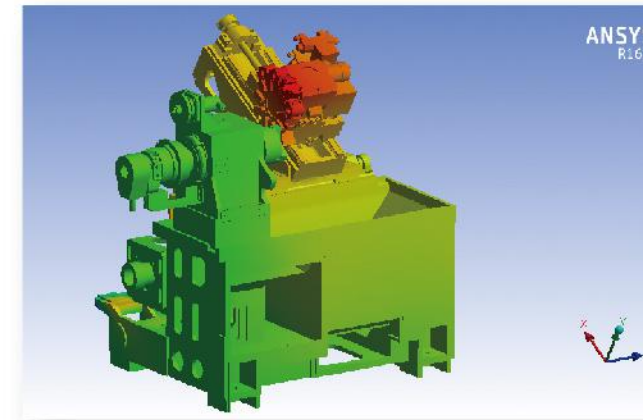

T-5i

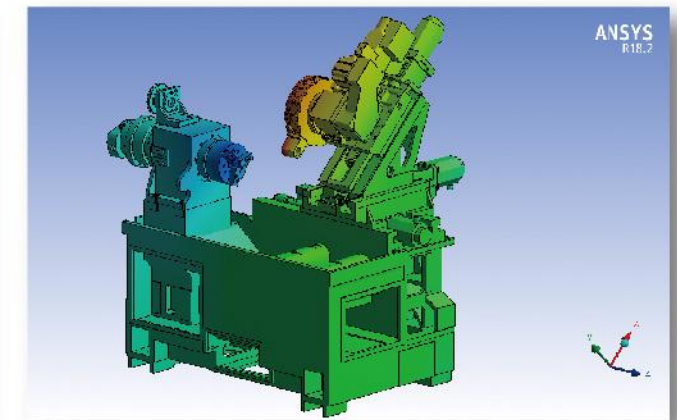

LTC-200MY

## CUTTING CAPACITY

### T-5iM

O.D. Cutting	
Cutting Speed	220m/min
Spindle Speed	810rpm
Feed Rate	0.25mm/rev
Depth of Cut	2.5mm
Removal Rate	138c.c/min

Drilling	
Tool Size	20mm
Spindle Speed	1500rpm
Feed Rate	0.12mm/rev
Depth of Cut	40mm

Groove Cutting	
Cutting Speed	140m/min
Spindle Speed	1393rpm
Feed Rate	0.15mm/rev
Depth of Cut	3mm

Tapping	
Tool Size	M16
Spindle Speed	500rpm
Feed Rate	2mm/rev
Depth of Cut	25mm



# FEATURE & QUALITY

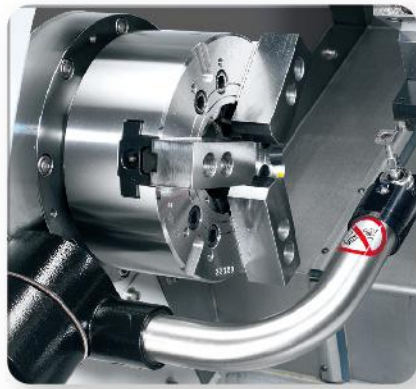

**Tool Setter (Optional)**  
The tool setter has a touch sensor that can measure various tool lengths and detect broken tools. It can be easily programmed to store all the tool information to reducing tool change time.



**Parts Catcher (optional)**

- Leadwell unique parts catcher improves productivity with the bar feeder option.
- The parts catcher automatically rotates to position under the finished part and transfers it outside the operator door. This eliminates the need to stop the machine and retrieve the finished parts.



**Bar Feeder (optional)**

The bar feeder is suggested for unattended bar machining and high production requirements. It handles bars ranging from 5 to 65 mm. in diameter. Bar loading can be quickly accomplished. Easy parameter setting for various bar sizes.

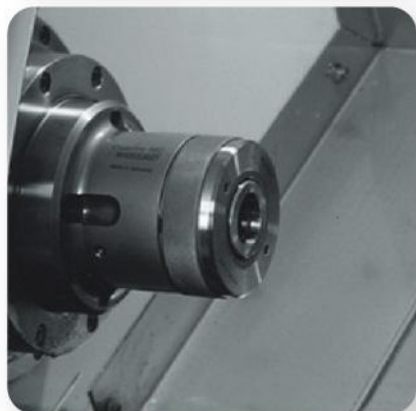

**Collet Chuck (optional)**

The spindle is available to mount with a collet chuck, providing faster chucking for bar stock. Various sizes of collet are supplied upon customers' request.

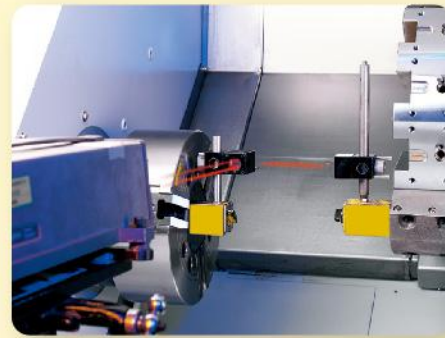

**LASER CALIBRATION**

Lasers are used to measure the positioning accuracy of every machine over the full travel of each axis. Leadwell uses these measurements to compensate any axis error so that each machine meets the high accuracy requirements.

- Each machine is shipped with a positioning accuracy chart.

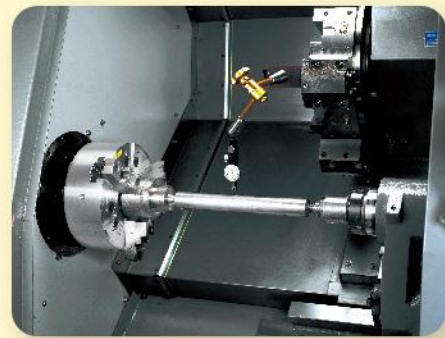

**MACHINE GEOMETRIC CHECKING**

Precision indicators are used to verify that spindle run-out and headstock to tailstock alignment meet all specifications.



**CUTTING AND COOLANT TESTING**

Each machine must complete rigorous cutting tests to ensure machine integrity. Coolant tests guarantee that all components are working properly and machines are 100% leak proof.

**48 HRS NON-STOP RELIABILITY TEST**

Each machines is cycled for 48 hrs to ensure the highest reliability

# SPINDLE POWER CURVE

- Torque-S1
- Torque-S3-40%
- Output-S1
- Output-S3-40%
- Torque-S3-25%
- Output-S3-25%

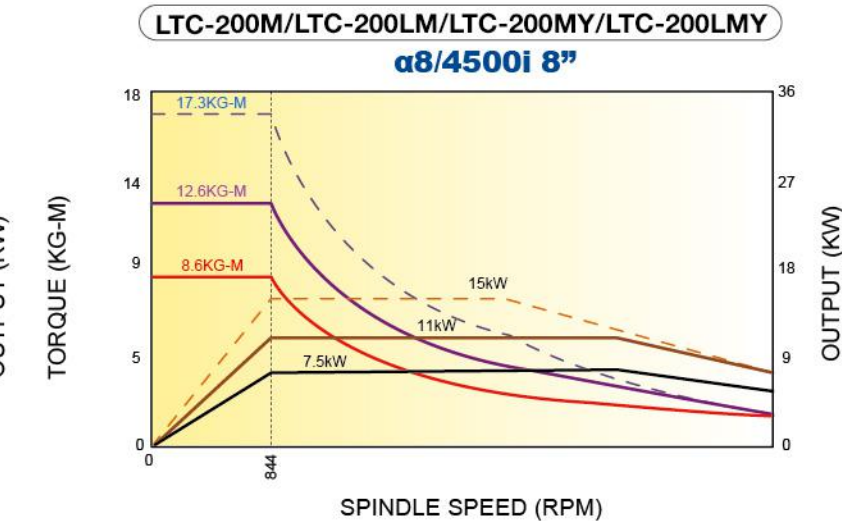
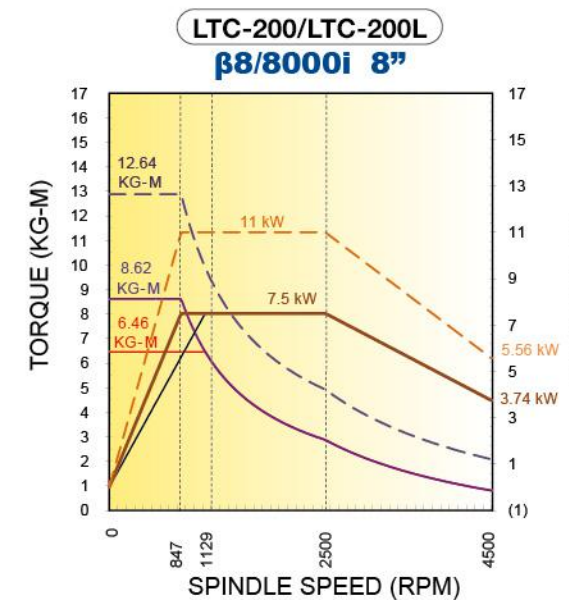
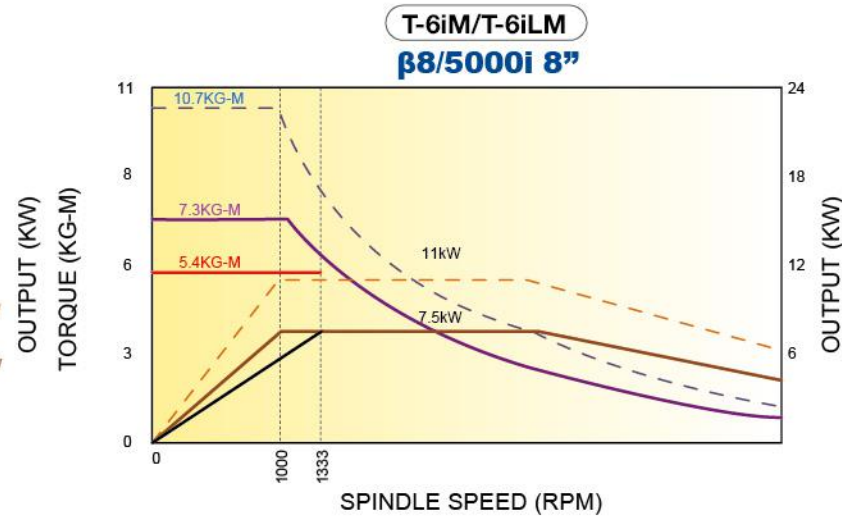
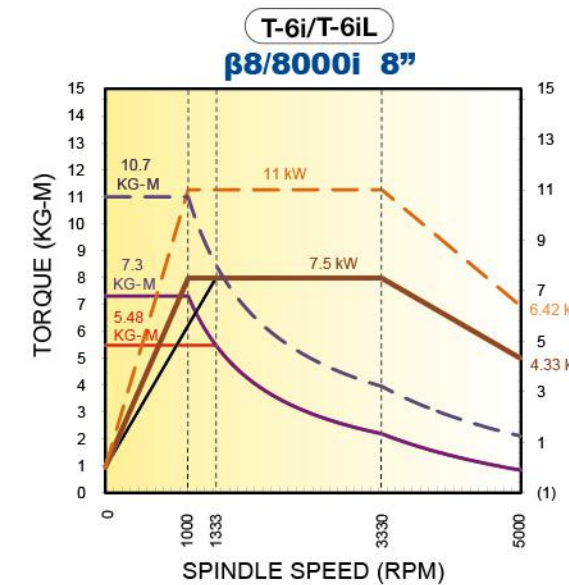
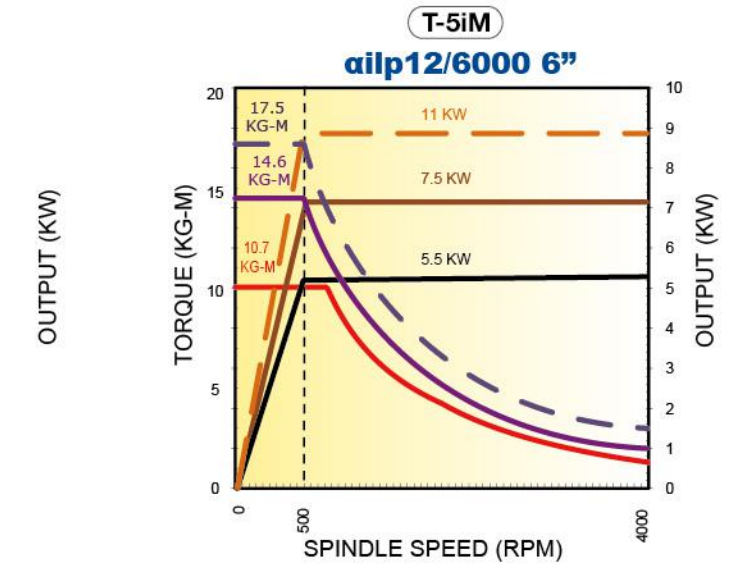
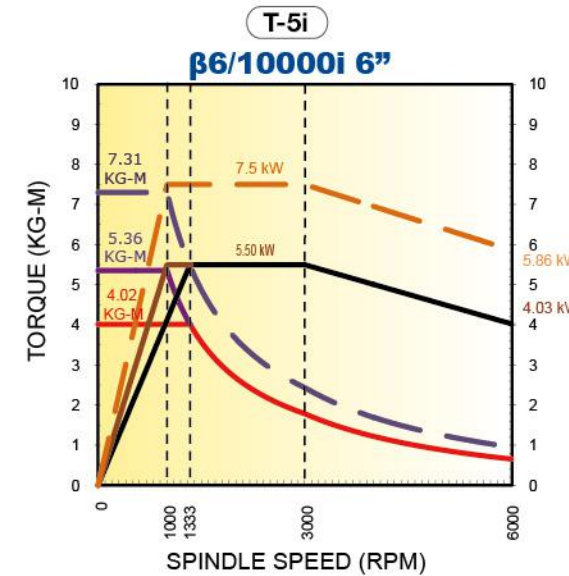



# OUTLINE DIMENSION

**T-5i/T-5iM**

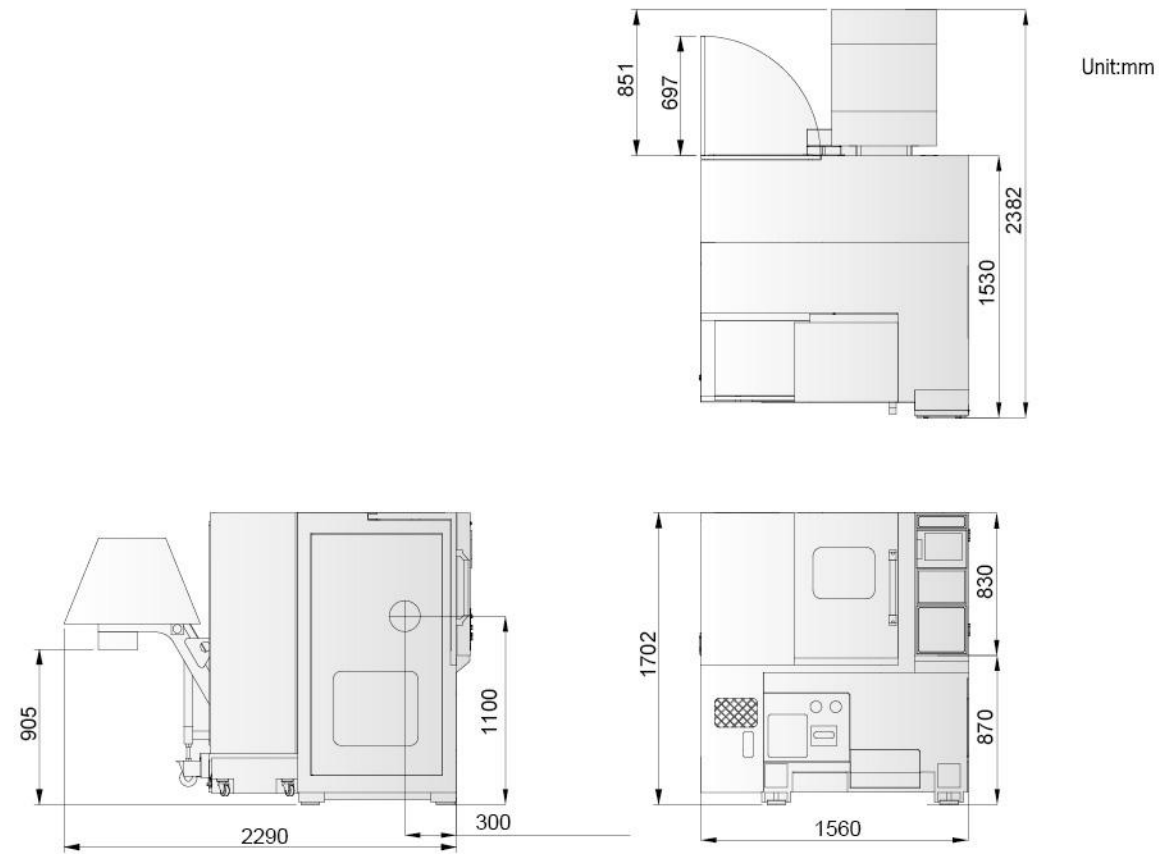

**T-6i/T-6iL  
LTC-200/LTC-200L**

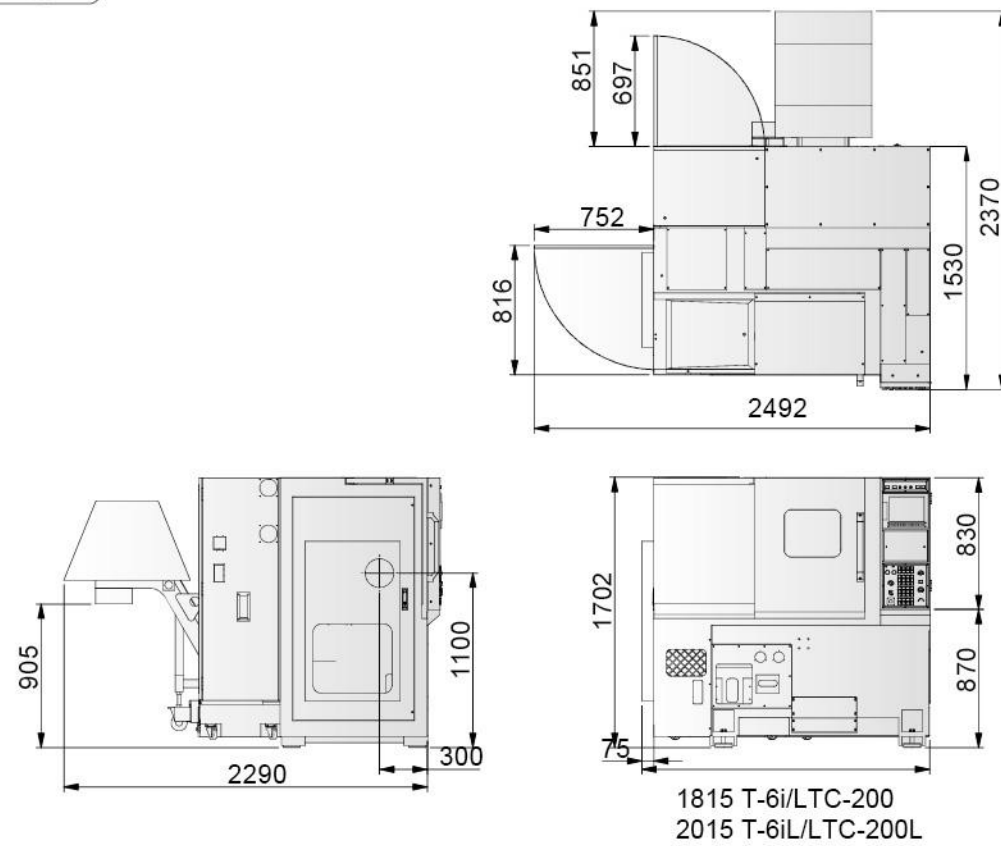

# OUTLINE DIMENSION

**T-6iM/T-6iLM  
LTC-200M/LTC-200LM**

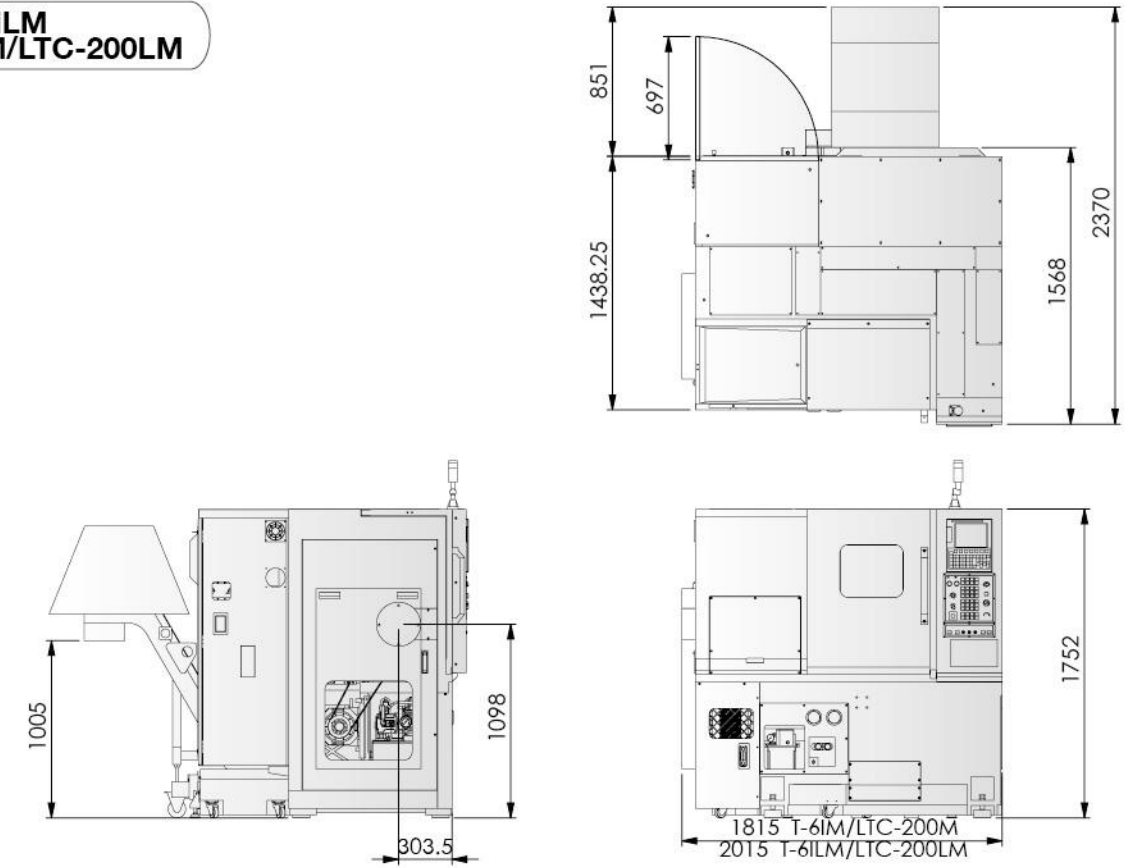

**LTC-200MY/LTC-200LMY**

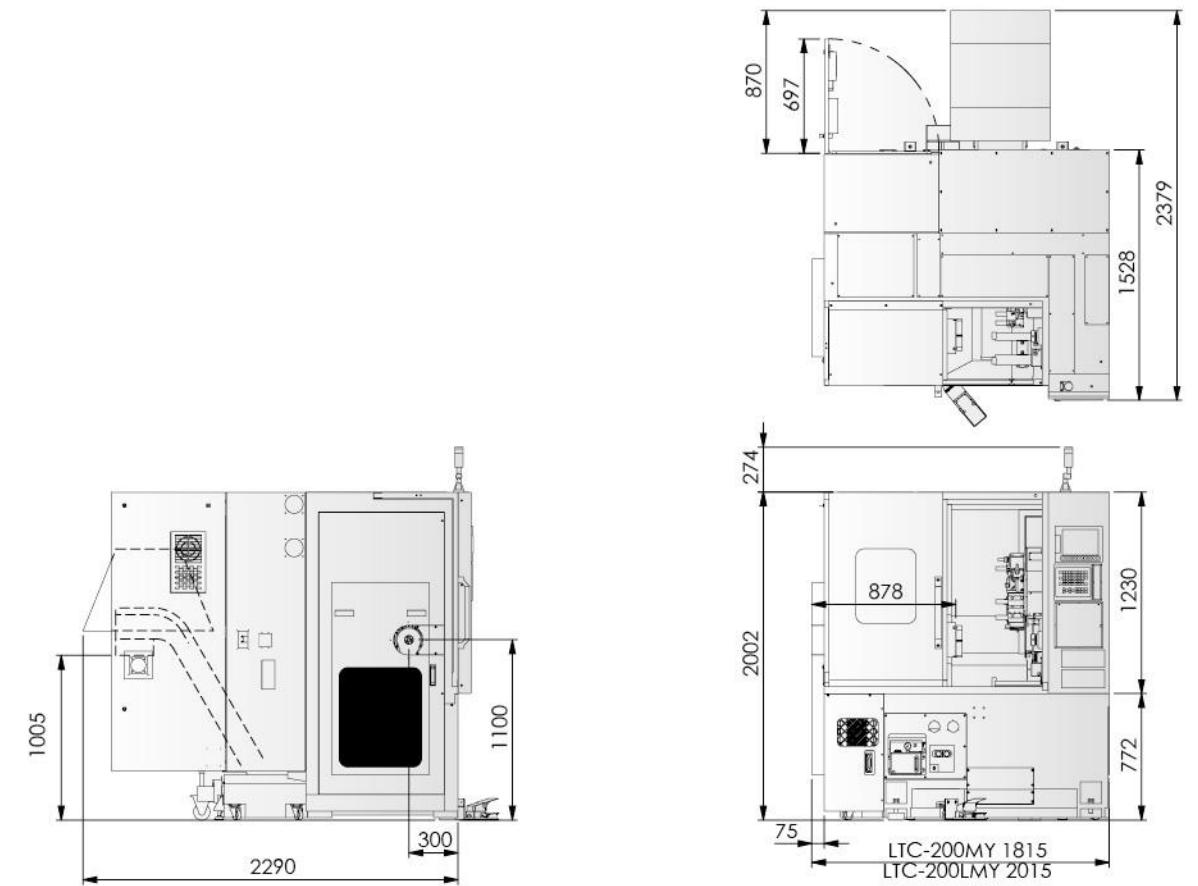

# TOOLING SYSTEM

## T-5i

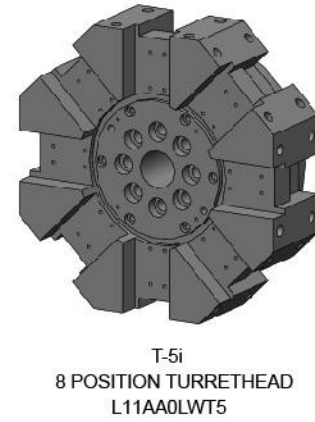
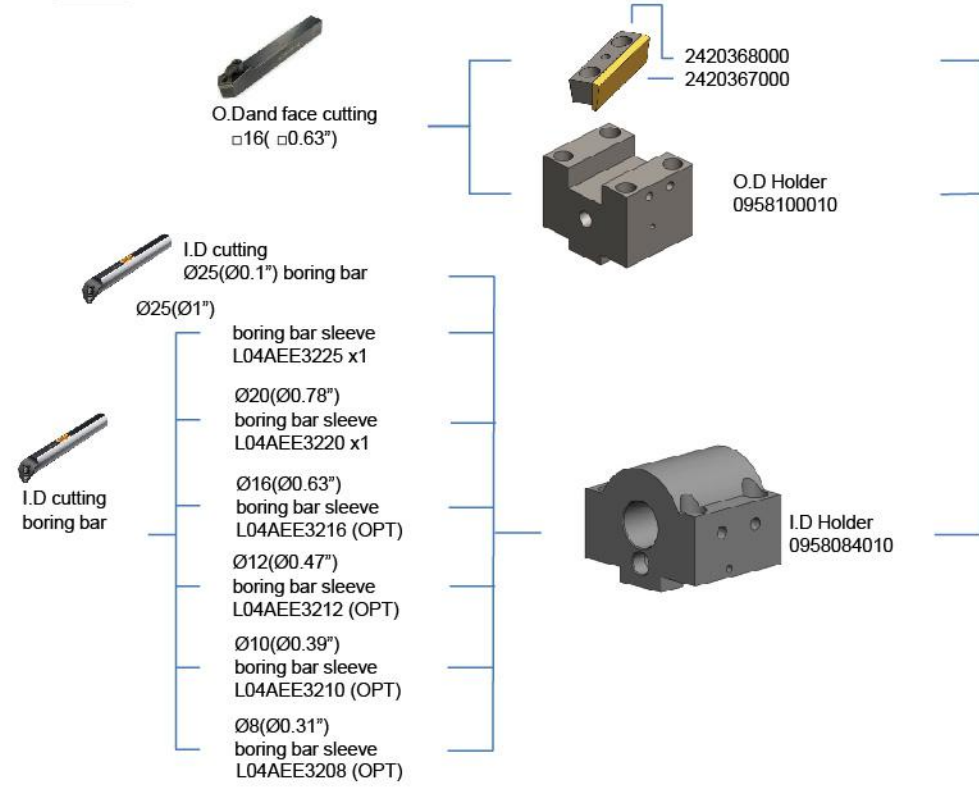

## T-5iM

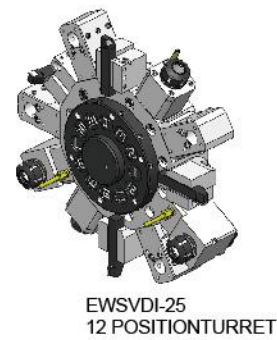
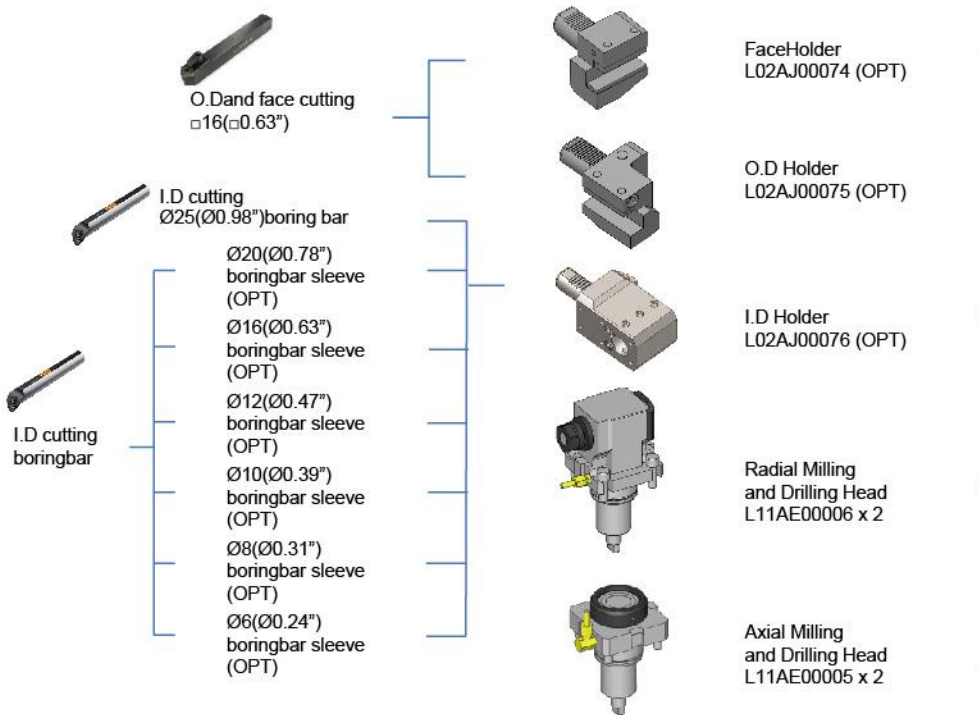

## T-6i/T-6iL

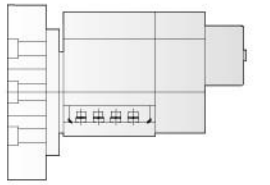
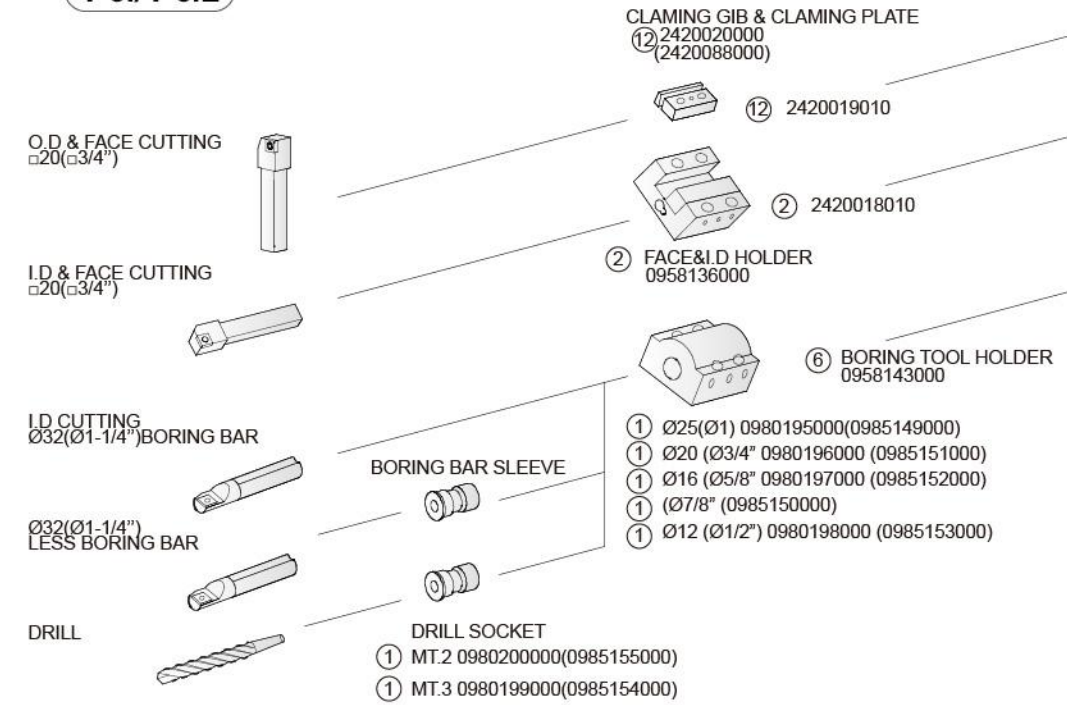

① TURRET ASSEMBLY  
L11AA0LWT6(L11AAELWT6)

O ; NO. OF STANDARD SET  
( ) ; Inch no.

## LTC-200/LTC-200L

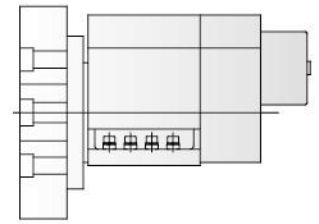
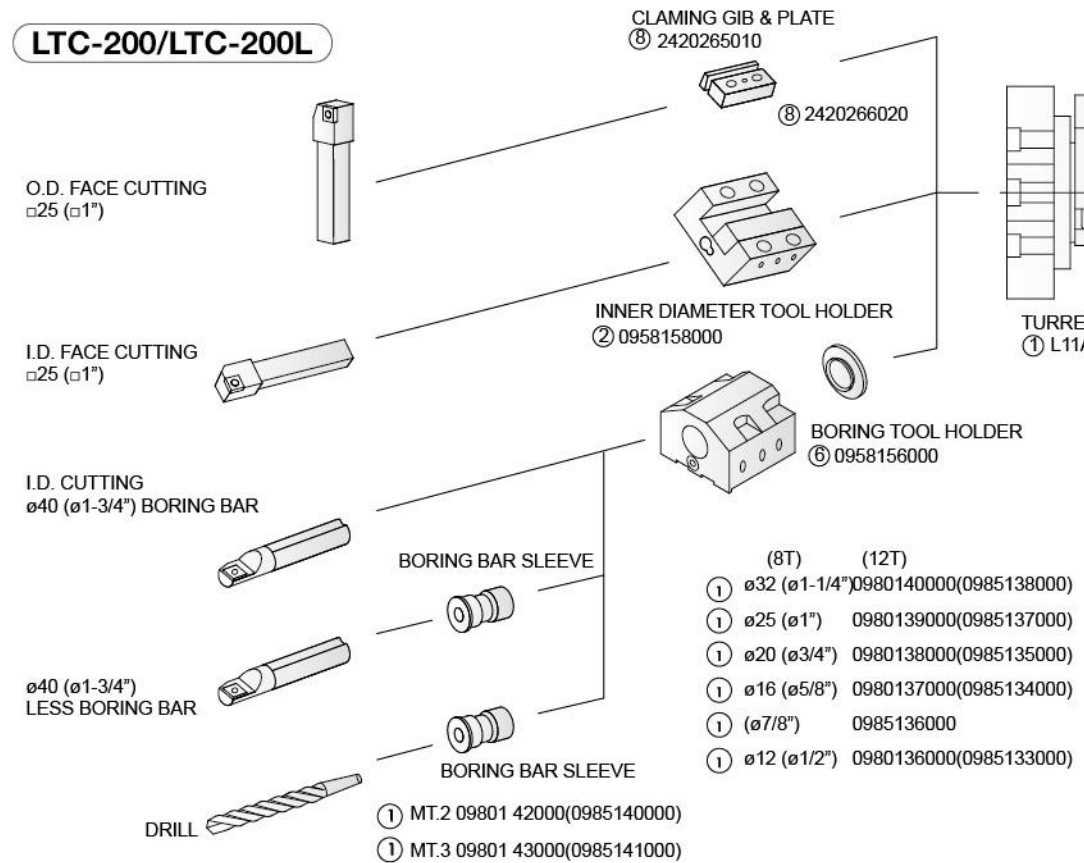

TURRET ASSEMBLY  
① L11AA0T6S8



# TOOLING SYSTEM

T-6iM/T-6iLM

LTC-200M/LTC-200LM

LTC-200MY/LTC-200LMY

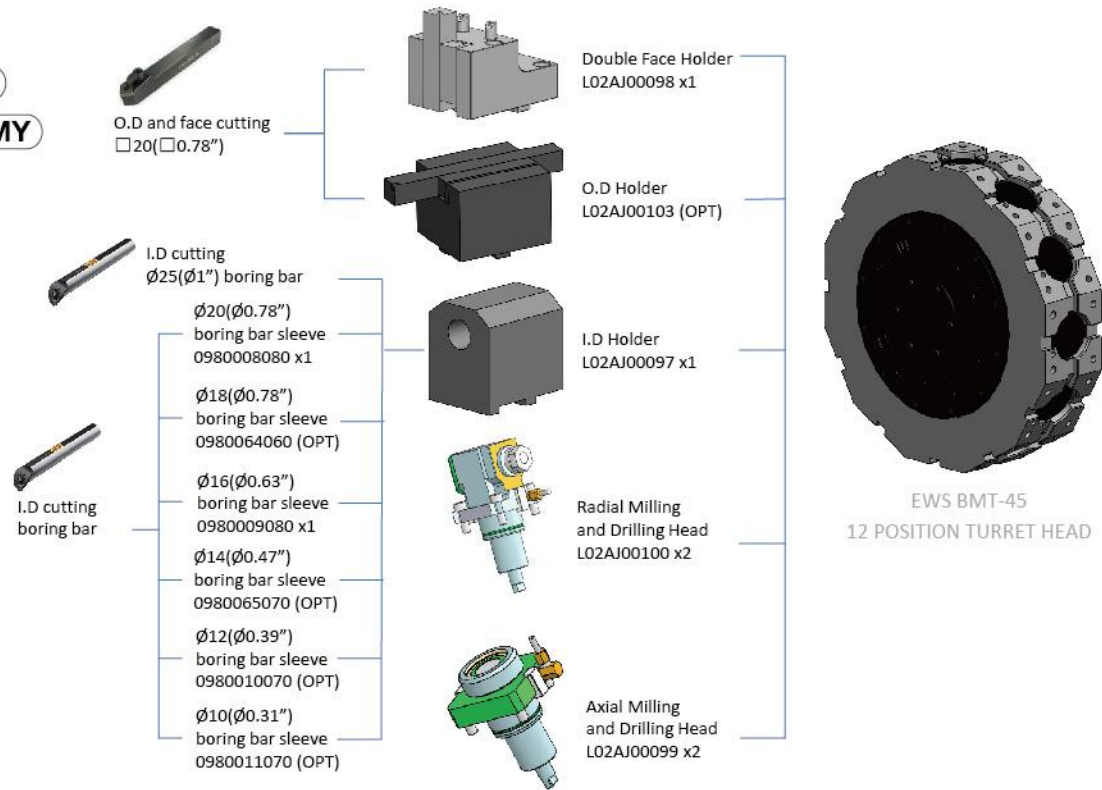

# TOOLING INTERFERENCE

T-5i

8 TOOLS

10 TOOLS

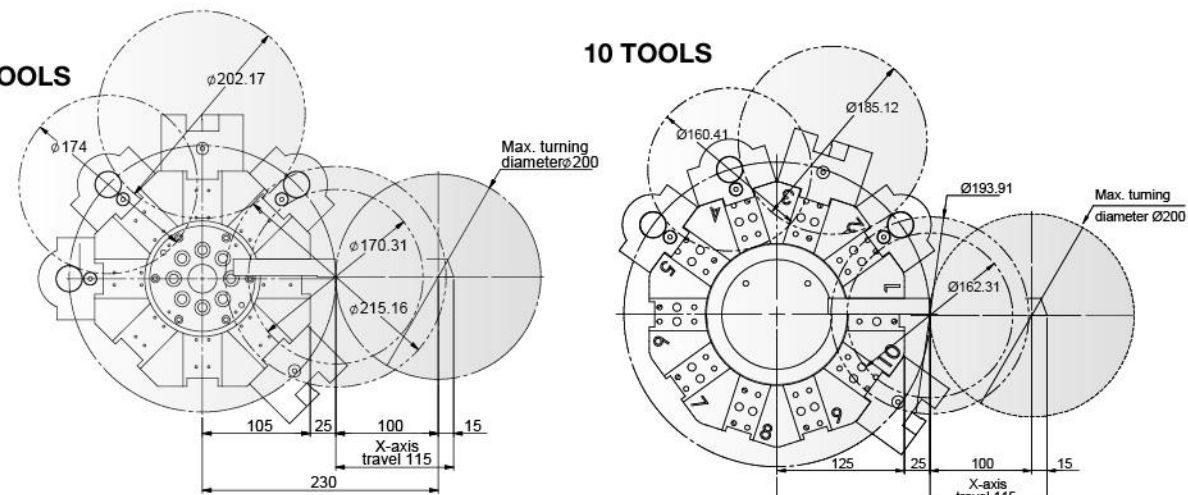

T-5iM

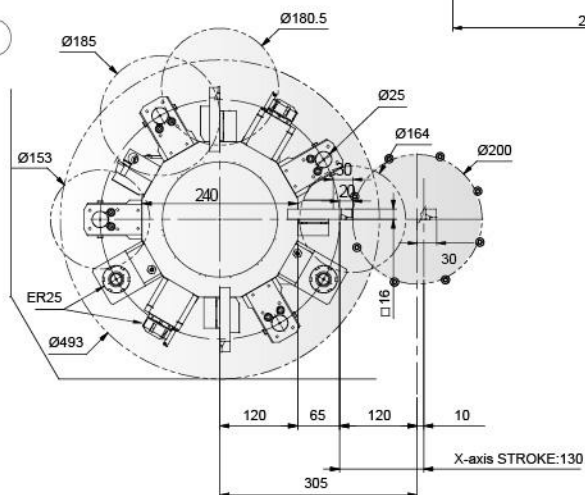

# TOOLING INTERFERENCE

T-6i/T-6iL

T-6iM/T-6iLM

LTC-200M/LTC-200LM

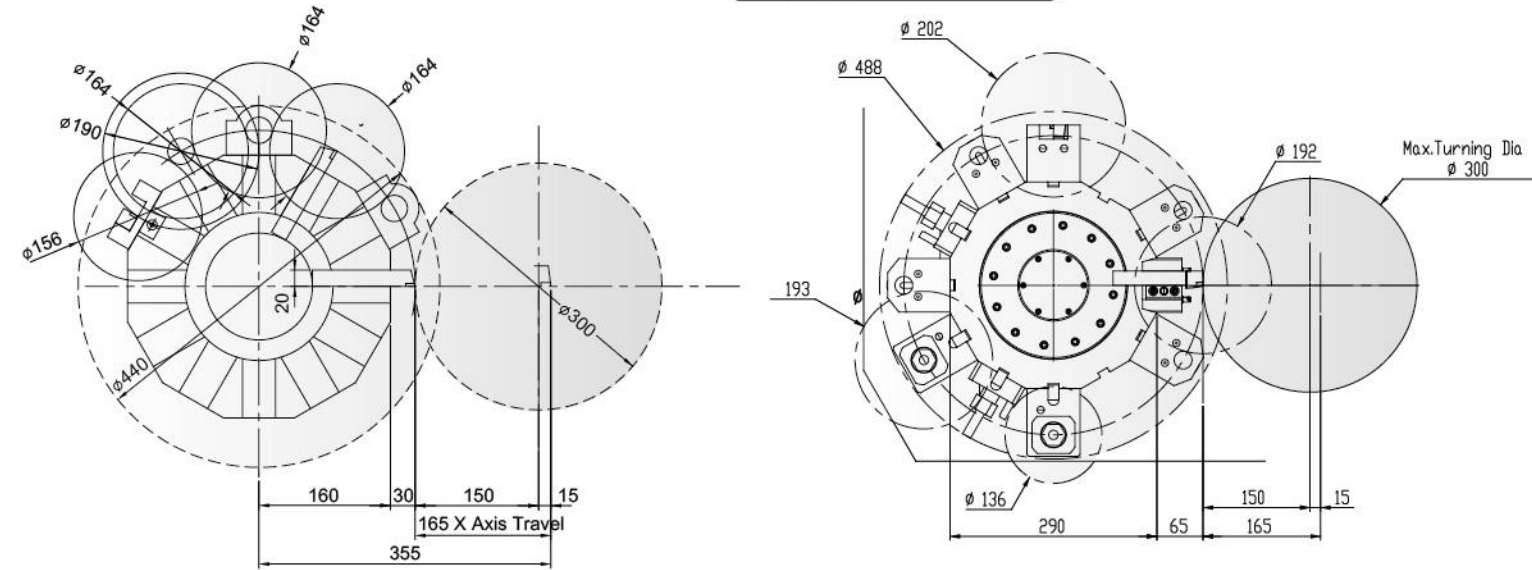

LTC-200/LTC-200L

LTC-200MY/LTC-200LMY

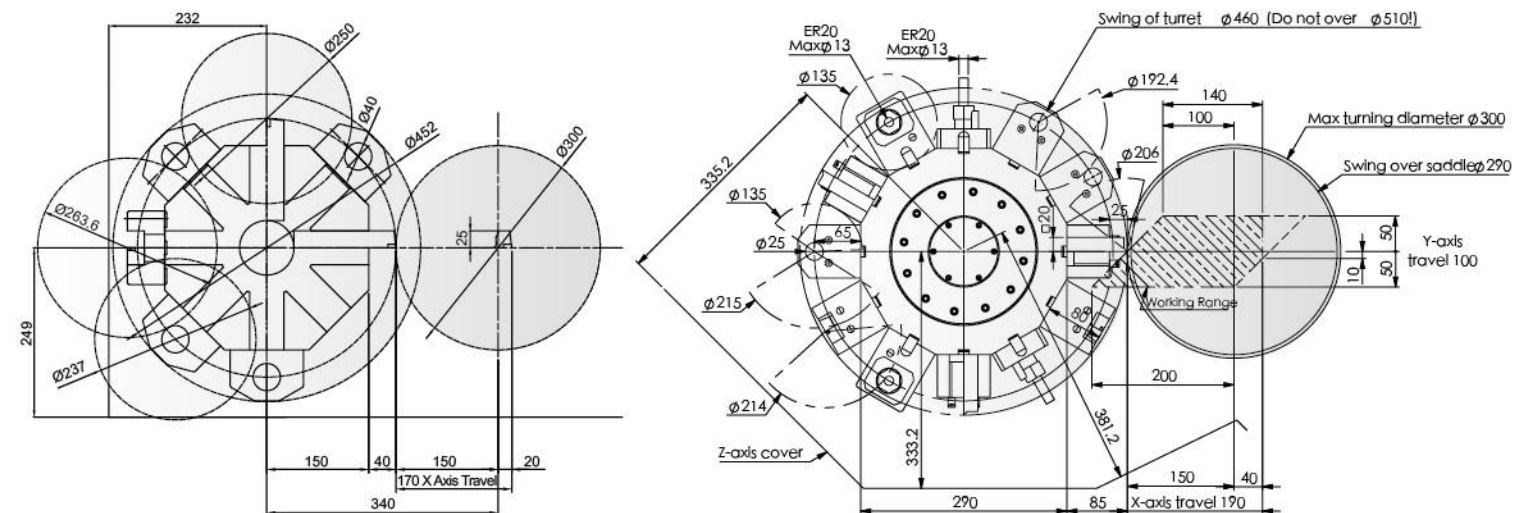



# WORKING CAPACITY

## T-5i

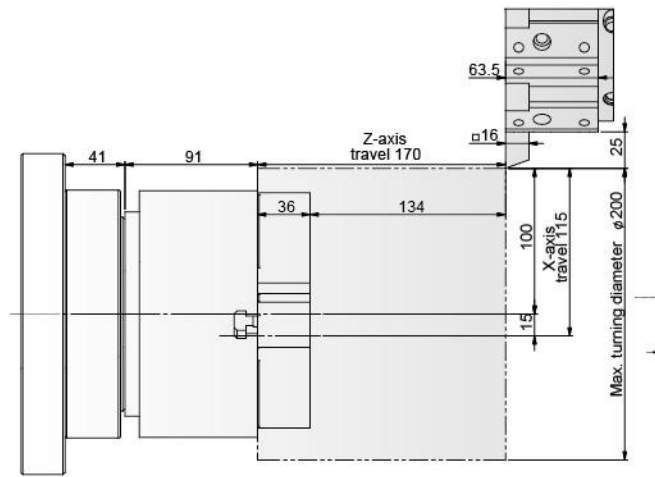

## T-5iM

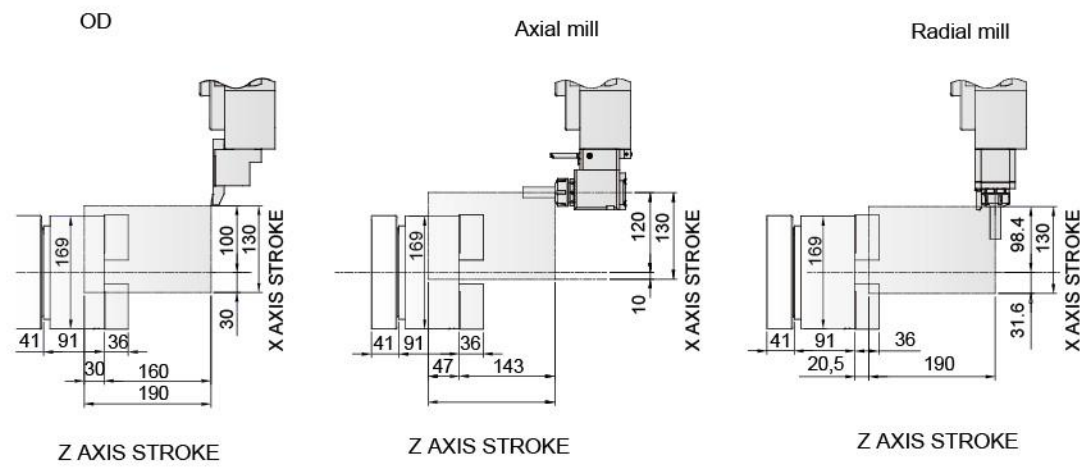

## T-6i/T-6iL

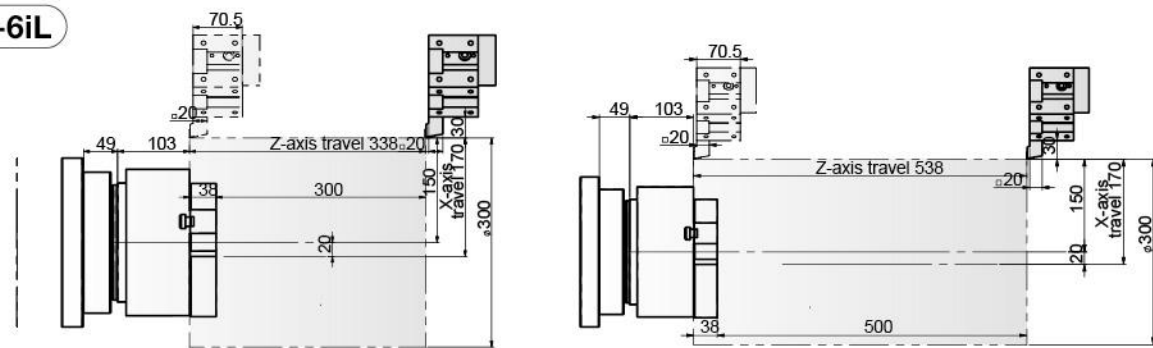

# WORKING CAPACITY

## LTC-200/LTC-200L

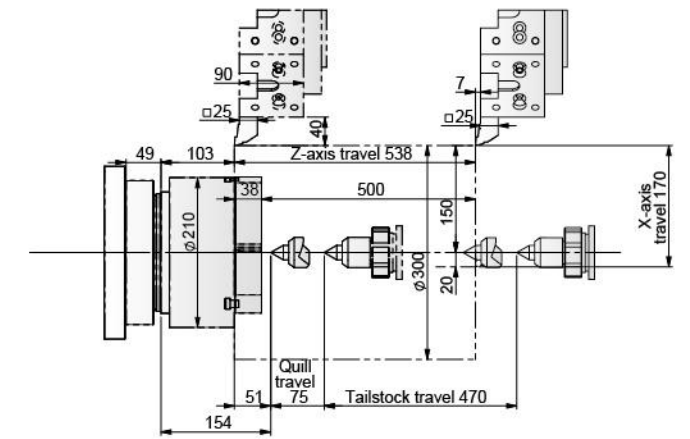
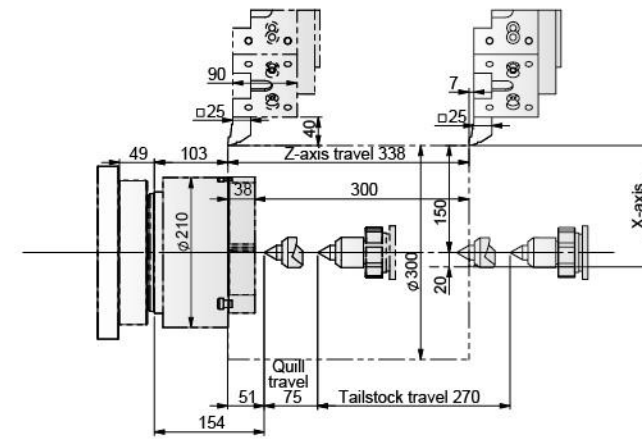

## T-6iM/T-6iLM

## LTC-200M/LTC-200LM

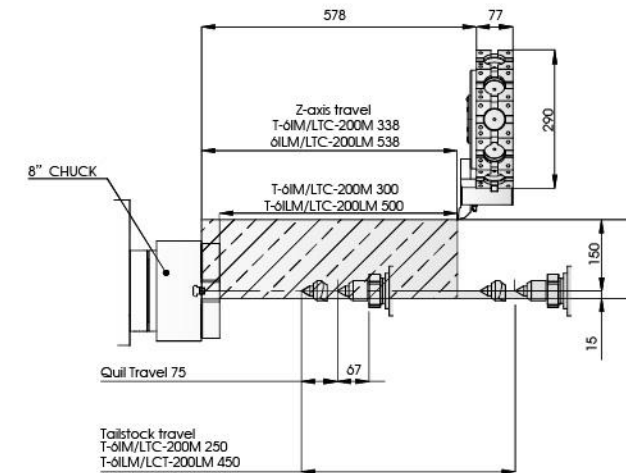

## LTC-200MY/LTC-200LMY

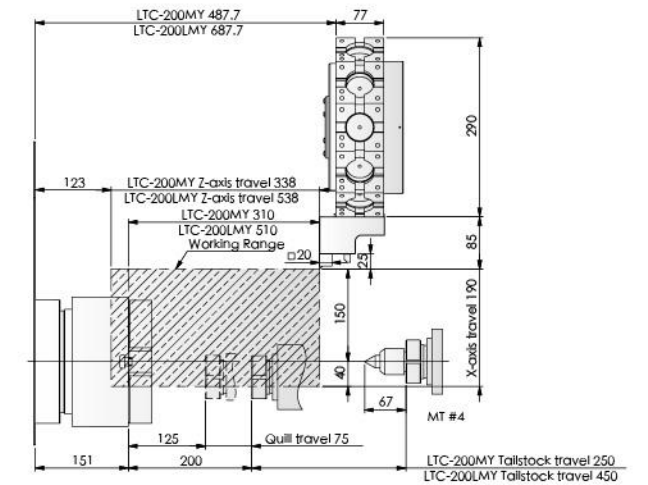

## LTC-200MY/LTC-200LMY

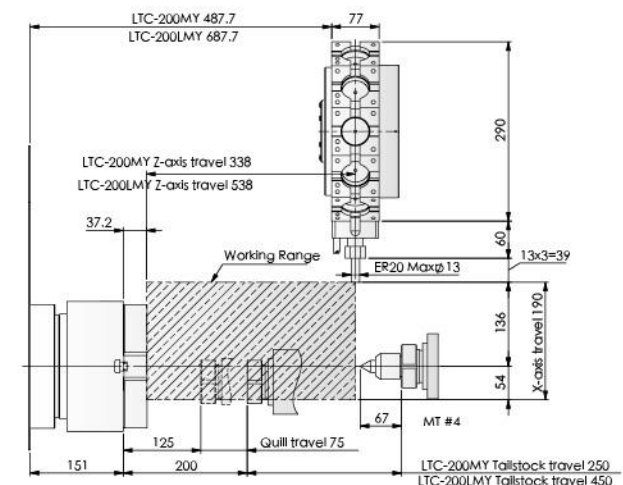
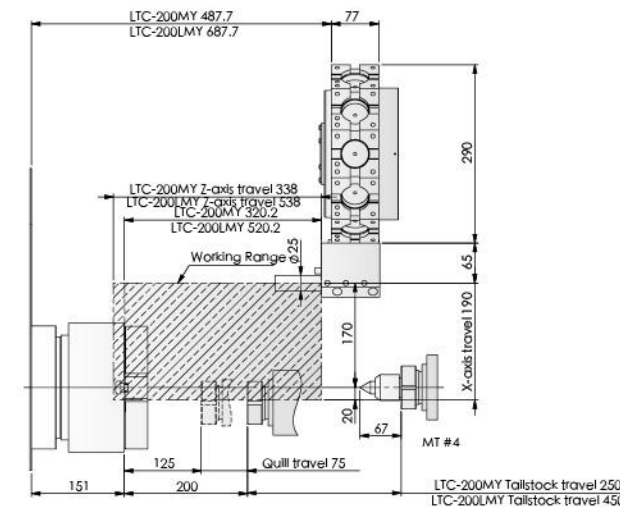



# MACHINE SPECIFICATIONS

ITEM	MODEL	T-5i	T-5iM	T-6i/T-6iL	T-6iM/T-6iLM
<b>CAPACITY</b>	Unit	Gang type/with Turret			
Max. swing	mm(in)	480(18.9)			
Max. turning diameter	mm(in)	136/300(5.35/11.8)	200(7.8)	300(11.8)	300(11.8)
Max. turning length	mm(in)	150(5.9)	150(5.9)	300/500(11.8/19.7)	
Bar capacity	mm(in)	45(1.77)	45(1.77)	45(1.77)	45(1.77)
<b>TRAVEL</b>					
X axis travel	mm(in)	230/150+15(9/5.9+0.6)	120+10(4.7+0.4)	150+15 (5.9+0.6)	150+15(5.9+0.6)
Z axis travel	mm(in)	230/186(9/7.32)	190(7.48)	338/538(13.3/21.2)	
<b>SPINDLE</b>					
Spindle speed	rpm	6000	4000	5000	5000
Chuck size	in	6			
Type of spindle nose		A2-5			
Spindle motor type	FANUC	β6/10000i	αiP12-6000	β8/8000i	β8/5000i
Spindle motor power	kw(hp)	7.5(10)	5.5(7.4)	11(14.7)	11(14.7)
<b>TURRET</b>					
Number of tool stations	pcs	6/8	12	12	12
Shank height for square tool	mm(in)	16(0.63)	16(0.63)	20(0.78)	20(0.78)
Shank diameter for boring bar	mm(in)	25(1)	25(1)	32(1.25)	25(1)
<b>FEED RATE</b>					
X/Z axis rapid traverse	m(in)/min	30(1181)			
<b>FEED MOTORS</b>					
X/Z axis motor	kw(hp)	1.2(1.6)	1.6(2.1)	1.6(2.1)	1.6(2.1)
<b>TAILSTOCK</b>					
Quill diameter	mm(in)	---	---	75(3)	75(3)
Quill inside taper	M.T	---	---	4	4
<b>MACHINE SIZE</b>					
Height of machine (H)	mm(in)	1700(67)			
Floor space (LXW)	mm(in)	1560x1555(61.4X61.2) 1560x1530(61.4X60.2)	1560X1530(61.4X60.2)	1815/2015X1530 (71.5/79.3)X60.2	1815/2015X1581 (71.5/79.3)X62.2
Total machine weight	kg	2700	3000	3500/3800	3500/3800
Power requirement	KVA	15	15	20	25
Controller	FANUC	0i-T	0i-T	0i-T	0i-T

\*AVAILABLE CONTROLLER: SIEMENS

## STANDARD ACCESSORIES

- Buzzer
- Heat exchanger
- Full enclosed splash guard
- 3 jaw open center chuck
- Foot switch
- Wide angle V-belt
- Manual tailstock
- Leveling screws and pads
- Maintenance tool box
- Work light

## OPTIONAL ACCESSORIES

- 3 jaw close center chuck
- Auto door
- Main Spindle air outer blow
- Air conditioner
- Bar feeder
- Chip conveyor
- Chip bucket
- Collet chuck
- High pressure pump
- Inch disc
- Oil mist collector
- Oil skimmer
- Parts catcher
- Programmable tailstock
- Robot
- Transformer
- Tool setter

# MACHINE SPECIFICATIONS

ITEM	MODEL	LTC-200/LTC-200L	LTC-200M/LTC-200LM	LTC-200MY/LTC-200LMY
<b>CAPACITY</b>	Unit			
Max. swing	mm(in)	500(19.7)		
Max. turning diameter	mm(in)	300(11.8)		
Max. turning length	mm(in)	300/500(11.8/19.7)		
Bar capacity	mm(in)	52(2)		
<b>TRAVEL</b>				
X axis travel	mm(in)	150+20(5.9+0.7)	150+15(5.9+0.6)	150+40(5.9+1.6)
Z axis travel	mm(in)	338/538(13.3/21.2)	338/538(13.3/21.2)	338/538(13.3/21.2)
<b>SPINDLE</b>				
Spindle speed	rpm	4500		
Chuck size	in	8		
Type of spindle nose		A2-6		
Spindle motor type	FANUC	β8/8000i		
Spindle motor power	kw(hp)	11(14.7)		
<b>TURRET</b>				
Number of tool stations	pcs	8	12	12
Shank height for square tool	mm(in)	25(1)	20(0.78)	20(0.78)
Shank diameter for boring bar	mm(in)	40(1.6)	25(1)	25(1)
<b>FEED RATE</b>				
X/Z axis rapid traverse	m(in)/min	20(788)	20(788)	20(788)
<b>FEED MOTORS</b>				
X/Z axis motor	kw(hp)	1.6(2.1)	1.6(2.1)	2.7(3.6)
<b>TAILSTOCK</b>				
Quill diameter	mm(in)	75(3)		
Quill inside taper	M.T	4		
<b>MACHINE SIZE</b>				
Height of machine (H)	mm(in)	1700(67)	1752(68.9)	2000(78.7)
Floor space (LXW)	mm(in)	1815/2015X1530 (71.5/79.3X60.2)	1815/2015X1581(71.5/79.3X62.2)	1815/2015X1530(71.5/79.3X60.2)
Total machine weight	kg	3600/3900	3600/3900	3900/4200
Power requirement	KVA	20	25	30
Controller	FANUC	0i-T	0i-T	0i-T

\*AVAILABLE CONTROLLER: SIEMENS

## STANDARD ACCESSORIES

- Buzzer
- Heat exchanger
- Full enclosed splash guard
- 3 jaw open center chuck
- Foot switch
- Wide angle V-belt
- Manual tailstock
- Leveling screws and pads
- Maintenance tool box
- Work light

## OPTIONAL ACCESSORIES

- 3 jaw close center chuck
- Auto door
- Main Spindle air outer blow
- Air conditioner
- Bar feeder
- Chip conveyor
- Chip bucket
- Collet chuck
- High pressure pump
- Inch disc
- Oil mist collector
- Oil skimmer
- Parts catcher
- Programmable tailstock
- Robot
- Transformer
- Tool setter