

**TEST REPORT No. 362347**

Customer

**AKOS DIŞ TICARET LIMITED ŞİRKETİ**

Fevzi Çakmak Mahallesi, Ayyıldız Caddesi No: 4 - 42050 KARATAY - KONYA - Turkey

Item\*

**railing named "ALUSMART A11"**

Activity

**resistance to outward horizontal static loading  
and resistance to dynamic impact in according to  
standards NF P01-013:1988 and UNI EN 14019:2016**

Results

Test	Result
outward horizontal static loading for use private (1,3 kN/m)	<b>compliant</b>
outward horizontal static loading for use public (1,0 kN/m)	<b>compliant</b>
dynamic impact with 50 kg soft body	<b>compliant</b>
dynamic impact with 50 kg semi-rigid body	<b>compliant</b>

(\*) according to that stated by the customer.

Bellaria-Igea Marina - Italy, 18 June 2019

Chief Executive Officer

Order:  
80243Item origin:  
sampled and supplied by the customerIdentification of item received:  
2019/1383/D dated 4 June 2019Activity date:  
13 June 2019Activity site:  
Istituto Giordano S.p.A. - Strada Erbosa Uno, 72 -  
47043 Gatteo (FC) - Italy

Contents	Page
Description of item*	2
Normative references	4
Apparatus	4
Method	5
Environmental conditions	5
Results	6
Findings	7

This document is made up of 7 pages and shall not be reproduced except in full without extrapolating parts of interest at the discretion of the customer, with the risk of favoring an incorrect interpretation of the results, except as defined at contractual level.

The results relate only to the item examined, as received, and are valid only in the conditions in which the activity was carried out.

The original of this document consists of an electronic document digitally signed pursuant to the applicable Italian Legislation.

Chief Test Technician:

Dott. Andrea Bruschi

Head of Security and Safety Laboratory:

Dott. Andrea Bruschi

Compiler: Francesca Manduchi

Reviewer: Dott. Andrea Bruschi

Page 1 of 7

**Description of item\***

The item under examination consists of laminated tempered glass railing with aluminium structure, having the following characteristics:

<b>Overall width</b>	1000 mm
<b>Overall height from floor</b>	1000 mm
<b>Glass type</b>	laminated glass 8.8.4 (tempered + PVB +tempered)
<b>Dimension of glass</b>	1000 mm × 1000 mm

Further details of item specifications can be seen in customer-supplied schematic drawings shown on the following page.



**Photographs of the item**

(\*) according to that stated by the customer; Istituto Giordano declines all responsibility for the information and data provided by the customer that may influence the results.

**SCHEMATIC DRAWINGS OF ITEM SUPPLIED BY THE CUSTOMER**

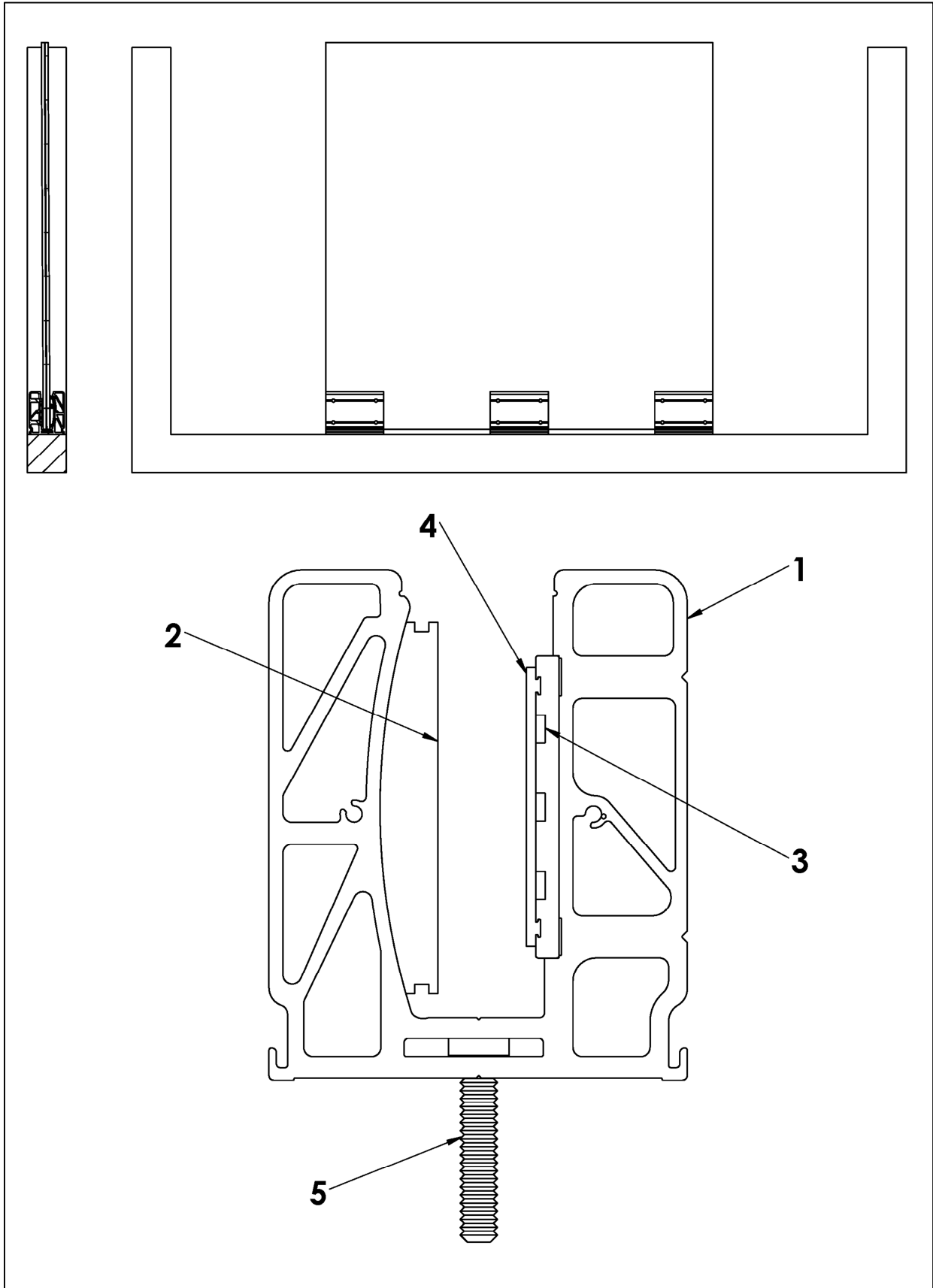



LAB N° 0021 L

### Normative references

Document	Title
NF P01-013:1988	Essais des garde-corps. Méthodes et critères ( <i>Railing tests. Methods and criteria</i> )
NF P08-301:1991	Ouvrages verticaux des constructions - Essais de résistance aux chocs - Corps de chocs - Principe et modalités générales des essais de choc ( <i>Vertical building elements - Impact resistance tests - Impact bodies - Impact test principle and general methods</i> )
UNI EN 14019:2016	Curtain Walling - Impact resistance - Performance requirements

### Apparatus

#### Resistance to outward horizontal static loading

Description	In-house identification code
Steel frame simulating actual installation of the item on the floor	EDI048
No. 3 Gefran digital displacement transducers "PZ-34-S150", range of measurement 0 ÷ 150 mm	FT451/1, FT451/2 and FT451/3
Mitutoyo IDF Digimatic Indicator	//
AEP Transducers load cell "TS", range of measurement 0 ÷ 1 kN	EDI107
Würth telescopic measuring rod "mEssfix", range of measurement 0 ÷ 5000 mm and resolution 0,1 mm	EDI083
La Crosse Technology digital thermo-hygrometer "WS8009"	EDI111

#### Resistance to dynamic impact

Description	In-house identification code
Steel frame simulating actual installation of the item on the floor	EDI048
Soft body consisting of spheroconical bag, diameter 0,40 m and height 0,60 m, filled with hardened glass beads, diameter 3 mm, until reaching a total mass of 50 kg and suspended by an inextensible cable of negligible mass so that when hanging at rest it makes contact with the item at the desired point of impact	EDI062
Semi-rigid impactor, total mass 50 kg, complying with standard EN 12600:2002	EDI012



LAB N° 0021 L

## **Method**

Test was carried out using detailed internal procedure PP083 in its current revision at testing date. The item, secured to the floor, was subjected to the following test.

### **Resistance to outward horizontal static loading**

With just underside secured to the floor, the item was subjected to a load distributed uniformly over three points on the handrail in accordance with figure 2 “Garde-corps sans potelets, ancrés au niveau de l’appui” (*“Railings without posts anchored at the base”*) of standard NF P01-013:1988:

- preload of 0,7 kN applied gradually until reaching the present value and maintained for 3 min;
- removal of load and resetting of gauge;
- horizontal static load of 1,3 kN (1 kN/m) applied gradually until reaching the present value and maintained for 60 s, following which deflection whilst loaded was measured;
- removal of load and recording of permanent deflection after 3 min;
- horizontal static safety load of 2,21 kN with coefficient of 1,7 for aluminium, applied and maintained for 5 min, following which deflection whilst loaded was measured;
- removal of safety load and recording of permanent deflection after 3 min and verification of permissible permanent deflection following removal of safety load using the following equation:

$$a \leq \frac{8 \cdot X}{1000}$$

where: a = permissible permanent deflection following removal of safety load in mm.

X = height of item from fixing point in mm.

### **Resistance to dynamic impact**

With just underside secured to the floor, the item was subjected to two dynamic load with energy of 590 J (0,50 kN × 1,20 m) and 470 J (0,50 kN × 0,95 m).

All impacts were made by releasing the impactors so that they fall from a specified height with a pendulum movement and without initial velocity.

The impactors were hung by an inextensible pendulum wire of negligible mass so that when at rest they made contact with the point of intended impact.

After each impact, the impactors were prevented from hitting the item again after bouncing.

## **Environmental conditions**

<b>Temperature</b>	(29 ± 2) °C
<b>Relative humidity</b>	(50 ± 5) %

## Results

### Resistance to outward horizontal static loading

Applied load <sup>*</sup>	Deflection whilst loaded	Permanent deflection	Maximum permanent deflection <sup>**</sup>	Result
[kN]	[mm]	[mm]	[mm]	
1,30	76	3	//	//
2,21 <sup>***</sup>	175	8	8	pass

(\*) in accordance with clause 2.2.1.2 "Description de l'essai" ("Description of the test") of standard NF P01-013:1988.

(\*\*) permissible permanent deflection "a" calculated in accordance with clause 2.2.1.2.4 "Déformation admissible des garde-corps métalliques" ("Permissible deflection of metal railings") of standard NF P01-013:1988.

(\*\*\*) safety load with coefficient of 1,7 for aluminium.

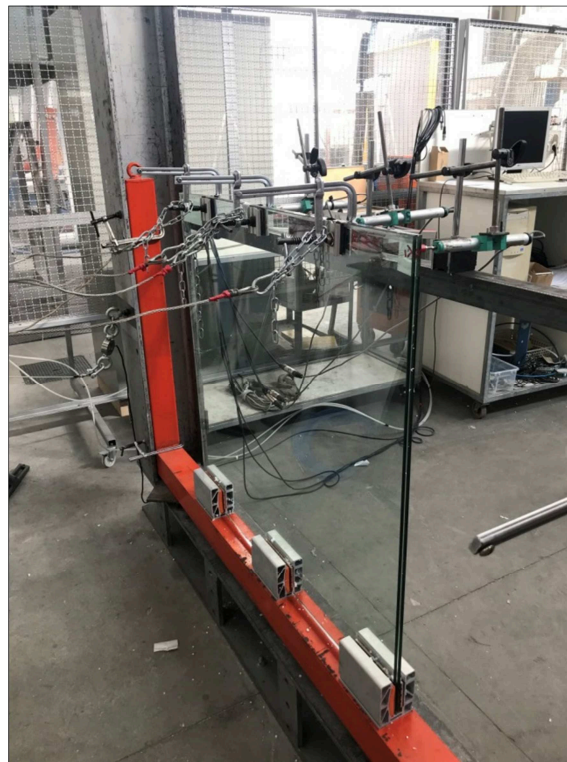

Photograph of the item after the horizontal static loading test

### Resistance to dynamic impact according to standard NF P08-301:1991

Impact area	Drop height	Energy	Result
	[m]	[J]	
center of glass	1,2	590	no damage <sup>*</sup>
upper edge of the glass	1,2	590	no damage <sup>**</sup>

(\*) No falling fragments that could cause personal injury were found below.

No gaps were formed between the bars of sufficient size to allow the passage of the gauge specified in figure 7 of standard NF P01-013:1988.

No item performance loss compared to design specifications was witnessed.

**Resistance to dynamic impact according to standard UNI EN 14019:2016**

Impact area	Drop height [m]	Energy [J]	Result
center of glass	0,95	470	no damage*
upper edge of the glass	0,95	470	no damage*

(\*) no parts exceeding the mass of 50g shall fall down;

no holing shall occur permitting a test block E2 according with EN 1630 (ellipse) to be passed through it;

no permanent deformation of sample, including their connections and fixings, shall be accepted as far as no fracturing or rupturing that separates any framing member, connection or fixing into two or more fragments shall occur;

the test specimen shall not detach or dislodge;

any infill panels shall not detach or dislodge.



**Photographs of the item after the impacts**

**Findings**

Test	Result*
outward horizontal static loading for private public (1,3 kN/m)	<b>compliant</b>
outward horizontal static loading for use public (1,0 kN/m)	<b>compliant</b>
dynamic impact with 50 kg soft body	<b>compliant</b>
dynamic impact with 50 kg semi-rigid body	<b>compliant</b>

(\*) the compliance has been determined on the basis of values obtained by measurements during testing in line with clause 2.6 of ILAC-G8:03/2009 "Guidelines on the reporting of compliance with specification", having satisfied the requirements on measurements and equipment defined in the reference normative.

Chief Test Technician  
(Dott. Andrea Bruschi)

Head  
of Security and Safety Laboratory  
(Dott. Andrea Bruschi)

*Andrea Bruschi*

*Andrea Bruschi*