



PLASTIC PELLET
EXTRUSION SYSTEMS

lima®
extrusion
a lider makina company

lima.
extrusion
a lider makina company



OVER 30
YEARS OF
EXCELLENCE

A white industrial machine with a control panel on the left and a large circular component on the right. The control panel has a screen, a yellow emergency stop button, and a vertical stack of four colored lights (red, orange, green, yellow). The machine is set against a solid blue background.

lima.
extrusion
a lider makina company



A collection of small, cylindrical yellow PVC pellets scattered on a bright blue background. The pellets are concentrated on the left side of the image, with a few isolated pellets on the right.

lima[®] extrusion

SOLUTIONS FOR COST-EFFECTIVE PRODUCTION AND PREMIUM QUALITY PRODUCTS.

Focusing on reliable, efficient and high performance systems as a result of market's circumstances and production conditions, Lima Extrusion targets to provide the optimal solutions for the customer's needs for rigid and soft PVC pelletizing extrusion.

CAN BE CUSTOMIZED TO THE APPLICATION REQUIREMENTS

VIBRATION COOLING UNIT

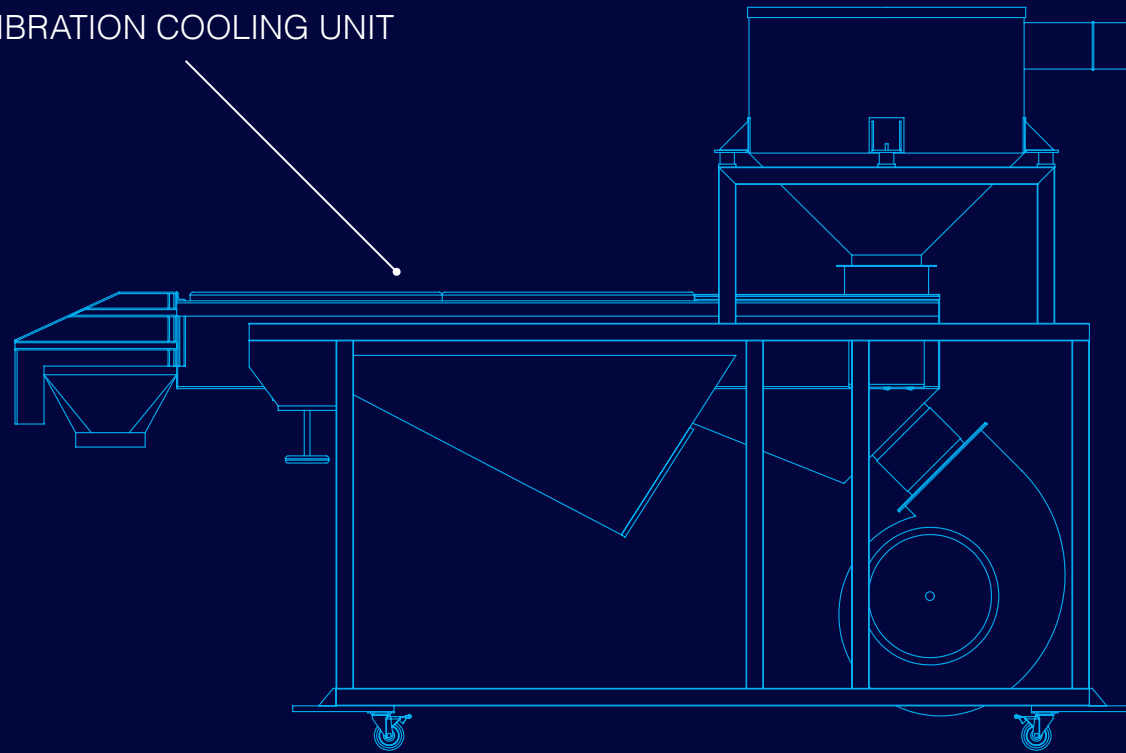

HEAD WITH CUTTING UNIT

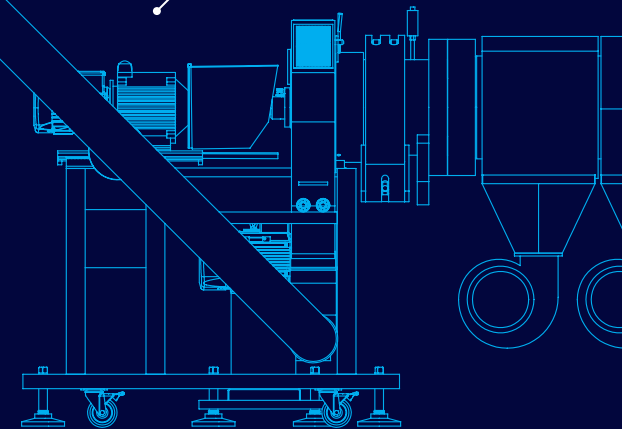

lima[®] extrusion PELLET EXTRUSION LINE

PARALLEL TWIN SCREW EXTRUDER	6
HEAD WITH CUTTING UNIT	8
VIBRATION COOLING UNIT	10
AUXILIARY EQUIPMENT	12

PARALLEL TWIN SCREW EXTRUDER

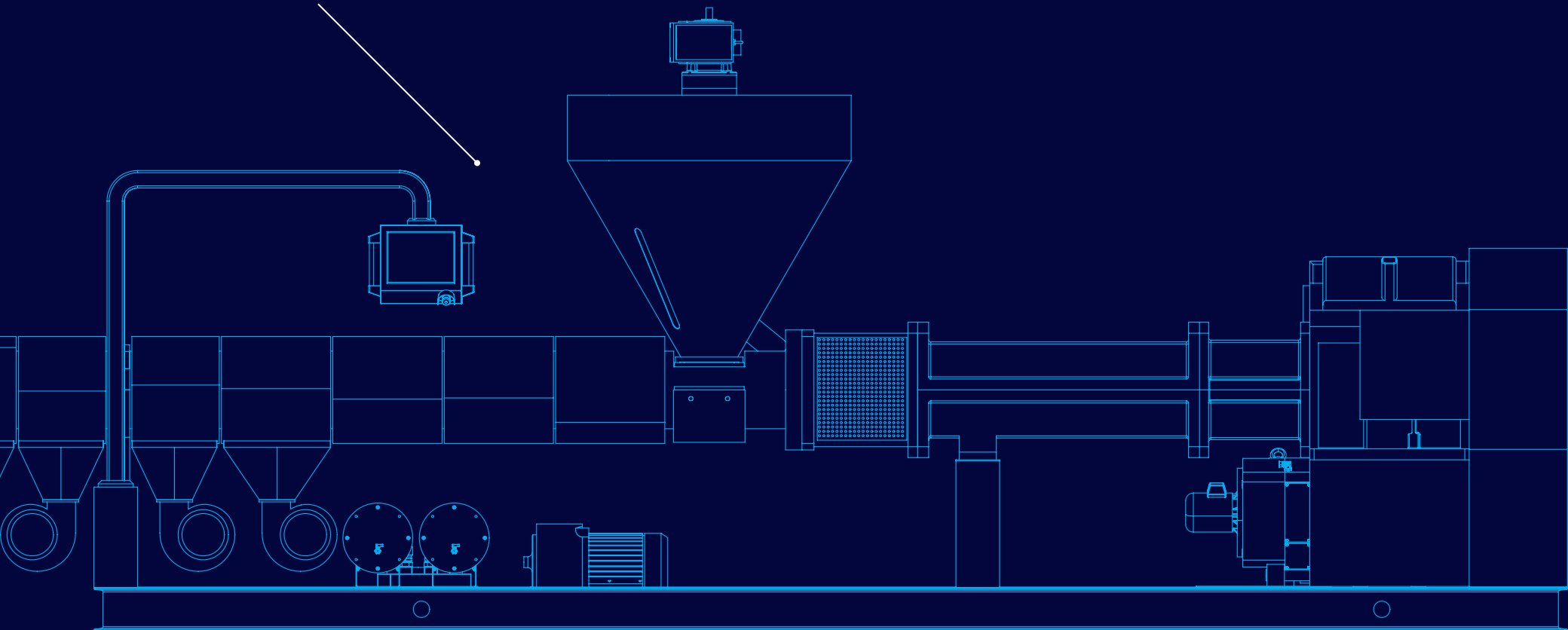

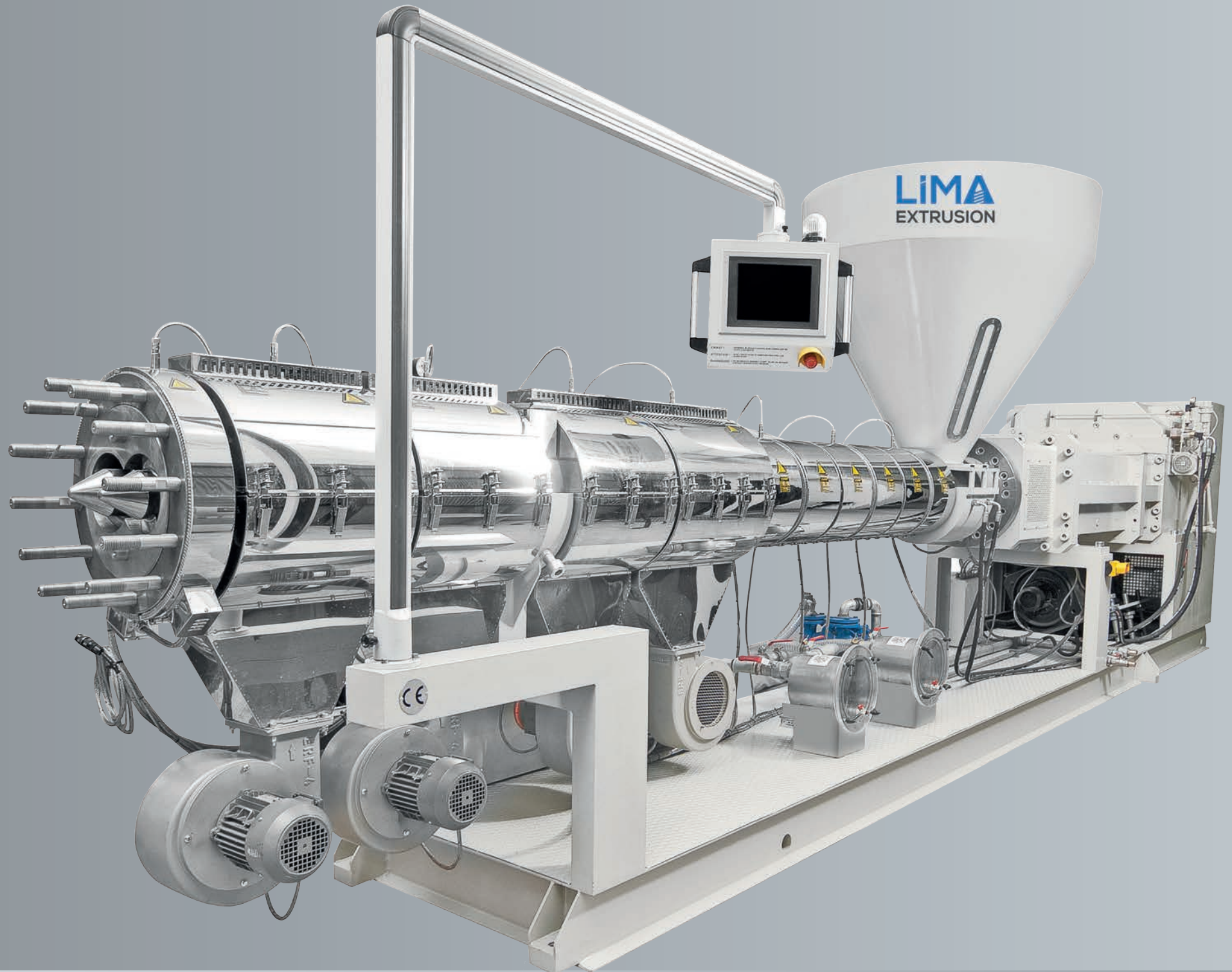

lima[®] extrusion

PARALLEL TWIN SCREW EXTRUDERS

	OUTPUT
P65.24	150-200 kg/h
P78.30	230-300 kg/h
P90.24	230-350 kg/h
P90.28	350-500 kg/h

	OUTPUT
P90.32	500-600 kg/h
P110.30	600-700 kg/h
P132.23	800-1.000 kg/h
P160.22	1.200-1.500 kg/h

* The given outputs depend on PVC, WPC/NFC material formulation.

All of our P-Series extruders have different lengths and drive motors to assure a proper plasticizing and output.

FEATURE	ОСОБЕННОСТИ	ÖZELLİKLER
Gearbox, screw and barrel set is made in Italy.	Коробка передач, винт и набор стволлов сделаны в Италии.	İtalyan redüktör, vida ve kovan seti.
High flexibility in raw material combinations.	высокая гибкость в плане применения различных комбинаций исходного сырья.	Hammadde formülasyonlarında yüksek esneklik
Different screw geometries for customer's special needs.	равномерная и гомогенная пластификация разнообразная геометрическая конфигурация.	Özel ihtiyaçlar için farklı vida ölçüleri.
AC motors offering optimum efficiency.	Двигатели переменного тока с оптимальным КПД.	Yüksek verimli AC motorlar.
Industrial PC / PLC	Промышленный ПК/ПЛК	Endüstriyel PC / PLC
Industry 4.0	Индустрия 4.0	Endüstri 4.0

Synchronized with the various components of the line.



lima[®] extrusion

HEAD WITH CUTTING UNIT

FEATURES	ОСОБЕННОСТИ	ÖZELLİKLER
Cutting capacity up to 1.500 kg/h	Производительность нарезания до 1500 кг/ч	1500 kg/s'e kadar kesim kapasitesi.
Die head equipped with cutting.	Экструзионная головка оснащена блоком нарезки.	Kesici üniteyle donatılmış kafa ünitesi.
Cutting speed adjustment by variator.	Регулировка скорости нарезки посредством вариатора.	Varyatör ile ayarlanabilir kesim hızı.
Blower for transferring pellets to cooling unit.	Точное распределение толщины стенки.	Soğutma ünitesine, Blower ile granül aktarımı.
Long lasting knives with special steel material.	Долговечные ножи из специальной стали.	Yüksek dayanımlı çelikten yapılmış bıçak.
Low maintenance cost.	Низкая стоимость обслуживания.	Düşük bakım maliyeti.



lima[®] extrusion

VIBRATION COOLING UNIT

FEATURES	ОСОБЕННОСТИ	ÖZELLİKLER
Cooling capacity up to 1500 kg/h	Производительность охлаждения до 1500 кг/ч	1500 kg/s'e varan soğutma kapasitesi.
Stainless steel cooling tunnel.	Охлаждающий туннель из нержавеющей стали.	Paslanmaz çelik soğutma tüneli.
Vibration system with cooling fan.	Вибрационная система с вентилятором охлаждения.	Soğutma fanlı titreşim sistemi.
Low maintenance cost.	Низкая стоимость обслуживания.	Düşük bakım maliyeti.

lima[®] extrusion AUXILIARY EQUIPMENTS

All lima[®] extrusion pelletizing lines can be equipped with various auxiliary equipments in order to meet our customer's requests and provide solution from a single source.





lima[®] extrusion **TECHNICAL SUPPORT**

We provide you with fast and reliable assistance whether on site or remote online services.

Our experts can analyze the malfunctions with remote access technology and fix them instantly.

AFTER SALES SERVICE

We support you throughout your machine's lifecycle with a strong focus on your specific needs.

In order to satisfy your wishes, we provide you a wide range of services including commissioning, inspection, maintenance and repair.

lima[®]
extrusion
a lider makina company

Lider Makina Sanayi ve Ticaret Limited Şirketi
Yenidođan, Ferhatpařa Caddesi Ozar Sanayi Sitesi
A Blok No:12A, Bayrampařa 34030 İstanbul, TR

T +90 212 544 5060
F +90 212 544 5063
info@limaextrusion.com

You can find further information at:
limaextrusion.com