

OTTOMAN MARINATION UNIT

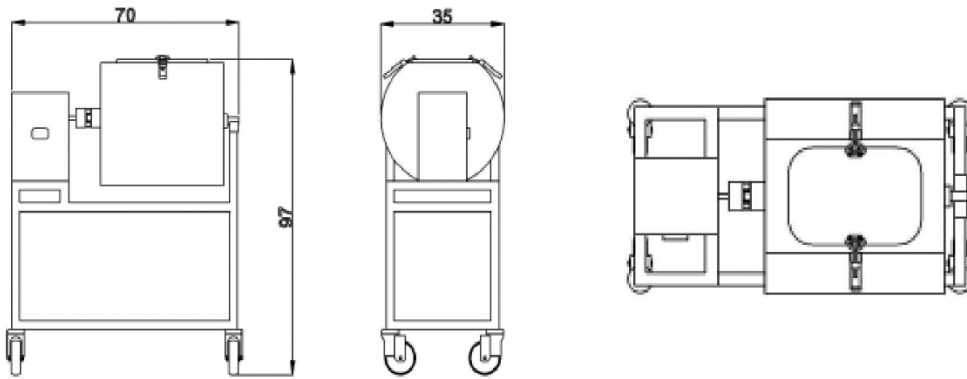

Ottoman Mutfak Marination unit helps marinate your chickens. It allows the sauces that you will use on your chickens to spread all over the chicken and penetrate the chicken.

The sauces made by using the Ottoman Mutfak Marination Unit help you increase the taste you offer to your customers.



Technical Specifications

- Stainless steel body
- With timer
- Mobile
- 1/1 GN chicken dumping area
- Easy cleaning

Volts	Phase	Hertz	Power	Timer	Wire	Amper
220 V	1	50	0,5 Kw	5-30 min.	3x2,5	6 A

Dimensions

Height: 97 cm (*height of platform*)
Width: 35 cm
Depth: 70 cm
Weight: 35 kg

Required clearances

Top: 5 cm
Sides: 5 cm
Back: 5 cm
Front: 5 cm

Capacity

25 lt.

Laboratory certifications



- APPROVED
- APPROVED AS NOTED
- RESUBMIT

AUTHORIZED SIGNATURE

DATE