

Drumpump P200/329-2/L

To be used for:

- 200 l drums

Consisting of:

- Pumpmotor with muffler
- Pressure regulator with manometer and safety valve
- Pumptube with piston and double seal type
- Ventilation with sample taking ball valve and manometer
- Follower plate with wiper ring
- Pneumatic cut-off valve for pump cut-off in case of empty drum
- Signal generator for alarm lamp connection
- Base plate with adjustable drum stopper for drum centering
- Pneumatic pump lift
- Ink hose 2 m long with high pressure ball valve
- Compressed air hose 1,5 m long

Accessories:

- Power supply
- Alarm flash light

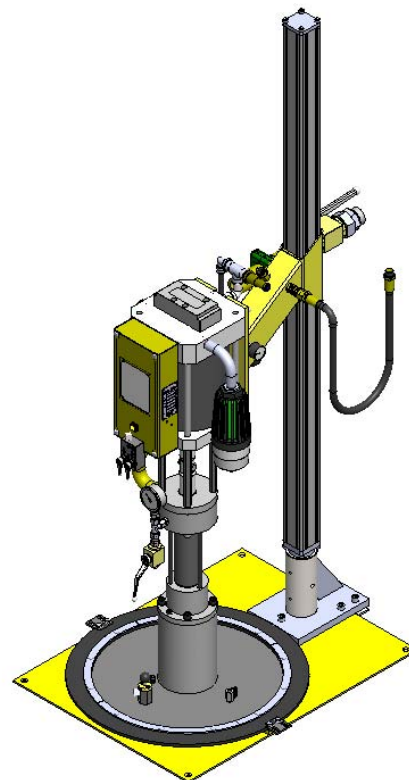

Technical data:

Height	mm	1830 2770	retracted elevated
Width	mm	620	Base plate
Depth	mm	810	Base plate
Diameter Pumpmotor	mm	200	
Pressure ratio	-	30 : 1	
Delivery rate /Cycle	cm ³	329	
Max. air pressure	bar	5	
Air consumption	NI	180	per kg fed ink at 5 bar
Ink hose connection (pressure side)	mm "	DN 40 G 1 ½	
Compressed air connection	mm "	DN 12 R ½"	
Noise emission	dB(A)	<80	
Net weight	kg	ca. 180 -	Inkl. hoses, ball valve and coupling

Subject to technical modifications