



Company Profile

Vivian Doo

Overseas sales & marketing Manager

418-54 Sangjiseok-gil, Paju-si, Gyeonggi-do, South Korea

Phone: +82+(0)31-9758312

Fax: +82+(0)31-9758316

Mobile: +82+(0)10-3039-5182

E-mail: bowondoo@gmail.com, doosanmc61@daum.net

Homepage: doosanmc.com



A blue line starts from the top-left corner and extends diagonally to the right, ending at a thick blue horizontal bar. From the right end of this bar, a thin blue horizontal line extends across the top of the page.

CHAPTER

01 Company Overview

COMPANY INTRODUCING

MAIN SUPPLIER



■ **Company Name:**

DOOSAN ELECTRONIC MACHINERY &
EQUIPMENT

■ **Representative director and president :**

JANGWHAN DOO

■ **Established :**

1986

■ **Location :**

418-54 Sangjiseok-gil, Paju-si, Gyeonggi-do,
South Korea

■ **BUSINESS FIELD:**

POUCH MAKING MACHINE, ZIPPER BAG,
SPOUT MACHINE, DIE CUT MACHINE
SLITTER AND ETC.

■ **MAIN PRODUCT:**

- 3 SIDE SEAL BAG MAKING MACHINE
- CENTER/ END SEAL BAG MAKING MACHINE
- STANDING POUCH & STANDING ZIPPER
POUCH MAKING MACHINE
- FLAT BOTTOM BAG MAKING MACHINE
- SLITTER AND ETC..

Organization

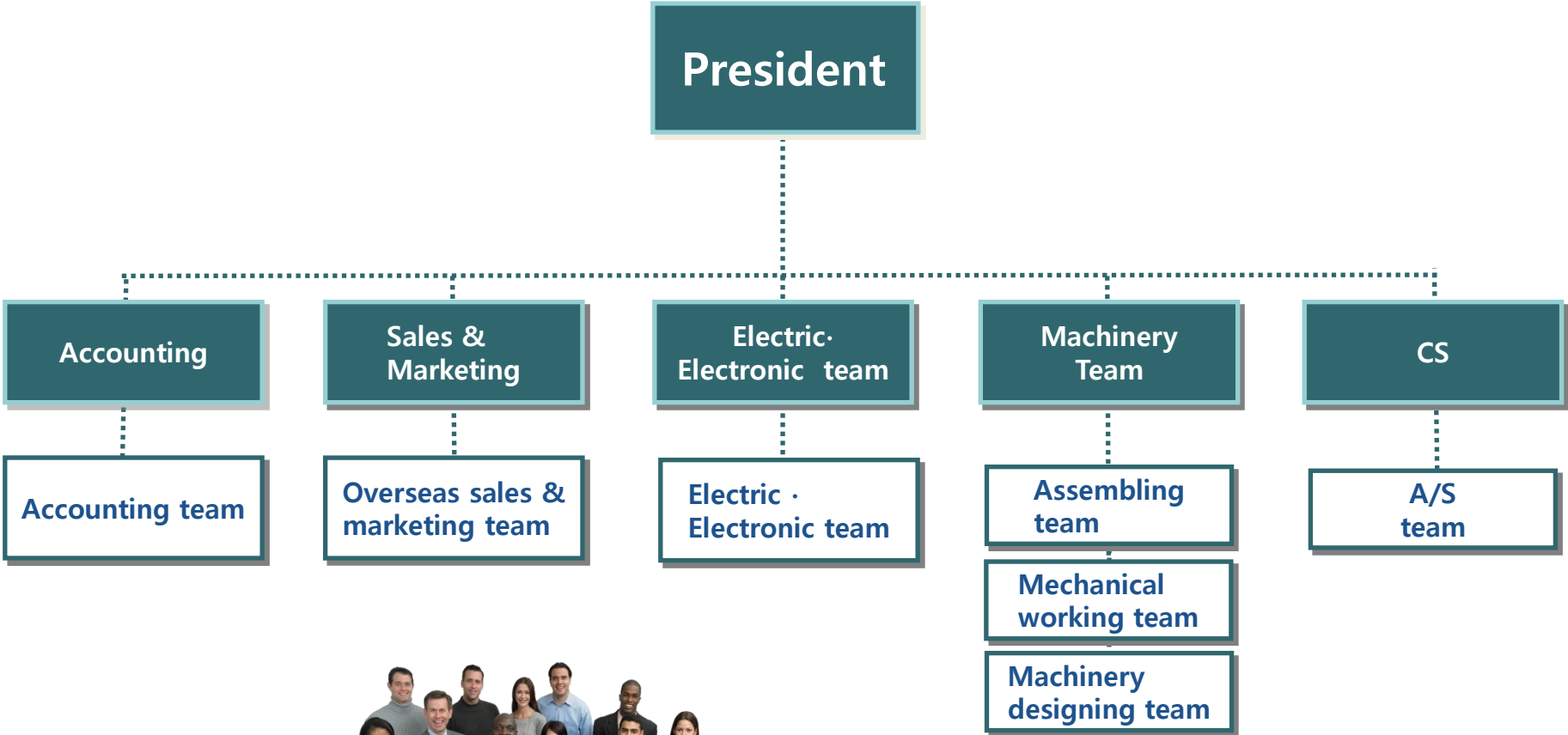

1986

- Founded Doosan electric

1998

- Company Name and industry changed to DOOSAN electronic machinery & equipment
- Developed DSM-600SS, DSM-600ST, DSM-350CSG, DSM-600SFZ
- Starting to export bag making machines to Poland & Egypt.

1999 ~ 2004

- Developed DSM-600SPZ, DSM-600ST4, DSM-600TQZMML
- Starting to export machines to Australia.
- Participating 2004 Germany K show & DRUPA Show (du:sseldorf)

2005~2011

- Starting to export machines to France and Vietnam.
- Participating annual KOREA PACK Exhibition, 2005-2011
- Factory reconstruction and relocation to Paju-si, Aug. 2011

2012~2014

- Developed DSM1200-BIB, DSM600-SB, DSM-600SD
- Participating Propack Asia 2013, 2014
- Awarded 2014 Small & medium enterprises management
- Achieving ISO 9001: 2008 Certificate
- Recognized R & D department by Koita

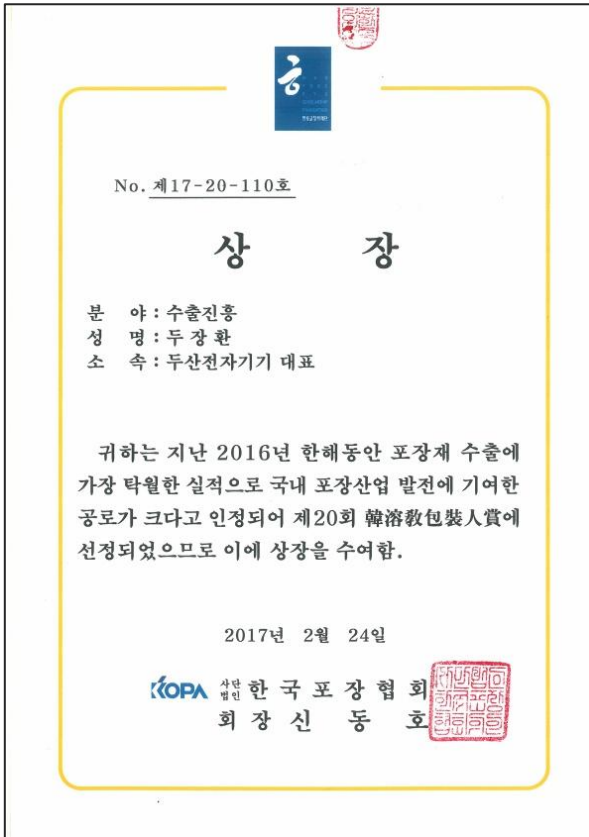

Export promotion

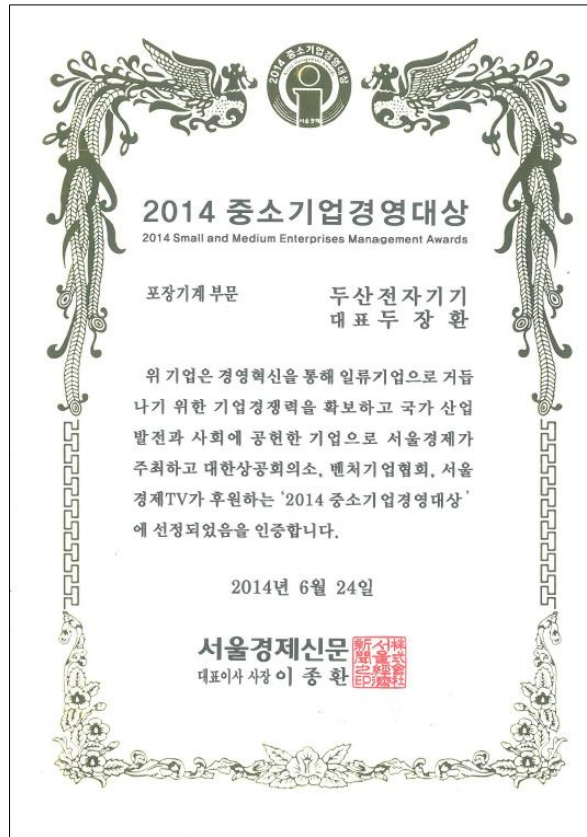

2014 Small & Medium Enterprises Management Awards



Recognized R & D department by Korean Industrial technology association

MAIN SUPPLIER

■ Current exporter Countries: Egypt, Poland, Germany, Iran, France, Australia, Vietnam, Thailand etc..

- * KSP CO., LTD (KOREA)
- * D&C CO. (KOREA)
- * HANYANG PACKAGE CO., LTD (KOREA)
- * SEOKWANG INDUSTRIAL CO., LTD (KOREA)
- * SEAL TECH CO., LTD (KOREA).
- * MIJIN COMPANY (KOREA)
- * YOUNGSHIN PLASTIC(KOREA)
- * REUTHER GMBH (GERMANY)
- * A & M PACKAGING CO., LTD(AUSTRILA)
- * REUTHER POLAND (POLAND)

2001 ~ 2003

1998 ~ 2000

- *MISUN INDUSTRIAL CO., LTD (KOREA)
- *DONGSHIN CHEMICAL CO., LTD(KOREA)
- *DS TECHNO CO. (KOREA)
- *KYUNG DONG INDUSTRIAL (KOREA)
- *HANYANG PACKAGE CO., LTD(KOREA)
- *L&K CO., LTD (KOREA)
- *AKEF PLASTIC & PACKAGE (EGYPT)

- * GASUNG PACKAGING(KOREA)
- * L&K CO., LTD (KOREA)
- * DAEWON INDUSTRIAL (KOREA)
- * SUNGIL PACKAGING (KOREA)
- * YOUNGSHIN PLASTIC (KOREA)
- * JOOSEUNG INDUSTRIAL (KOREA)
- * L&K CO., LTD (KOREA)
- * DAELIM INDUSTRIES (KOREA)
- * DONGYEON PACKAGING INDUSTRY (KOREA)
- * INTERPORE INDUSTRY CO., LTD (KOREA)
- ETC..

2006 ~ 2007

2004 ~ 2005

- * C.S.C (KOREA)
- * L&K CO., LTD (KOREA)
- * SAMMIN-CHEMICAL CO., LTD (KOREA)
- * SEAL TECH CO., LTD (KOREA)
- * YOUNGBO INDUSTRIE (KOREA)
- * KEOSUNG PACKAGE (KOREA)
- * SUNGIL PACKAGE (KOREA)
- * YOOSANG INDUSTRIAL CO., LTD (KOREA)
- * YOUNGSHIN PLASTIC CO. (KOREA)
- * ALCAN CO., LTD (FRANCE)
- * MARAL CO. (IRAN)
- ETC..

2008 ~ 2009

- * CHANGDUK PACKAGING(KOREA)
- * DONGYEON PACKAGING INDUSTRY (KOREA)
- * JUN-PACKAGING(KOREA)
- * SAEWON INDUSTRY (KOREA)
- * L&K CO., LTD (KOREA)
- * DAEYOUNG INDUSTRY CO., LTD (KOREA)
- * L&S INDUSTRY (KOREA)
- * SUNGIL PACKAGING (KOREA)
- * JOOSEUNG INDUSTRIAL (KOREA)
- ETC..

- * DAEWON INDUSTRY(KOREA)
- * SEAL TECH CO., LTD (KOREA)
- * HYUNDAI PACKAGING(KOREA)
- * L&K CO., LTD (KOREA)
- * BOOYOUNG INDUSTRY (KOREA)
- * JS PLASTIC PACKAGING (VIETNAM).
- * YOOSANG INDUSTRIAL CO., LTD (KOREA)
- * D&C CO. (KOREA)
- * DAELIM INDUSTRIES (KOREA)
- ETC..

2010 ~ 2011

2012~

- * YOUYOUNG INDUSTRIAL CO., LTD (KOREA)
- * ERE MATERIALS(KOREA)
- * HYUNDAI PACKAGING(KOREA)
- * SUNG IL INDUSTRIAL CO., LTD (KOREA)
- * GREEN PACKAGING (KOREA)
- * Thai Flexible(THAILAND)
- * Nippon Pack(THAILAND)
- * Olympia(UAE)
- * Shine woo color pack (KOREA)
- * LLC MGU (Russia)
- * IMMER DIGITAL (Ukraine)
- * TURAS PLAST (Russia)
- * Roll pack (Korea)
- ETC..



VISION

Global Number 1. Electronic machinery & equipment company

Long term goals

2020 Achieving 60% global market share in Pouch making machine field

1. 3-SIDE SEAL POUCH MAKING MACHINE SERIES

HIGH SPEED & PRESSURE 3 SIDE SEALED ZIPPER POUCH MAKING MACHINE (Model: DSM-600SPZHD)

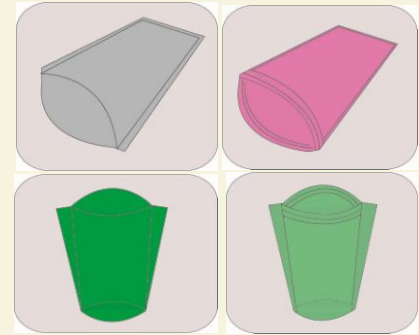
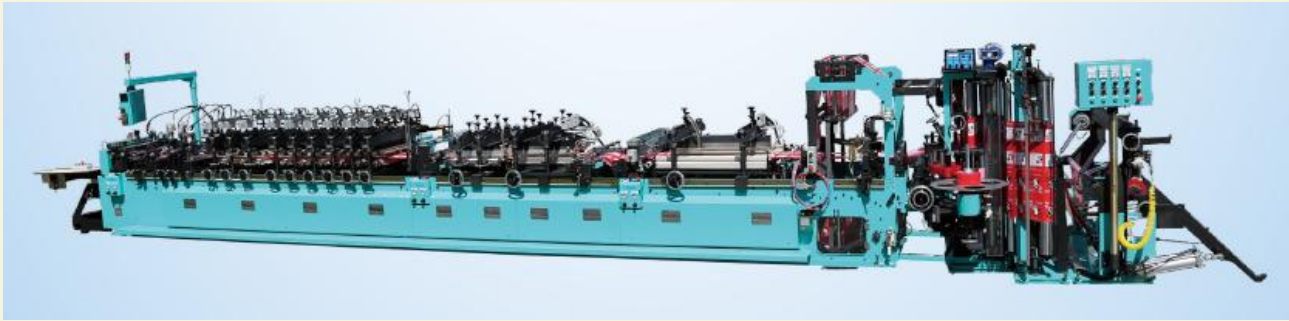

DSM600-SPZ

Machine Speed	200 shots / min *Production speed may be affected by the type of material and the cutting length.
Servo	6 servo
Pouch size range	Pouch Width : 60mm – 250mm Pouch Height : 120mm – 280mm for 2 –up Gusset depth : 20mm - 45mm Punching Dia. : 15mm (standard)
Size of main web	Width : 40mm – 1,240mm / Diameter : 800mm
Size of bottom web	Width : 60mm – 180mm / Diameter : 600mm

1. 3-SIDE SEAL POUCH MAKING MACHINE SERIES



ZIPPER POUCH MAKING MACHINE

(Model: DSM-600SPZ)

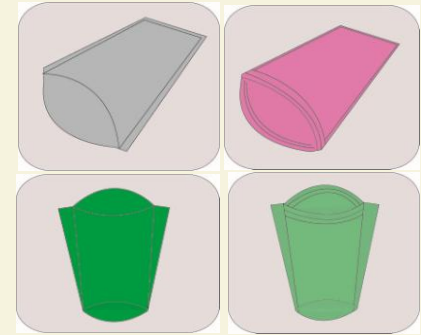

DSM600-SPZ

Production Speed (Zipper Bag) 30-110 shot/ min
(3 side seal) 30-160 shot/min
(Standing pouch) 30-120 shot/min

*Production speed may be affected by the type of material and the cutting length.

Pouch size range Pouch Width : 60mm – 250mm
Pouch Height : 120mm – 280mm for 2 –up
Gusset depth : 20mm - 45mm
Punching Dia. : 15mm (standard)

Size of main web Width : 40mm – 1,240mm / Diameter : 800mm

Size of bottom web Width : 60mm – 180mm / Diameter : 600mm

1. 3-SIDE SEAL POUCH MAKING MACHINE SERIES



ZIPPER BOTTOM FOLDED STAND UP POUCH AND TWO SIDE SEAL POUCH MAKING MACHINE

(Model: DSM-600SFZ)

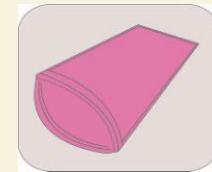
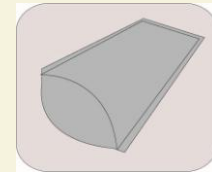

DSM600-SFZ

Production Speed	(Bottom folded stand up pouch) : 30-120 cycles/ min (Zipper bottom folded stand up pouch) : 30-120 cycles/min (Bottom folded two side seal pouch) : 40-100 cycles/min (Zipper bottom folded two side seal pouch) : 30-100 cycles/min *Production speed may be affected by the type of material and the cutting length.
------------------	--

Pouch size range	Bottom folded stand up pouch : (W) max. 500mm (L) max.600mm (1-lane) Zipper bottom folded stand up pouch : (W) max. 250mm (L) max. 600mm Bottom gusset depth : max. 60mm
------------------	--

Size of main web	Width : 400mm – 1,350mm / Diameter : 600mm
------------------	--

1. 3-SIDE SEAL POUCH MAKING MACHINE SERIES

STANDING POUCH/3-SIDE SEAL POUCH MAKING MACHINE (Model: DSM-600ST)

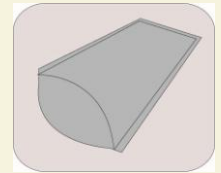

DSM600-ST

Production Speed	3 side seal: 30-160 Shot/ Min Standing pouch: 30-120 Shot/ Min *Production speed may be affected by the type of material and the cutting length.
Size of Raw material	Width: 400-1m250mm Diameter: 800mm
Size of Bottom web	Width: 60-180mm Diameter: 400mm

1. 3-SIDE SEAL POUCH MAKING MACHINE SERIES



HIGH SPEED 3 SIDE SEAL POUCH MAKING MACHINE (Model: DSM-600SD)

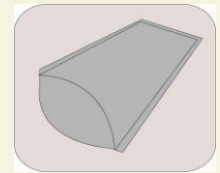

DSM600-SD

Machine Speed	Maximum number of shots : 240 CPM Maximum film speed : 45 m/min for film roll diameters 800mm to 600mm *Production speed may be affected by the type of material and the cutting length.
Size of Raw material	Max. parent-web width : 1,200mm Diameter: 800mm
Sealing width	Cross seal width: max. 80mm Longitudinal sealing width : max. 50mm *Wide heat sealed needed to sealing widths exceeded 50mm (Up to max. 80mm)

2. CENTER/ END PRESS SEAL POUCH MAKING MACHINE SERIES



CENTER PRESS SEAL POUCH MAKING MACHINE

(Model: DSM-350CSG)

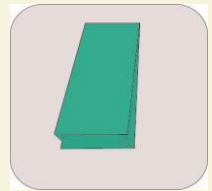
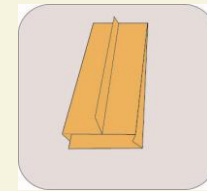
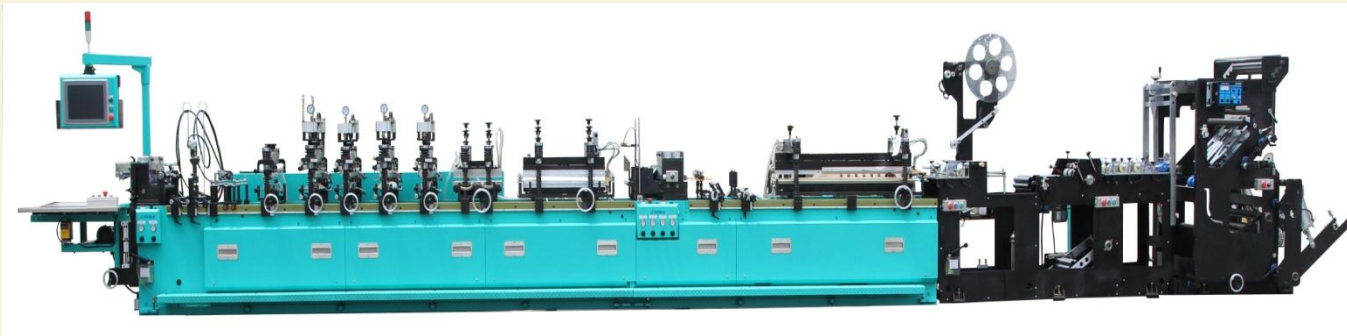

DSM-350CSG

Bag making speed 40mm – 180 shot/min

*Production speed may be affected by the type of material and the cutting length.

Pouch size range Pouch Width : 50mm – 400mm
Pouch Height : Up to 400mm
Bottom seal width : 5 to 50mm
Center seal width : 5 to 20mm
Gusset seal width : 5 to 7mm to be specified with the order
Gusset deep : 10 to 80mm

Web size Width : 120mm – 1,140mm / Diameter : 800mm with 75mm paper core

3. FLAT BOTTOM POUCH MAKING MACHINE



FLAT BOTTOM POUCH MAKING MACHINE

(Model: DSM600-SB)



DSM600-SB

Bag making speed

Max. 80 Shots/ min

*Production speed may be affected by the type of material and the cutting length.

Pouch size range

Min. (W) 100mm (L) 200mm

Max. (W) 330mm (L) 580mm

Web size

Width : max. 1200mm / Diameter : 800mm with 75mm paper core

Main control

Eight(8) servo system

Double cutting device

Min. 2mm

Included Accessories

Coreless trim-winder (2 sets), Zipper unit (2 sets)

Punch trash collector (2 sets), Hexagonal punching (2 sets)

Double cutting device

3. BAG IN BOX POUCH MAKING MACHINE



BAG IN BOX POUCH MAKING MACHINE

(Model: DSM1200-BIB)

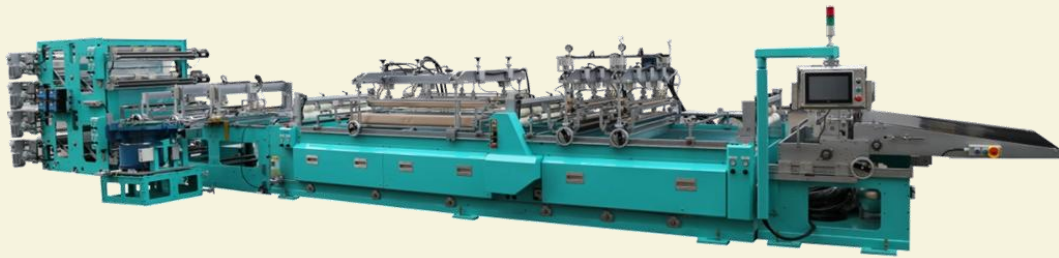

(Example picture)

4. RELATED MACHINES



SLITTER MACHINE

(Model:DS101-1300PCB)

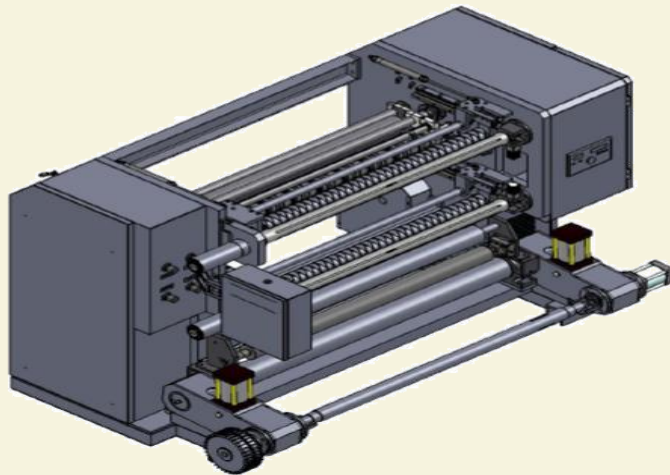

DS101-1300PCB

Machine speed	Max. 300m/min *Production speed may be affected by the type of material and the cutting length.
Web size	W : 200 – 1,300 mm Unwinder Dia : max. Ø800 Rewinder Dia : max. Ø 500
Slitting type	Razor or Shear knife cutting type



CORNER CUTTING MACHINE

(Model:DSMR8-CN)



DSMR8-CN

Machine size	665 x 675 x 1,470 (mm)
Weight	140kgs
Electricity	220V, 50Hz
Air	2Kg/cm ² G
	<ul style="list-style-type: none">• Power On/ Off• Cylinder Auto/ Manual Mode• Knife sensor Auto/ Manual Mode

4. RELATED MACHINES

SPOUT MACHINE (Model:DSM300-ASI)



(Example picture)

THOMSON DIE CUTTING MACHINE (Model:DSM600-TS)

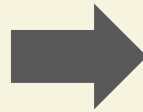

(Example picture)

4. RELATED MACHINES

 **TRIM WINDER**
(Model:DSM-TR400)



DSM-TR400

Power	1-phase, AC 220V, 60Hz
-------	------------------------

Winding Speed	0~35mm / min
---------------	--------------

Winding Package Diameter	390mm
--------------------------	-------

Winding package width	450mm
-----------------------	-------

A blue line starts from the top-left corner and extends diagonally to the right, ending at a solid blue horizontal bar.

CHAPTER

03 CORE COMPETENCE

Advanced Technologies

Competitive in the world

DOOSAN electronic machinery & equipments has been inventing high-tech computer system controlled machines to keep pace with the high technology era. DOOSAN is committed to providing continual development and innovation in its field.

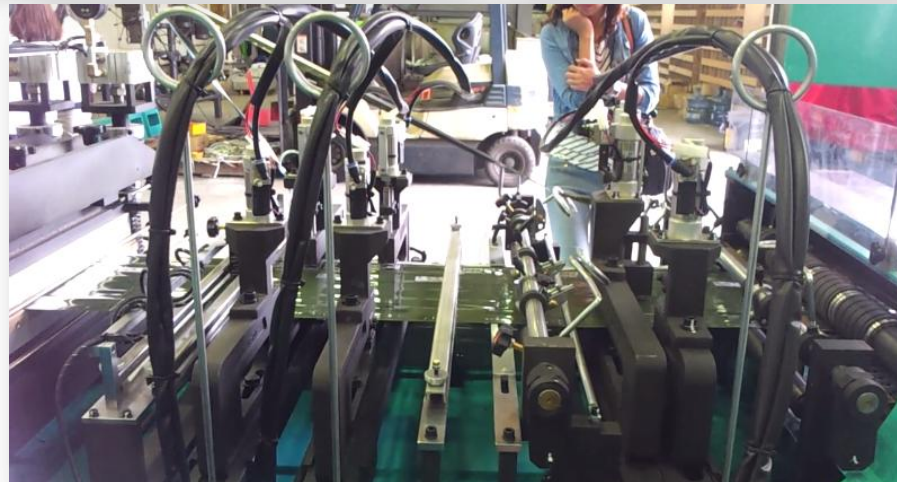

DOOSAN is focused to make machines which are harmonized with Windows program. To produce the best products, Operator needs to operate machine easier than before, and unnecessary time and elements need to be removed. Windows program and touch panel are making the best environment for operator who wants make the best products.

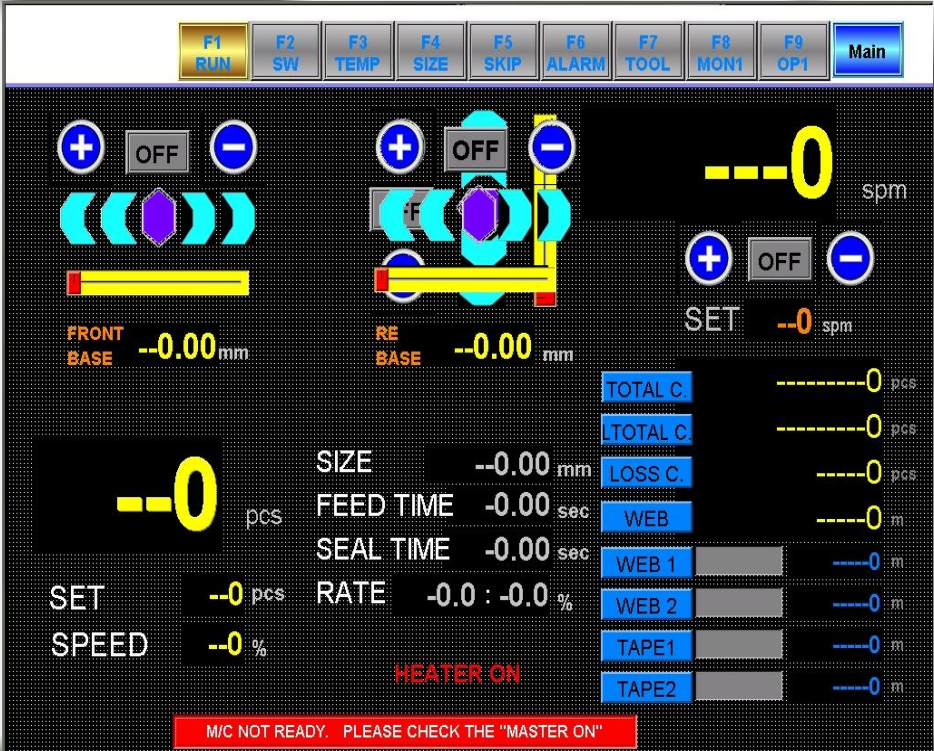

Our Current exporter Countries are Egypt, Poland, Germany, Iran, France, Australia, Vietnam, Thailand and etc..



Test running in German company in 2005



Thailand Company 'N' employees visited to DOOSAN in 2013

We had been participating in a lot of overseas machinery exhibitions.



K-show in 2004



Propack Asia in 2013