

YAMAN² SERİSİ / YAMAN² SERIES

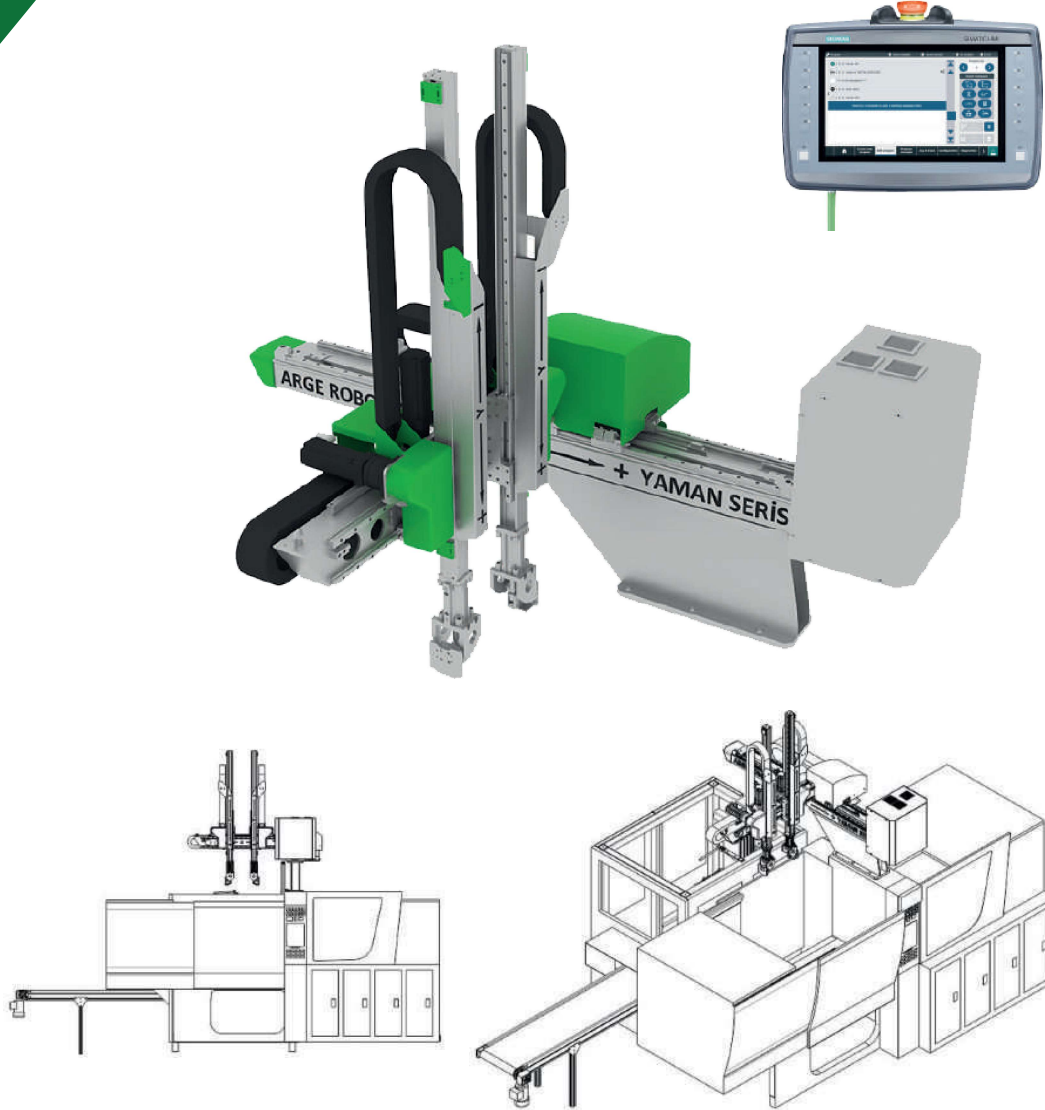

Genel Özellikler;

- Birbirinden bağımsız hareket eden iki ayrı kol
- Kısa Çevrim süresi
- Min. Çevrim süresi 5 sn. olan kalıplar için optimum çözüm

General Features;

- *Two separate arms that move independently*
- *Short Cycle Time*
Optimal solution for the minimum cycle time 5 sec. molds

| Model | I.M.M TON | Crosswise (X-axis) | | Vertical (Y-axis) | | Traverse | | Max.power consumption | Max.payload | Controller | Power Source | Driving Method |
|---------|-----------|--------------------|-------|-------------------|-----------------------|-------------|-------|-----------------------|-------------|---------------------|--------------------|---------------------|
| | | Stroke | Speed | Stroke | Speed | Stroke | Speed | | | | | |
| YAMAN 2 | 150-400 | 800 | 2m/sn | 1000 | Non Telescopic: 2m/sn | 1900 (2500) | 2m/sn | 3 KW | 8+8 kg | Siemens Mobil Panel | AC 380 V, 50/60 Hz | (All axes) AC Servo |