

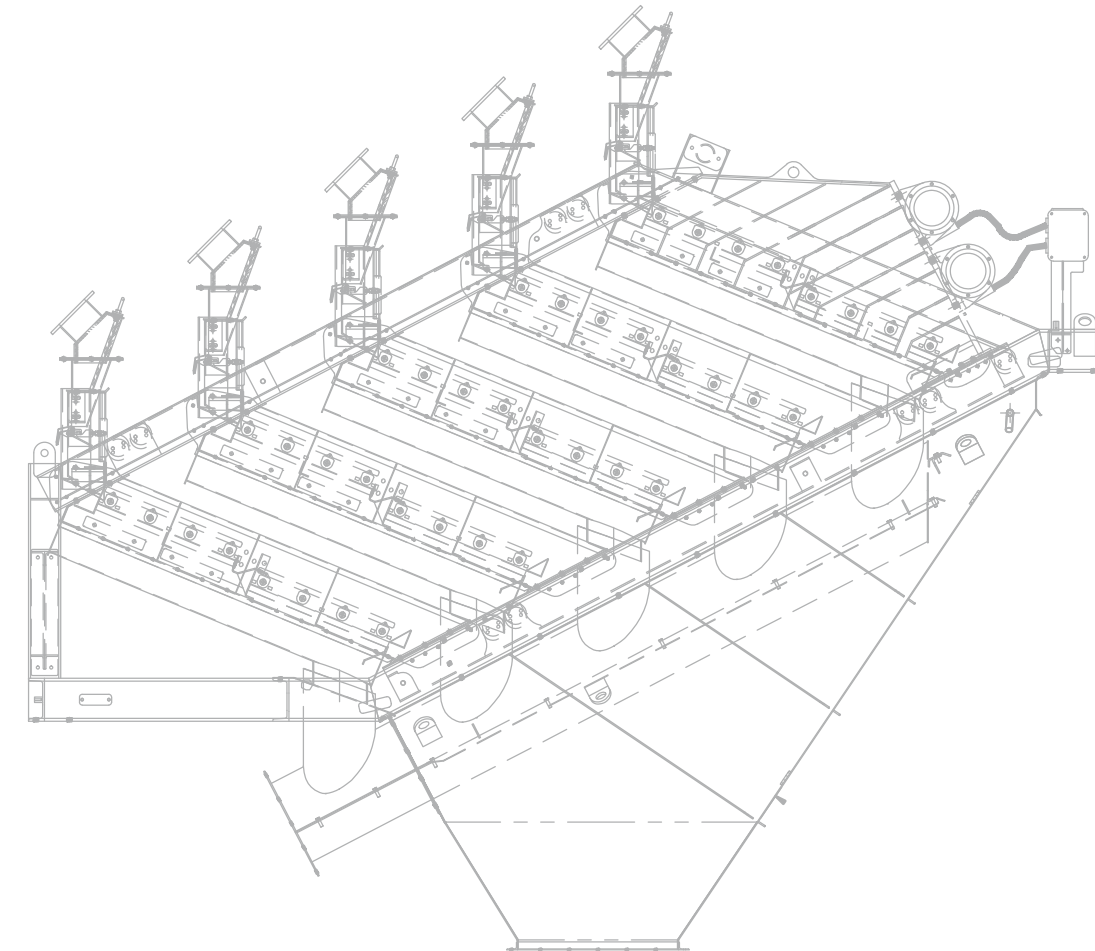

**GLOBAL FAMILY.
PIONEERING TECHNOLOGY.®**

Since inception, Derrick® has expanded its product portfolio to serve a variety of challenging markets within the Mining & Industrial, Oil & Gas Drilling, and Civil Construction industries.

Derrick remains committed to providing the latest advancements in fine-separation technology that evolve alongside industry best practices and market developments.

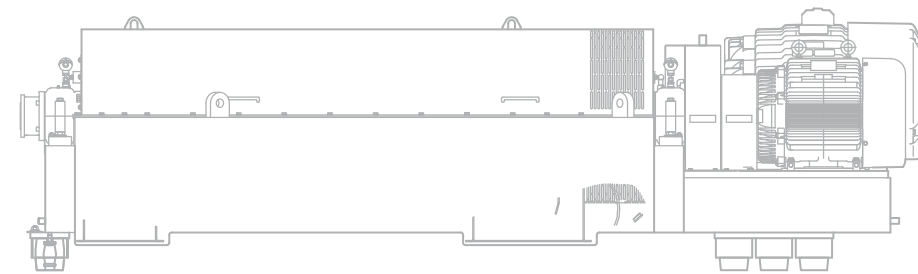
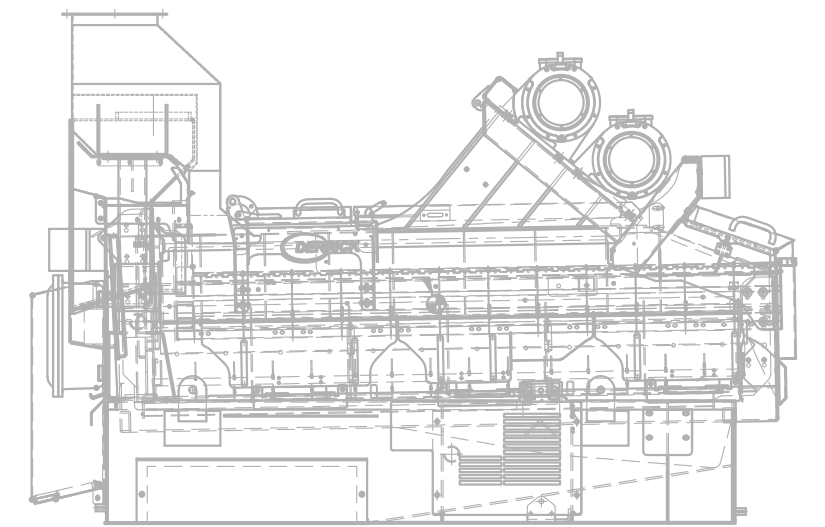
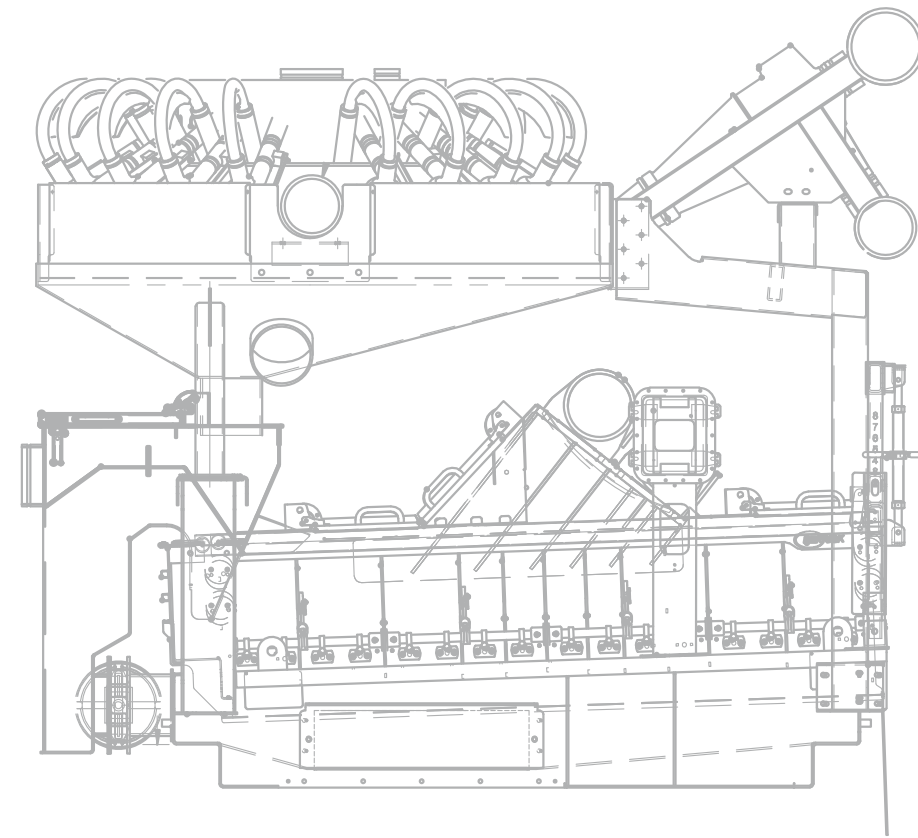

LETTER FROM THE FAMILY

Founded by H. William Derrick Jr. in 1951, Derrick Corporation was created to solve some of the most challenging mechanical separation needs of the Mining Industry. At the heart of our present-day offering resides the Integrated Vibratory Motor which was invented by our founder and gave life to an entire line of innovative separation technology. To this day, our pioneering spirit pulses through the organization and inspires development of our leading-edge solutions.

Over the years, we have experienced exponential growth, expanding from our Mining roots to Oil & Gas Drilling, Civil Construction, Industrial, and other challenging industries worldwide. Our robust installed base and expansive network of thousands of cohesive individuals are located across the globe.

Our success is fully dependent on people. Priority one is to serve our global families; our tenured employees, multi-national partners, and surrounding communities. Our unique, close-knit culture and shared, long-term outlook is not only paramount to our success, but to the success of all integral stakeholders.

We thank you for expressing interest in our organization and look forward to being of service to you in the future.

Sincerely,
The Derrick Family



H. William Derrick Jr. (1917-1992)



Bradley Derrick
President/COO

Mitchell Derrick
CEO

James Derrick
Co-Chairman of the Board

William Derrick
Co-Chairman of the Board

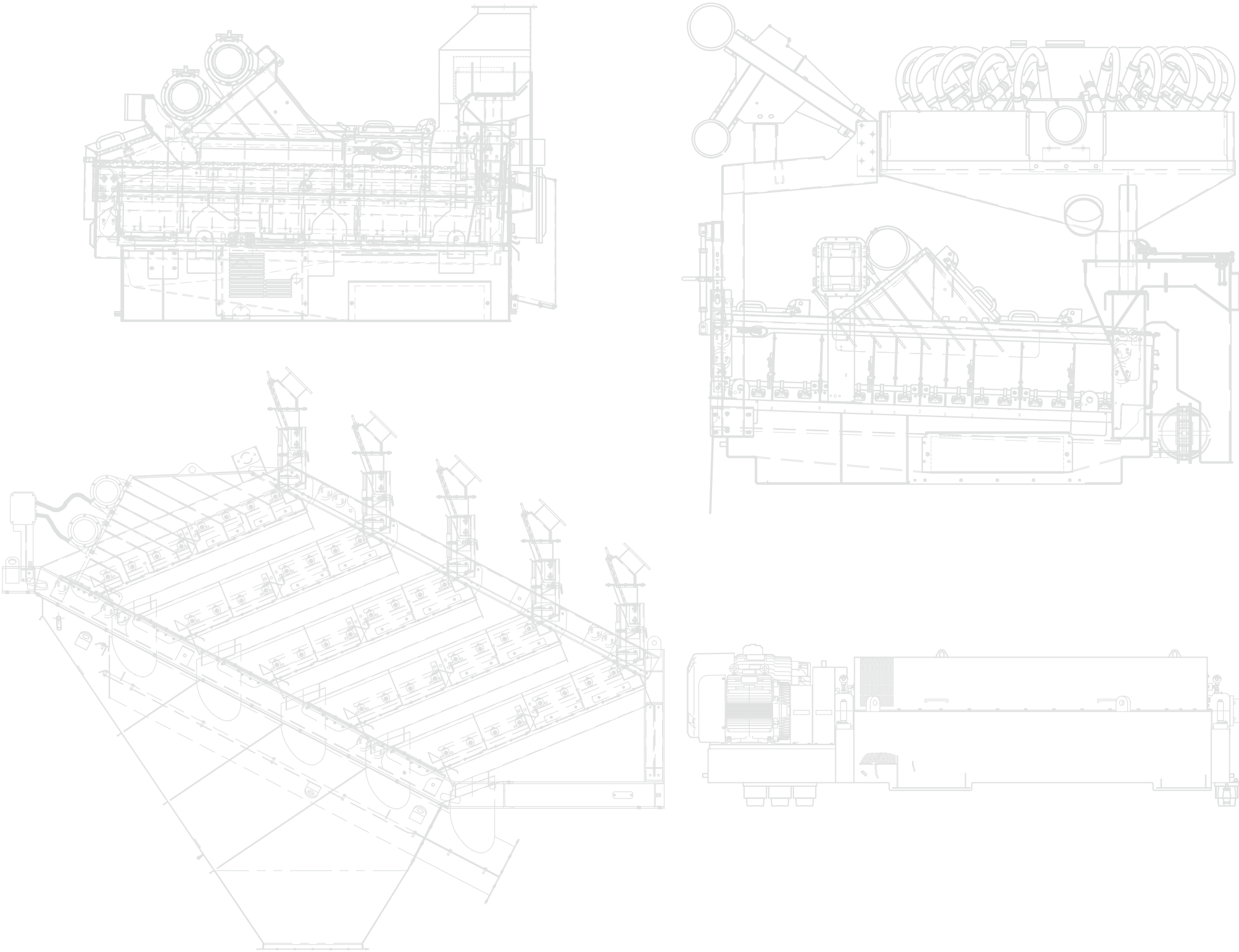

GLOBAL FAMILY[®]

The Derrick Family

Derrick is a community which consists of co-workers, distributors, sales representatives, and customers. Our universal presence is comprised of thousands of individuals in countries around the globe. As our business continues to expand, we maintain the tight-knit corporate culture established by our founder.



Community Enrichment

We see our surrounding communities as an extension of our family, and we share a collective interest in giving back. This is exemplified by our avid support of industry associations and numerous charitable organizations.



Global Sustainability

We support the recovery of natural resources in the most energy-efficient manner, placing vital importance on waste reduction and energy conservation. Our objective to increase our clients' operational performance within a smaller environmental footprint is evident throughout our offering.



Award-Winning Service

We understand the importance of supporting our family. Our dedicated service team provides unparalleled global support. Numerous industry awards substantiate this heightened commitment to meeting our customers' evolving needs.





Safety First

Safety is the utmost priority at Derrick. We train all employees in the latest Health, Safety, and Environmental (HSE) practices. Our facilities are held to the highest standards of cleanliness and organization to ensure the safety and well-being of all our family members.

PIONEERING TECHNOLOGY®

Continuous Innovation

Our pioneering spirit is best demonstrated by our research and development team's long-term commitment to continuous innovation. This mindset dates back to our founder's invention of the first Integrated Vibratory Motor and Sandwich Screen® Technology. Our quest to perpetually reinvent ourselves is exemplified by our ever-growing portfolio of U.S. and foreign patents.

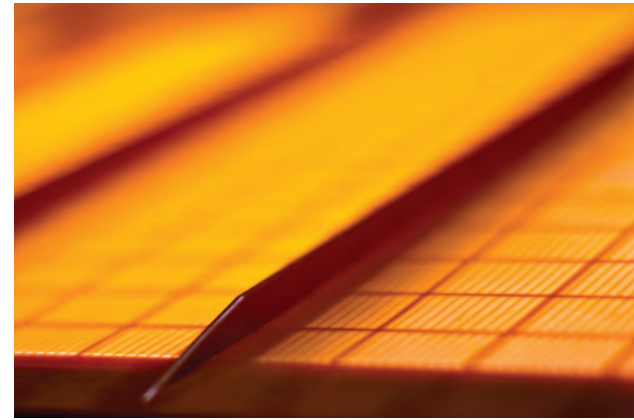

Leading-Edge Solutions

Our customers partner with us to overcome their most difficult fine-separation challenges. Design and Applications Engineers combine their mechanical and industry knowledge with our innovative Separation Technology to provide customers with state-of-the-art solutions to meet their ever-changing needs.



World-Class Technologists

From field-trained personnel to advanced-degree engineers, our diverse development team collaborates to build technologically superior solutions. Whether offshore or onshore, in a mill or on a rig - they represent the most knowledgeable world-class separation technologists in the industry.

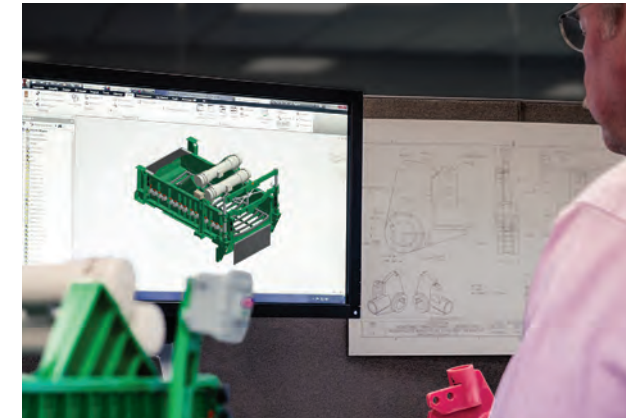

Quality Commitment

Our vertically integrated approach allows for the complete control of all aspects of product design and manufacturing. This comprehensive process ensures product dependability and enables us to offer long-lasting products which require minimal maintenance.



WE ARE DERRICK

The impassioned members of the Derrick team share a unified interest in designing and building innovative products for the markets we serve. As a family-owned and operated company, Derrick embraces its employment of numerous multigenerational families. We are proud of the fact that a substantial portion of our team has been with us for over two decades. This group's loyalty is honored and new members are welcomed annually to The Derrick Legacy Club* (featured below).



The Derrick Legacy Club
160+ employees
Combined tenure 4,700+ years

**Not all members pictured here*



We are a **Global Family**® focused on **Pioneering Technology**®.



We are a **Global Family**® focused on **Pioneering Technology**®.

Derrick Corporation
590 Duke Road
Buffalo, New York 14225 U.S.A.

Office: (716) 683-9010
Fax: (716) 683-4991

Derrick Corporation
15630 Export Plaza Drive
Houston, Texas 77032 U.S.A.

Office: (281) 590-3003
Toll Free: (866) DERRICK
Fax: (281) 590-6187

Email: info@derrick.com
Web: www.Derrick.com